

---

# ***INSTRUCTION MANUAL***

***15ppm Bilge Alarm***

***Type OMD-2005***

**DECKMA HAMBURG GmbH**

Kieler Straße 316, D-22525 Hamburg - Germany  
Tel.: +49 (0) 40 54 88 76-0, Fax: +49 (0) 40 54 88 76-10  
Internet: [www.deckma.com](http://www.deckma.com) eMail: [post@deckma.com](mailto:post@deckma.com)

---

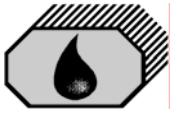

## **IMPORTANT NOTICE**

### **Replacement components for 15ppm Bilge Alarms.**

#### **General**

All monitors in our range are inspected and tested to the related I.M.O. requirements at our factories prior to delivery.

In normal use the units should operate correctly and without fault over a long period of time requiring only small amounts of maintenance to be carried out as outlined in the instruction manuals.

#### **Service Exchange Units**

In the event of a monitor malfunction due to electrical or electronic component failure it is our recommendation that a service exchange unit be ordered.

The defective instrument should be returned to our works within 30 days of supplying the service exchange unit, then only the repair charge is payable. Otherwise the whole cost of a service exchange unit becomes payable.

This procedure is by far the easiest and most cost effective way of ensuring the monitor on board conforms to I.M.O. resolution MEPC.107 (49).

#### **Remark:**

*According to MEPC.107(49) § 4.2.11 the unit has to be checked at IOPP Certificate renewal survey by the manufacturer or persons authorized by the manufacturer. Alternatively the unit may be replaced by a calibrated 15 ppm Bilge Alarm. The OMD-2005 is designed in that way, that only the measuring cell needs to be changed, as this unit carry the calibration onboard. The Calibration Certificate with the date of the last calibration check should be retained onboard for inspection purposes.*

If for some reasons the computer unit needs to be changed, it has to make sure, that the memory card will remain on board for at least 18 month. The new computer unit will carry its own memory card. The old card can be insert into the new unit only for reading. Writing is only possible with the card delivered with the new computer unit. For details see section 13.1.

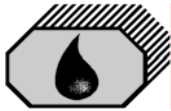

## CONTENTS

| SECTION | TITLE                               | PAGE |
|---------|-------------------------------------|------|
| 1.0     | Introduction                        | 4    |
| 2.0     | Important Notes                     | 4    |
| 3.0     | Principle of Operation              | 4    |
| 3.1     | Measuring Principle                 | 4    |
| 3.2     | Features                            | 5    |
| 3.3     | Adjustment                          | 5    |
| 3.4     | Displays and Alarms                 | 5    |
| 4.0     | Specification                       | 7    |
| 5.0     | Construction                        | 8    |
| 6.0     | Installation                        | 9    |
| 7.0     | Piping                              | 10   |
| 8.0     | Wiring                              | 11   |
| 8.1     | Typical Control System              | 13   |
| 9.0     | Power Supply                        | 13   |
| 10.0    | Commissioning                       | 13   |
| 10.1    | Electrical                          | 13   |
| 10.2    | Piping                              | 13   |
| 10.3    | Functional Tests                    | 14   |
| 10.4    | Programming Mode                    | 15   |
| 11.0    | Operating Instructions              | 17   |
| 11.1    | Operator Notes                      | 18   |
| 12.0    | Operator Maintenance                | 18   |
| 12.1    | Manual Cell Clean Unit              | 19   |
| 13.0    | Fault Finding                       | 20   |
| 13.1    | Memory Card                         | 21   |
| 14.0    | Calibration                         | 22   |
| 14.1    | Calibration and Repeatability Check | 22   |
| 15.0    | Spare Parts                         | 23   |
| 15.1    | Recommended On Board Spares         | 23   |
| 16.0    | Remarks                             | 24   |

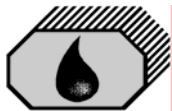

## 1.0 INTRODUCTION

The OMD-2005 Bilge Alarm Unit has been designed specifically for use in conjunction with 15 ppm oil-water separator units and has a specification and performance which exceeds the requirements of the International Maritime Organization specifications for 15ppm Bilge Alarms contained in Resolution MEPC. 107 (49).

The unit is supplied with 2 works-adjusted alarms at 15 ppm. Other set points (10 ppm or 5 ppm) are possible and can be adjusted on site at any time by using the buttons at the front panel.

If an alarm set point is exceeded, the alarms are visible at the front panel and the appropriate relays are switched. In case of malfunction the System LED at the front panel will change from blinking green to permanent red and the appropriate relay will switch the contacts.

For the data logging function the unit requires an status input from the separator and a feedback signal from the valve position limit switch. (See Fig. 1, Pos.6)

Furthermore a 0(4) - 20 mA (equal to 0 - 30 ppm) signal output is available for driving a recorder or external meter.

## 2.0 IMPORTANT NOTES

- a) This equipment must be installed and operated in strict accordance with the instructions contained in this manual. Failure to do so will impair the protection provided.
- b) Installation and servicing must be undertaken by a competent and suitable skilled person.
- c) The equipment must be connected to the ground according relevant requirements.
- d) The unit must be isolated from the electrical supply before any maintenance of the equipment is attempted.
- e) All National or local codes of practice or regulations must be observed and, where applicable, are deemed to take precedence over any directive or information contained in this manual.
- f) In case of freezing conditions the measuring cell should be emptied complete.

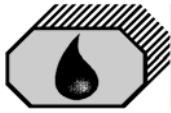

## 3.0 PRINCIPLE OF OPERATION

### 3.1 Measuring Principle

An optical sensor array measure a combination of light scattered and absorbed by oil droplets in the sample stream. The sensor signals are then processed by a microprocessor to produce linearised output.

If an alarm (works set point 15 ppm) occurs, the two oil alarm relays are activated after the adjusted time delay.

The microprocessor continuously monitors the condition of the sensor components and associated electronics to ensure that calibration accuracy is maintained over time and extremes of environmental conditions.

### 3.2 Features

- Robust construction
- Automatic voltage selection
- Solid suppression capability
- Low maintenance
- Easy installation
- Constant readiness
- Low spare part stock holding
- Watertight Housing
- Works adjustment
- Easy settings via menu

### 3.3 Adjustment

The unit is delivered with a works calibration according the IMO-requirements. The alarm points are set to 15 ppm.

The "Zero" point is also works calibrated and can be re-adjusted on site by using the programming mode and clean water. See Section 10.4 "Service-Offset". A calibration is not permitted. This has to be done according IMO Regulations by the manufacturer or persons authorized by the manufacturer.

### 3.4 Displays and Alarms

In the unit are two independent oil alarm circuits available. Both can be set separately from 1 to 15 ppm. From the manufacturing both alarms are set to 15 ppm (according IMO). The set points can be changed according to the requirements on site, for example to 10 ppm or 5 ppm. An alarm point setting above 15 ppm is not possible. The adjustment can be done in the programming mode as described in Section 10.4.

In this mode also the individual adjustment of the time delays for the alarms and the possible changing between 0 - 20 mA or 4 - 20 mA output can be done.

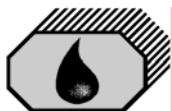

Both alarm circuits are also related to an alarm LED on the front panel.

In case of malfunction the “System” LED will indicate any type of internal fault of the unit. This LED is flashing green in normal conditions and is red in alarm conditions. Also this alarm is related to an relay output.

Additional to the alarm LED's each alarm circuit is equipped with a relay with potential free alarm contacts. These contacts can be used for external processing of the signal or for control of further functions.

If a malfunction or failure of the power supply occurs, all 3 relays will switch to alarm condition.

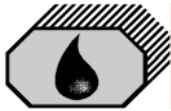

## 4.0 SPECIFICATION OMD-2005

|  |   |
|--|---|
| Range:   | 0 – 30 ppm, Trend up to 50 ppm  |
| Accuracy   | According IMO MEPC. 107(49)   |
| Linearity  | Up to 30 ppm better than $\pm 2\%$  |
| Display  | Green Graphic Display   |
| Power Supply:  | 24 V – 240 V AC or DC<br>Automatic Voltage Selection                        |
| Consumption:   | < 15 VA   |
| Alarm Points 1 + 2:                                    | Adjustable between 1 - 15 ppm<br>(Works adjustment 15 ppm)                  |
| Alarm 1 Operating Delay:<br>(for annunciation purpose) | Adjustable between 1 – 540 sec.<br>(Works adjustment 2 sec)                 |
| Alarm 2 Operating Delay:<br>(for control purposes)     | Adjustable between 1 – 10 sec.<br>(Works adjustment 10 sec)                 |
| System Fault Alarm:                                    | Red LED   |
| Alarm Contact Rating:                                  | Potential free 1 pole change over<br>contacts, 3 A / 240 V                  |
| Alarm Indication:                                      | Red LED's   |
| Output Signal:   | 0 – 20 mA or 4 – 20 mA for 0-30 ppm<br>reversible, ext. Load < 150 $\Omega$ |
| Sample Water Pressure:                                 | 0,1 – 10 bar  |
| Sample Flow:   | Approx. 0,1 - 4 l/min depend. to pressure                                   |
| Ambient Temperature:                                   | + 1 to + 55° C  |
| Sample Water Temperature:                              | + 1 to + 65° C  |
| Roll:  | Up to 45°   |
| Size (over all):                                       | 360 mm W x 240 mm H x 100 mm D  |
| Degree of Protection:                                  | IP 65   |
| Weight:  | 7,3 kg  |
| Pipe Connections:                                      | R ¼" Female   |

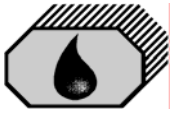

## 5.0 CONSTRUCTION

There are 3 main parts which contained in an OMD-2005:

The computer unit is mounted into an epoxy powder painted steel housing to protect the electronics of the display PCB with the data logger and the main board PCB with the terminals for external connections.

The measuring cell is built out of an anodized all-aluminium body with inlet and outlet block in stainless steel. This rugged cell contains the optical electronic and correspond with the computer unit via a plugged data cable.

The valve assembly contains a special handle to sense the position of the valve. This assembly is connected to the measuring cell by an easy to handle fitting to enable the exchange of the cell for frequently adjustment according the IMO requirements.

All components are mounted to a stainless steel mounting plate for easy wall or bulkhead installation. It is also possible to split the computer unit from the measuring cell if the available space is not sufficient. For this version divided mounting plates are available.

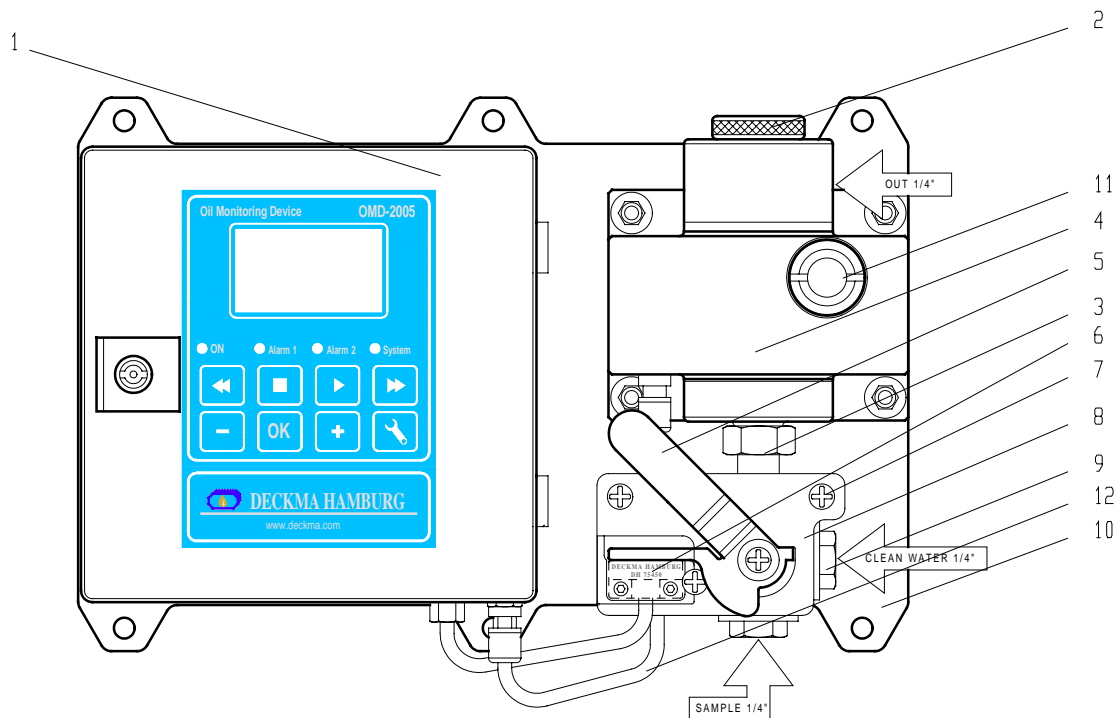

|   |                |   |              |    |                     |
|---|----------------|---|--------------|----|---------------------|
| 1 | Computer Unit  | 5 | Handle       | 9  | 3/2 Way Valve       |
| 2 | Head Screw     | 6 | Limit Switch | 10 | Mounting Plate      |
| 3 | Fitting        | 7 | Spacer       | 11 | Desiccator          |
| 4 | Measuring Cell | 8 | Valve Plate  | 12 | Communication Cable |

Fig. 1



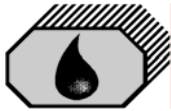

## 6.0 INSTALLATION (Refer to Fig. 2 and Fig. 3)

See Section 2 for important notes concerning installation.

The OMD-2005 Monitor should be located as close as possible to the oily water separator to minimize response delays. According MEPC.107(49) the layout of the installation should be arranged so that the overall response time (including the response time of the 15 ppm Bilge Alarm) between an effluent discharge from the 15 ppm Bilge Separator exceeding 15 ppm, and the operation of the Automatic Stopping Device preventing overboard discharge, should be as short as possible and in any case not more than 20 s.

Mount the OMD-2005 Monitor by means of 6 x M8 screws on to a rigid vertical surface and preferably with the display panel of the monitor at eye level. For service and maintenance sufficient space to all sides should be available.

Care must be taken at mounting of the pipes connections to avoid any torsion of the housing and damage of the instrument.

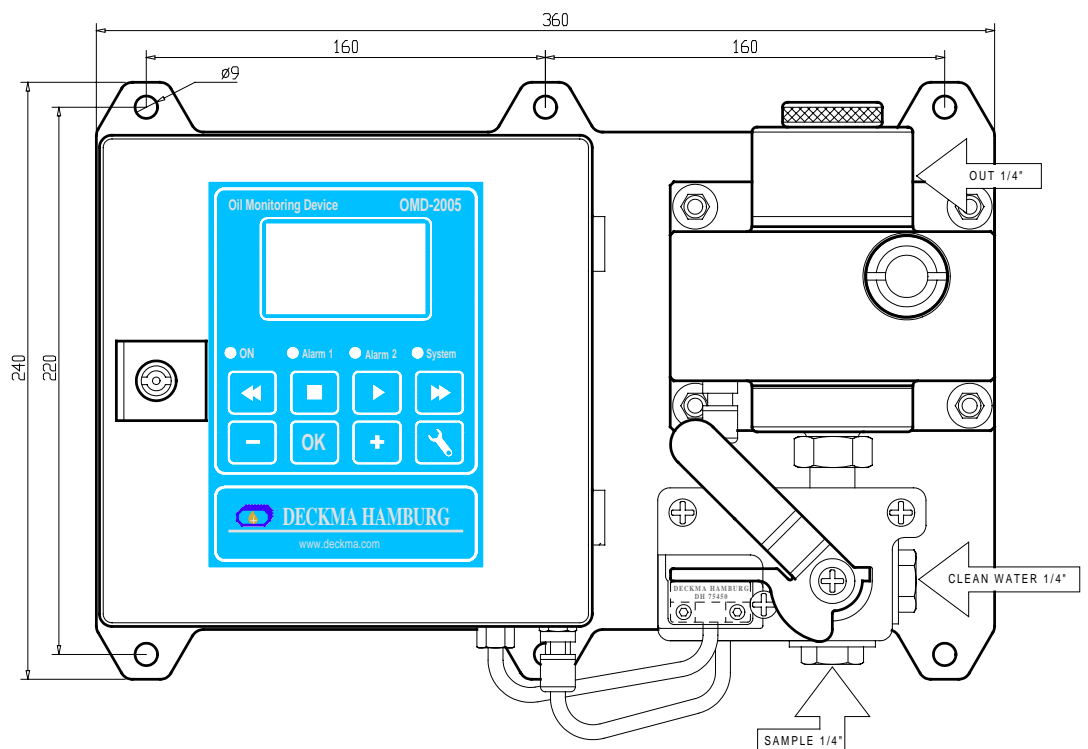
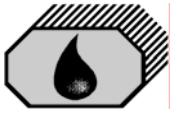

Fig. 2



## 7.0 PIPING (Refer to Fig. 3)

Connect the OMD-2005 Monitor to the sample point of the oily-water separator outlet and to a source of oil free water employing 10 mm OD copper or stainless steel pipe. The sample point should be located on a vertical section of the separator outflow piping to minimize the effects of any entrained air. The tapping point should be at a level above the outlet of the monitor to ensure the sample cell is flooded at all times.

If connection to a vertical section of the separator outlet piping is impractical, the tapping may be made into the side of the horizontal pipe. Avoid top or bottom entry.

For separator discharge pipes up to 75 mm OD a standard "T"-type junction of the welded or screwed type is satisfactory for the tapping point. For the separator discharge pipes of 80 mm OD and above a sample probe should be employed which protrudes into the discharge piping by approx. 25 % of the ID of the pipe.

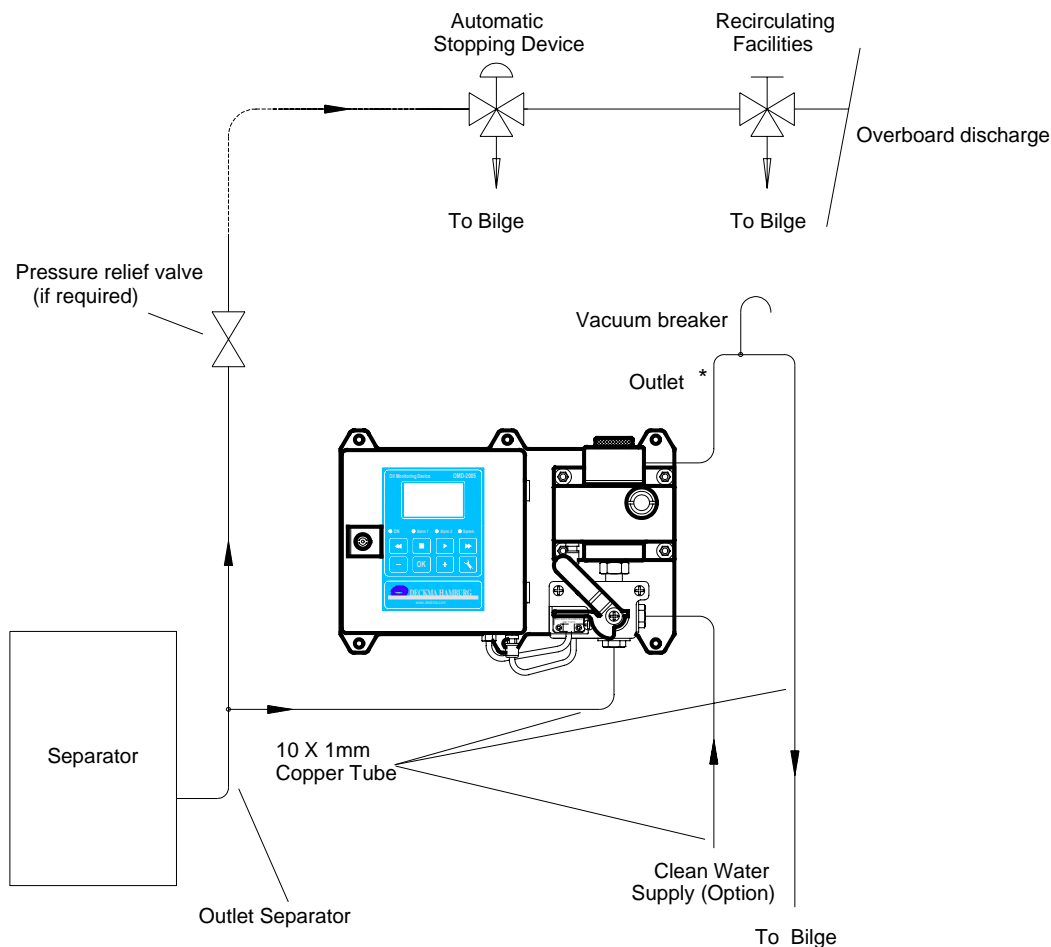

\* Inlet & Outlet connections R1/4" Female

Fig. 3

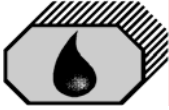

## 8.0 WIRING (Refer to Fig. 4 + 5)

See Section 2 for important notes concerning wiring.

This unit must be connected to the mains supply via a suitable rated and approved fused isolator unless such fusing / isolation is provided by associated equipment. When fitted, the isolator should be close, readily accessible and marked as to function.

Electrical connections are made through the metric cable gland openings prepared underneath the instrument.

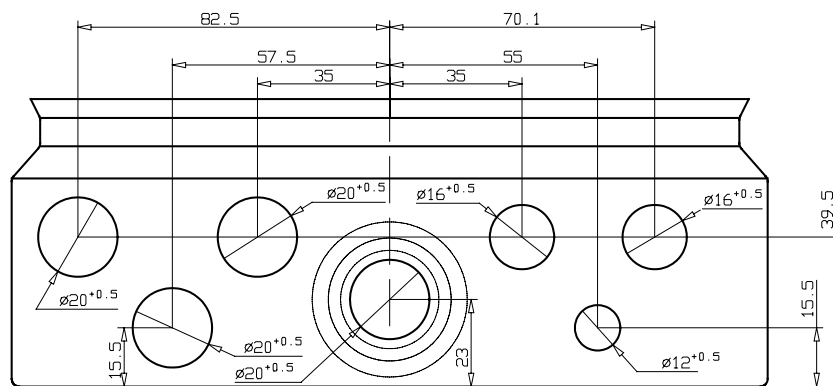

Fig. 4

Precise wiring details will vary dependent upon the control system to be employed but the most frequently used systems employ alarm relay 1 for alarm only and alarm relay 2 for control purposes.

Electrical connections are made to the terminal blocks inside the computer housing. Wires are connected to the terminals by pushing a suitable screwdriver into the clamp holes to release the internal spring loaded clamps. After the wire is inserted to the terminal and the screwdriver is removed, the wire is fixed.

If the instrument is operated at high voltages, additional care has to be taken to provide reliable ground connections. Ground (PE) can be connected direct to the terminal or, if this is not sufficient according local rules, to the computer housing left side. In this case the plug needs to be replaced by a M6 screw with nut and related washers.

The instrument provides a pilot voltage output at terminals 4&5. This is internally connected to the power supply input (Terminals 1&2), but is fused by Fuse F1 (2 A). The pilot voltage can be used to supply additional external circuitry, e.g. alarm lamps or electrical valves.

*Please note: any device connected to the pilot voltage output must be rated for the voltage the instrument is supplied with. Do not use the pilot voltage for driving motors, heaters or other high load devices. The pilot voltage is intended for alarm purposes only.*

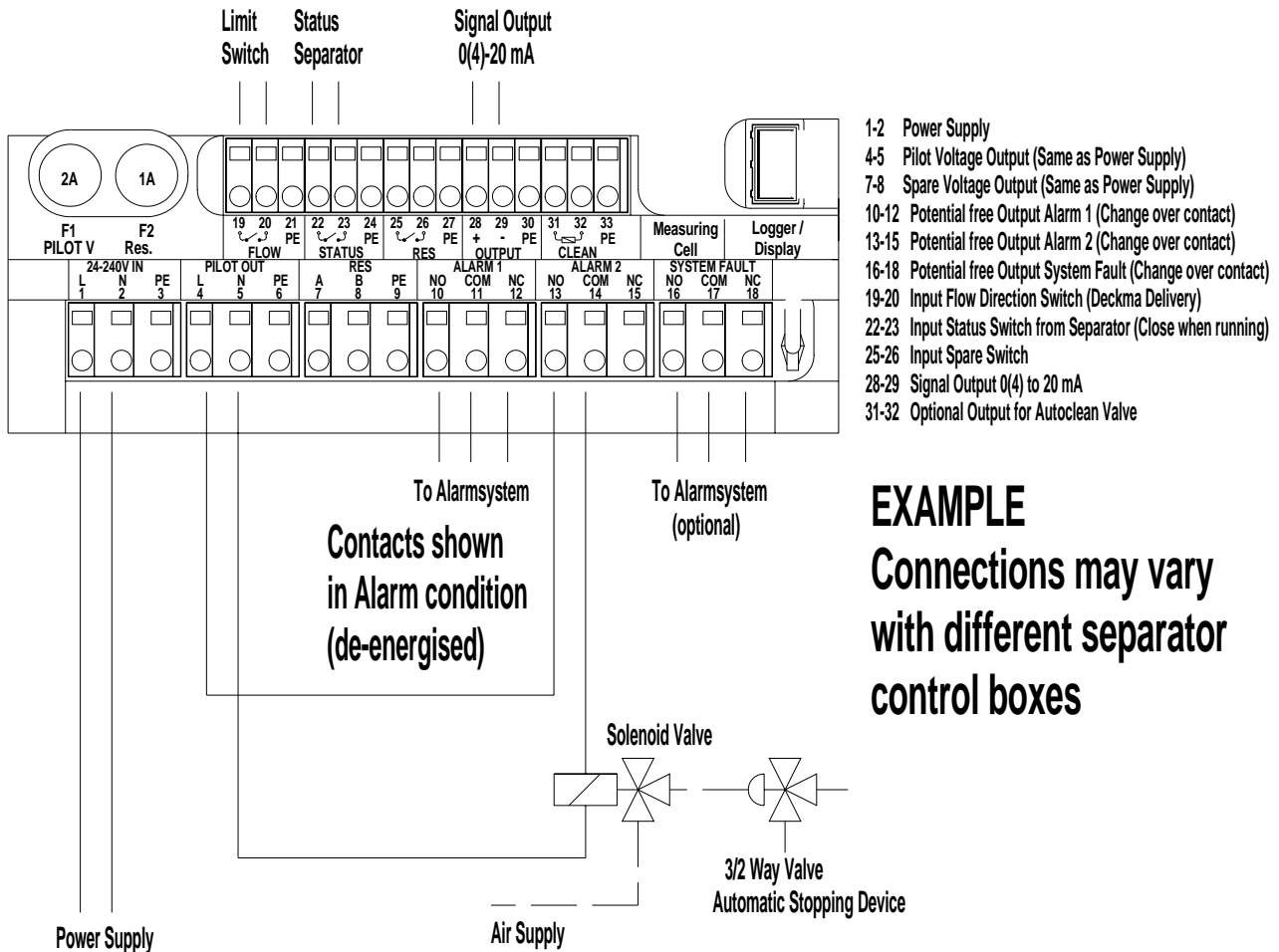
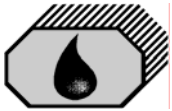
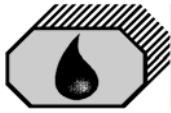

Fig. 5

*Close front door complete after electrical installation. Water inside the instrument may result in corrosion and malfunction.*



## 8.1 Typical Control System

The installation on site has to make sure that in case of any loss of power supply and/or loss of air supply for the automatic stopping device the overboard discharge valve close the overboard line and open the re-circulating line.

The system showed in the example, employs alarm relay 2 to control a pneumatic solenoid valve which energises or de-energises a pneumatically operated 3 - way valve as depicted in Fig. 5.

The separation process will continue until such time as the pollution level falls below the alarm set point at which time the discharge will be directed overboard.

A pump stop system is according MEPC.107 (49) not allowed.

## 9.0 POWER SUPPLY

*See Section 2 for important notes.*

The unit is designed for a power supply of 24 V to 240 V AC or DC. It has an automatic power selection.

## 10.0 COMMISSIONING

*See Section 2 for important notes.*

On completion of the installation, wiring and piping carry out the following checks:

### 10.1 Electrical

- a) Check that the power supply is connected to the terminals 1 + 2 of the terminal block.
- b) Check the wiring of the automatic stopping device and to the alarm system is according the IMO Requirements.
- c) Check that the grounding has been made according to the relevant regulations.

### 10.2 Piping

- a) Check all piping connections for leaks and rectify as appropriate.

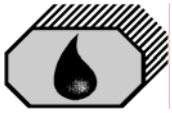

## 10.3 Functional Tests

- a) Run oil free water through the instrument to purge the system.
- b) Adjust the flow rate through the unit by using the small screws in the cell cap (Fig. 1, Pos. 2). Taking out a screw will increase the flow rate.

**NB:** The flow rate should be checked on both, the clean water supply and the separator sample supply. If the clean water supply is obtained from a high pressure source, the flow rate will be higher than from the sample point.

*The flow rate is not influencing the accuracy of the instrument. The adjustment is only important for the time delay between the sample point and the monitor.*

- c) Switch on the instrument and make sure, that the Power LED is illuminated and the display is showing the initializing display for about 15 sec. After that time it will change to the standard display, showing the actual measurement.

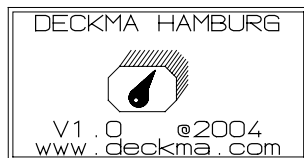

- d) During oil free water is running through the monitor check the Zero adjustment according Section 11. The display should be "0" to "2" and the status will show "FW". If the display varies by greater amounts, it may be that air entrainment is present. If this is the case, the cause must be located and rectified.
- f) If the Zero need to be adjusted, this can be done in the programming mode as described in section 10.4. (Service – Offset)

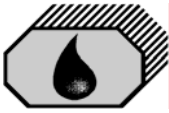

## 10.4 Programming Mode

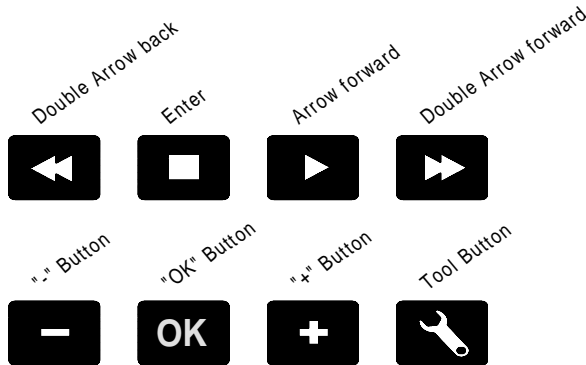

In the programming mode the alarm set points, the time delays, the signal output and the zero can be modified. It is also possible to recall the factory default values at any time. The clock is factory set for GMT, **Greenwich Mean Time**, and cannot be changed.

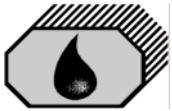

There are 8 push buttons to control the functions of the display. In general are the upper buttons for the data logger and the lower buttons for changing the display to the different pages of the menu.

|   |  |   |
|---|--|---|
|   | <p>Pressing the OK button will give more detailed information about the status</p>   |   |
| <p>After start the display will show the initial display followed by the actual measured oil content. This display also be shown, if no input at the different menu's has been done for a designated time</p> |  |   |
|   |  |   |
| <p>To get into the menu press the tool button. Select the required point by using the „+“ or „-“, button. Press the „OK“ button.</p>  | <p>At the service menu the alarms, time delays, the Offset and the output signal can be modified within the limitations. Select the required point by using the „+“ or „-“, button. Press the „OK“ button.</p> | <p>To change the value, press the „+“ or „-“ button. Confirm with „OK“.</p> |

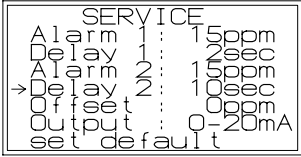
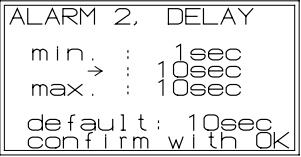
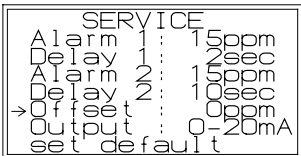
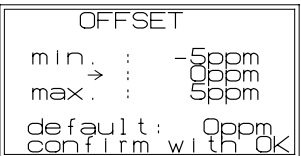

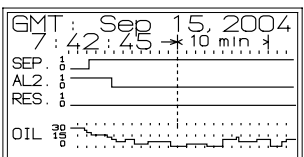
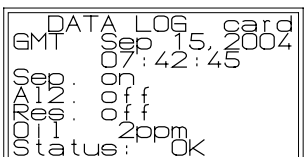
|   |  |   |
|---|--|---|
|   |   |    |
|   | <p>Select the required point by using the „+“ or „-“, button. Press the „OK“ button.</p>   | <p>To change the value, press the „+“ or „-“ button. Confirm with „OK“.</p>   |
|   |   |    |
|   | <p>Select the required point by using the „+“ or „-“, button. Press the „OK“ button.</p>   | <p>To change the value, press the „+“ or „-“ button. Confirm with „OK“.</p>   |
|   |    |   |
| <p>To get into the menu press the tool button. Select the required point by using the „+“ or „-“, button. Press the „OK“ button.</p>  | <p>The display will show the actual status of the data logger. To get back to the standard display press the tool button or the OK button.</p>   |   |
|   |   |    |
| <p>Function of the scrolling buttons for both operation time history displays:</p> <ul style="list-style-type: none"> <li>&gt; 15 sec Forward</li> <li>&gt; and + 2 min Forward</li> <li>&gt;&gt; Fast Forward</li> <li>&gt;&gt; and + Very Fast Forward</li> <li>- 15 sec Backward</li> <li>- and + 2 min Backward</li> <li>&lt;&lt; Fast Backward</li> <li>&lt;&lt; and + Very Fast Backward</li> </ul> | <p>Press the “Enter” button to get into the history. Select the required date and time by using the buttons.<br/>The dotted vertical line shows the actual position.</p> <p>Press the “Enter” button to show details</p> | <p>The detailed information of the selected date and time will be displayed. To get back to the history graph, press the “Enter” Button again. To get back to the start display, press the “OK” button.</p> |



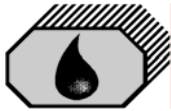

|   |   |  |
|---|---|--|
| <pre> MENU Service data logger →additional info about OMD-2005 about DECKMA           </pre>  | <pre> ADDITIONAL INFO Temperature sample: 24°C m.cell: 25°C           </pre>  |  |
| <p>To get into the menu press the tool button. Select the required point by using the „+“ or „-“ button. Press the „OK“ button.</p> | <p>The temperature of the measuring cell and the sample water will be shown</p>   |  |
| <pre> MENU Service data logger additional info →about OMD-2005 about DECKMA           </pre>  | <pre> SYSTEM DEVICE: OMD-2005 Ser.No: 1001001 -Date: 09/2004 Certif: 1071491 -App: 09/2004 Output: 0-30ppm           </pre>                         |  |
| <p>To get into the menu press the tool button. Select the required point by using the „+“ or „-“ button. Press the „OK“ button.</p> | <p>The details of the measuring cell will be shown.</p>   |  |
| <pre> MENU Service data logger additional info about OMD-2005 →about DECKMA           </pre>  | <pre> DECKMA HAMBURG  V1.0 @2004 www.deckma.com           </pre> |  |
| <p>To get into the menu press the tool button. Select the required point by using the „+“ or „-“ button. Press the „OK“ button.</p> | <p>Information about the software version and the web address will be shown.</p>  |  |

**NB:** All changed values have to be confirmed by pressing the " OK " button. Otherwise the existing values are valid.

## 11.0 OPERATING INSTRUCTIONS

- a) Switch on the power supply.
- b) Allow a period of time for water entering the sample tube.
- c) Flow oil free water through the system for a few minutes and check that the display show 0 to 2 ppm. If not, clean proper before adjusting the unit according section 10.4 "Service - Offset".
- d) Switch the instrument sample supply from the clean water supply to the separator sampling point connection.
- e) The instrument is now ready for use.

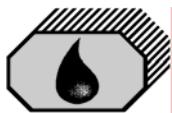

## 11.1 Operator Notes

- a) When oily water flows through the instrument the display will show the actual value of oil content.
- b) If the oil concentration exceeds the adjusted threshold (works adjustment 15 ppm), the alarm indicator 1 will be illuminated in intervals during the selected time delay before it change to steady light and the associated alarm relay will operate. Accordingly also the alarm indicator 2 will be illuminated and its associated alarm relay will take the appropriate shut down action.

## 12.0 OPERATOR MAINTENANCE

*See Section 2 for important notes.*

AT WEEKLY INTERVALS:

- a) Flush the cell with oil free water.
- b) Isolate the instrument from both, sample and oil free water supply.
- c) Unscrew and remove the cell cap.
- d) Insert a suitable Cell Cleaning brush (Art. No. 30102) into the cell and clean it with upwards and downwards motion through the entire length of the cell several times.
- e) Remove the Cell Cleaning brush and replace the cell cap.
- f) Reconnect the oil free water supply and allow this to flow through the instrument for a few minutes.
- g) Observe that the display is showing "0" to "2". If not, clean again.
- h) Examine the color of the desiccator (Fig. 1, Pos. 11). Blue color is indicating an active moisture absorber. If the color is light blue or white, the desiccator should be replaced.

The desiccator assures a humidity below 40% inside the measuring cell to avoid wrong measurement resulting due to condensation at the cell glass tube and damage of the electronics around the glass tube. The replacement is easy done without opening the instrument. Just unscrew the old desiccator out of the front panel and replace it by a new one. The protection cap of the spare unit can be also used as a tool.

- j) Reconnect the instrument to the separator sampling point.

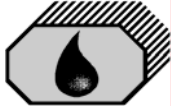

## 12.1 Manual Cell Clean Unit

*Optional item if fitted*

This unit facilitates cleaning of the cell without the need of removing the cell cap. Regular use of this device should prevent malfunction of the monitor due simply to fouling of the sample tube and all the inconvenience which this can cause.

### **Operating Instructions**

- a) Ensure that the monitor is switched off and that there is a clean water supply through the cell.
- b) Activate the manual cell clean unit by pressing the handle several times.
- c) Switch the monitor back on and check the reading is between 0 to 2 ppm.
- d) Repeat a) to c) at least once a week or as necessary.

**NB:** The Manual Cell Clean Unit may also be used during normal operation with sample water, but in this case an alarm occurs because the wiper is passing the light source.

Spares: Wiper Seal, Part. No. 30605

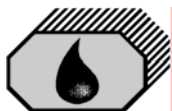

## 13.0 FAULT FINDING

See Section 2 for important notes.

The OMD-2005 will indicate several malfunctions in the status line of the display. Pressing the "OK" button will lead into an information window, similar to the items listed in the table below.

| Status   | Reading    | System-Alarm-circuit |       | Alarm-circuit 1,2 | Reason   | Servicing   |
|----------|------------|----------------------|-------|-------------------|--|---|
|          |            | LED                  | Alarm |                   |  |   |
| OK       | 0..49      | Green / Blinking     | No    | Normal operation  | Normal operation   | -   |
| OK       | EE         | Green / Blinking     | No    | Alarm             | Sample reading is out of range:<br>Oil content too high, dirty sample tube   | Wait until oil content is within the range, clean sample tube |
| FW!      | 0..49 / EE | Green / Blinking     | No    | Alarm             | Freshwater is enabled  | -   |
| Sample?  | EE         | Red / Steady         | Yes   | Alarm             | Meter is not able to measure the sample:<br>no water in, oil content much too high, no light transmission possible | Check sample, clean sample tube                               |
| Com?     | EE         | Red / Steady         | Yes   | Alarm             | No communication between computer unit and measuring cell  | Check connection between computer unit and measuring cell     |
| Datalog? | 0..49 / EE | Red / Steady         | Yes   | Alarm             | Datalogging is not possible:<br>no DECKMA card in  | Insert the active memory card                                 |
|          |            |                      |       |                   | Datalogging is not possible:<br>a read only card is in   | Insert the active memory card                                 |
|          |            |                      |       |                   | Datalogging is not possible:<br>a new DECKMA card is in  | Activate card or insert the active memory card                |
| Int.Err  |            | Red / Steady         | Yes   | Alarm             | Internal error   | Restart the system  |

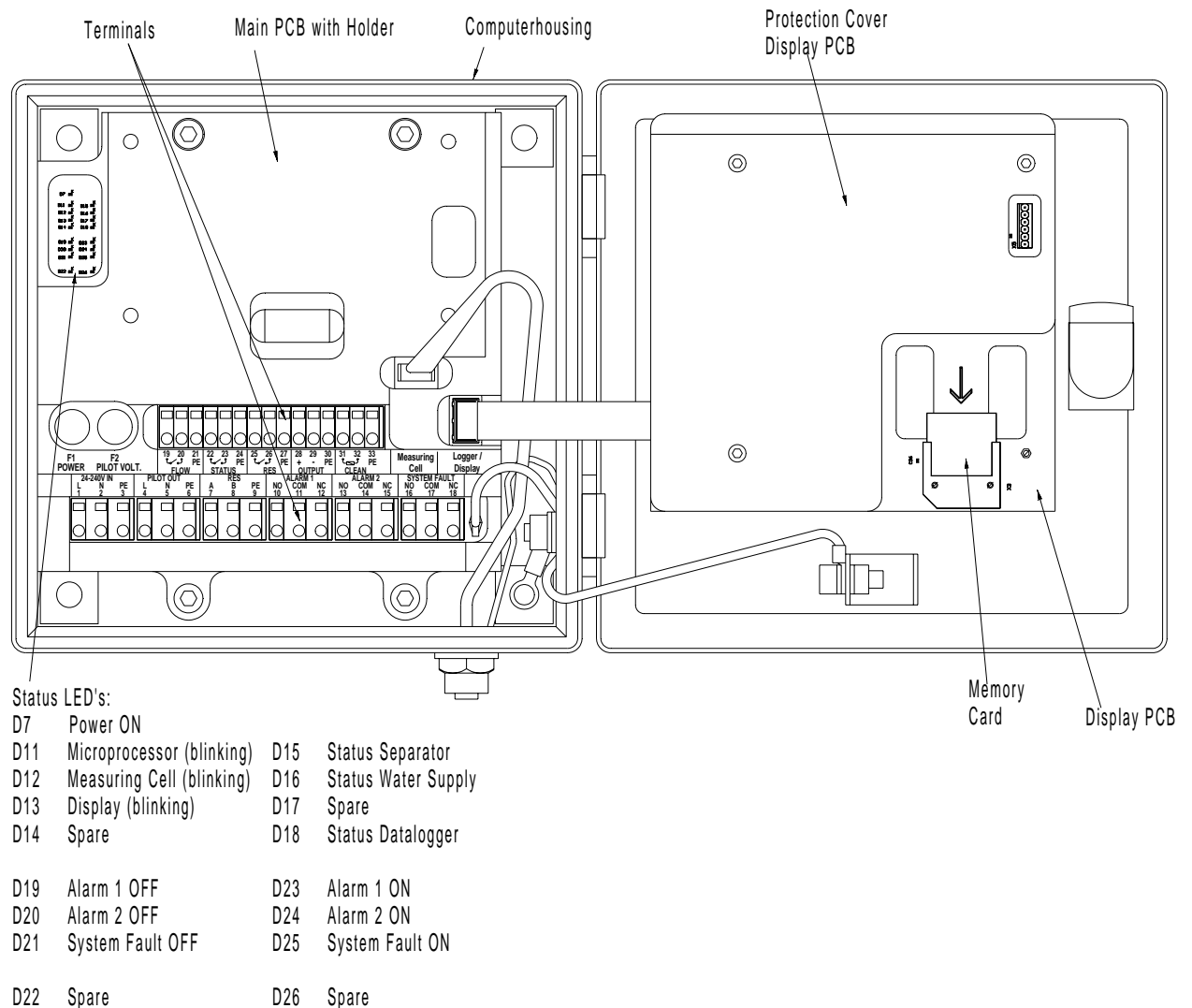
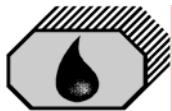

Fig. 6

### 13.1 Memory Card (refer to Fig. 6)

The Memory Card is located inside the door of the computer housing. It is suitable for the life of the instrument, as it is calculated to the according MEPC 107(49) required storage time of at least 18 month. When the card is full, the oldest entry will be overwritten, so that a replacement is not necessary. Under normal use the card should not be taken out, as this is linked with the specific system. The card can be read in other OMD-2005 units, but writing is only possible in the related system.



## 14.0 CALIBRATION

15 ppm Bilge Alarms built according MEPC.107(49) have to be protected against access beyond the checks of instrument drift, repeatability of the instrument reading and zero adjustment. For this reason the instrument is electronically sealed, so that only the manufacturer or his authorized persons, equipped with the related tools, are able to get access for changing the calibration.

To provide a simple procedure for check the instrument aboard ship, the OMD-2005 is constructed in that way, that the zero check also confirms the instrument drift within the specifications.

### 14.1 Calibration and repeatability check

- a) Switch off the power supply and stop any water flow.
- e) Clean the sample tube accurate by using a suitable cell cleaning brush as described under Section 12.0. Make sure, that the offset is correct at  $\pm 0$ .
- f) Run clean water through the instrument.
- g) If it is sure, that non aerated, clean water is in the instrument, the reading should be  $0 \text{ ppm} \pm 2 \text{ ppm}$ .
- a) Continue as described under Section 11.0.

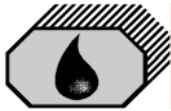

## 15.0 SPARE PARTS

When ordering spares, it is important to supply details of the type of monitor, part number of each spare required, its description and any relevant serial number.

| DESCRIPTION                                 | ART-NUMBER  |
|---|-------------|
| Desiccator                                  | 65550       |
| Cell Cleaning Brush                         | 30102       |
| O-Ring Set                                  | 75775       |
| Fuse, T 2 A                                 | 40107       |
| Fuse, T 1 A                                 | 40105       |
|   |             |
| Measuring Cell with Calibration Certificate | 75500/17300 |
|   |             |

### 15.1 Recommended On Board Spares

|                              |       |
|------------------------------|-------|
| 2 off Desiccator             | 65550 |
| 1 off Cell Cleaning Brush    | 30102 |
| 1 off O-Ring Set             | 75775 |
| 2 off Fuse T 2 A             | 40107 |
|                              |       |
|                              |       |
| Optional item                |       |
| 1 off Manual Cell Clean Unit | 75780 |

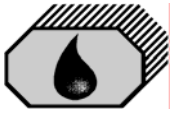

## 16.0 REMARKS

All the modifications and deviations from the standard form, which have to be carried out in the supply, should be attached at this paragraph.

Commissioned on: ..... by: .....  
Date Firm's Name

Remarks:

---

---

---

---

---

---

---

---



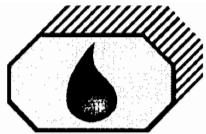

# DECKMA HAMBURG GmbH

DECKMA Decksmaschinen und Automation Vertriebsgesellschaft in Hamburg mbH

DECKMA HAMBURG GmbH • Kieler Straße 316 • 22525 Hamburg • Germany

**Works/Office/Delivery Address:**

Kieler Straße 316  
22525 Hamburg  
Germany

Telephone: +49 (0)40 54 88 76 - 0

Telefax: +49 (0)40 54 88 76 - 10

E-Mail: post@deckma.com

Internet: www.deckma.com

VAT-Registration No.: DE 118 540 659

TO WHOM IT MAY CONCERN

Your Ref.:

Your letter dated:

Our Ref.:

Date: 28.09.2004

## DECLARATION OF CONFORMITY

We, DECKMA HAMBURG GmbH,  
declare under our own responsibility that the product

15 ppm Bilge Alarm, Type: OMD-2005

is in accordance to

MARPOL 73/78, Annex I, Reg. 16, IMO- Resolution MEPC.107 (49) and the  
Maritime Equipment Directive 96/98 EC of the council, Annex B, Module F, Section 5,  
of 20. December 1996 (MED).

DECKMA HAMBURG GmbH

  
ppa. Wolfgang Rathjen



# TYPENZULASSUNGSZEUGNIS

## für 15 ppm Bilge Alarm

Certificate of Type Approval for  
15 ppm Bilge Alarm

Ausgestellt im Namen der Regierung der  
**BUNDESREPUBLIK DEUTSCHLAND**  
durch die **SEE-BERUFGENOSSENSCHAFT**  
*Issued under the authority  
of the Government of the FEDERAL REPUBLIC OF GERMANY  
by See-Berufsgenossenschaft*

Hiermit wird bescheinigt, dass der 15 ppm Bilge Alarm, die nachstehend aufgeführten Anlageteile umfasst, einer Prüfung unterzogen und gemäß den Anforderungen der technischen Beschreibung, enthalten in Teil 2 der Anlage zur Empfehlung der IMO-Entscheidung MEPC.107(49), erprobt wurde.

*This is to certify that the 15 ppm Bilge Alarm, comprising the equipment listed below, has been examined and tested in accordance with the requirements of the specifications contained in part 2 of the annex to the Guidelines and Specifications contained in IMO-Resolution MEPC.107(49).*

Dieses Zeugnis ist nur für nachstehendes Ölgehaltsmessgerät gültig.

*This certificate is valid only for the 15 ppm Bilge Alarm referred to below.*

15 ppm Bilge Alarm geliefert durch: DECKMA HAMBURG GmbH, Kieler Straße 316, D-22525 Hamburg,  
*15 ppm Bilge Alarm supplied by:*

Typbezeichnung: OMD 2005  
*under type and model designation and incorporating:*

Die Analyse-Einheit des 15 ppm Bilge Alarms wurde hergestellt durch: DECKMA HAMBURG GmbH  
*15 ppm Bilge Alarm analysing unit manufactured by:*

Zusammenstellungszeichnung Nr.: 10750-10, 10750-50 Datum: 13.09.2004  
*to specification/assembly drawing No.:* DH75500 / DH75600, DH75610 *date:* 24.06.2004/09.09.2004

Der elektronische Teil des 15 ppm Bilge Alarms wurde hergestellt durch: DECKMA HAMBURG GmbH  
*Electronic section of 15 ppm Bilge Alarm manufactured by:*

Zusammenstellungszeichnung Nr.: 10750-10, 10750-50 Datum: 13.09.2004  
*to specification/assembly drawing No.:* DH75100 / DH75200, DH75300 *date:* 24.06.2004/09.09.2004

Versorgungspumpe hergestellt durch: --  
*Sample feed pump manufactured by:*

Zusammenstellungszeichnung Nr.: -- Datum: --  
*to specification/assembly drawing No.:* *date:*

Probenaufbereitungseinheit hergestellt durch: --  
*Sample conditioning unit manufactured by:*

Zusammenstellungszeichnung Nr.: -- Datum: --  
*to specification/assembly drawing No.:* *date:*

Der 15 ppm Bilge Alarm ist für die Verwendung gemäß Regel 16(5) geeignet.

*The 15 ppm Bilge Alarm is acceptable for use in accordance with regulation 16(5).*

Eine Kopie dieses Zeugnisses soll jederzeit auf jedem Schiff mitgeführt werden, das mit diesem 15 ppm Bilge Alarm ausgerüstet ist.

*A copy of this Certificate should be carried aboard a vessel fitted with this 15 ppm Bilge Alarm at all times.*

Dieses Typenzulassungszeugnis bleibt über das nachstehende Datum hinaus in Kraft, sofern kein Widerruf erfolgt. Ein Widerruf für auf einem Schiff eingebaute Einrichtungen kann z.B. erfolgen, wenn diese nicht gefahren und/oder nicht gewartet und/oder nicht funktionsbereit sind und/oder nicht innerhalb einer angemessenen Frist an zukünftige Bestimmungen angepasst werden können.

*This certificate of type approval is in force beyond the below mentioned date unless it is revoked.*

*A revocation of the equipment installed aboard the ship can follow, but is not limited to, if the equipment is not maintained and/or is not in good working order and/or the equipment can not be modified within an appropriate time frame, due to future regulatory standards.*

Daten und Ergebnisse der Erprobungen siehe Anhang.

*Test data and results attached as Appendix.*

Dieses Typenzulassungszeugnis ist gültig bis: 30.09.2009  
*This certificate of type approval is valid until:*

Ausgestellt in Hamburg am: 29.09.2004  
*Issued at Hamburg on:*

Zulassungs-Nr.: 320 028  
*Certificate-No.:*



**SEE-BERUFGENOSSENSCHAFT**  
**- SCHIFFSSICHERHEITABTEILUNG -**

*i. A. Seifert*

Unterschrift  
*Signature*

## Anhang zum Typenzulassungszeugnis für 15 ppm Bilge Alarm

*Appendix to the certificate of type approval for an 15 ppm Bilge Alarm*

**Daten und Ergebnisse der Erprobungen, durchgeführt an einem 15 ppm Bilge Alarm gemäß Teil 2 der Anlage zu den Richtlinien und Anforderungen der IMO-Entschießung MEPC.107(49).**

*Test data and results of tests conducted on a 15 ppm Bilge Alarm in accordance with Part 2 of the Annex to the guidelines and specifications contained in IMO-Resolution MEPC.107(49).*

**15 ppm Bilge Alarm vorgestellt durch:** DECKMA HAMBURG GmbH  
*15 ppm Bilge Alarm submitted by:*

**Ort der Erprobungen:** DECKMA HAMBURG GmbH, Kieler Straße 316, D 22525 Hamburg.  
*Test location:*

**Stelle, die die Prüfung durchgeführt hat:** See-Berufsgenossenschaft Hamburg  
*Organization conducting the test:*

**Verfahren der Probenanalysen:** IMO-Verfahren gemäß Entschießung MEPC.107(49) (ISO 9377-2)  
*Method of sample analysis:* IMO-method acc. to resolution MEPC.107(49) (ISO 9377-2)

**Analysen der Proben durch:** Institut Fresenius GmbH, Im Maisel 14, D-65232 Taunusstein-Neuhof  
*Samples analysed by:*

**Die Erprobung des elektronischen Teils des 15 ppm Bilge Alarms ist unter Umweltbedingungen gemäß Teil 3 der Anlage zu den Richtlinien und Anforderungen der IMO-Entschießung MEPC.107(49) durchgeführt worden. Die Anlage arbeitete bei Beendigung der jeweiligen Erprobung, die im Bericht über die Prüfung bei Umgebungsbedingungen festgelegt ist, zufriedenstellend.**

*Environmental testing of the electronic section of the 15 ppm Bilge Alarm has been carried out in accordance with part 3 of the annex to the Guidelines and Specifications contained in IMO resolution MEPC.107(49). The equipment functioned satisfactorily on completion of each test specified on the environmental test protocol.*

**Empfehlungen und Informationen des Herstellers über den Gebrauch von Reinigungsmitteln.**  
*Manufacturers' recommendations and information concerning the use of cleansing agents*

**Verwendung von schnell trennenden Reinigungsmitteln.**  
.....  
*Detergents of quick separating type.*  
.....  
.....

---

**Der 15 ppm Bilge Alarm Serien-Nr.:** ..... **entspricht dem geprüften Typ.**  
*The 15 ppm Bilge Alarm serial No.:* ..... *complies with the tested type.*

|              |              |                                    |                     |
|--------------|--------------|------------------------------------|---------------------|
| .....        | .....        | <b>Firmen-</b><br><b>stempel -</b> | .....               |
| <b>Ort</b>   | <b>Datum</b> | <i>Company</i>                     | <b>Unterschrift</b> |
| <i>Place</i> | <i>date</i>  | <i>stamp</i>                       | <i>Signature</i>    |



**See-Berufsgenossenschaft  
Prüf- und Zertifizierungsstelle  
im BG-PRÜFZERT**

**European notified body  
Identification number 0736**

## EC-Type Examination (Module B) Certificate

Certificate-No. **320.028**

Name and address of the manufacturer: **DECKMA Hamburg GmbH, Kieler Straße 316, 22525 Hamburg, Germany**

Date of issue: **27.03.2006**

Annex A.1 Item No & Item designation: **A.1/2.3 - Oil-content meters**

Product designation: **Oil-in-water monitor**

Product Type: **OMD - 2005**

Intended purpose: **Oil content meter (15-ppm alarm) for oily water separating equipment on sea going vessels acc. MARPOL 73/78, Annex I**

Testing based on (Specific standard): **IMO Resolution MEPC.107(49) for oil content meters and oily water separating equipment in acc. with MARPOL 73/78, Annex I, Reg. 16**

Remarks:

The type tested was found to be in compliance with the Marine-pollution prevention requirements of Marine Equipment Directive (MED) 96/98/EC as amended by Directive 2002/75/EC subject to any conditions in the schedule (part of this certificate).

This certificate may only be used in connection with module(s) **D or F or E** of this directive.

Expiry date: **30.09.2009**

*Seifert*  
Signature (Seifert)

The approval of the installed equipment will be in force beyond the validity date until it is revoked!

**Note 1: This certificate will not be valid if the manufacturer makes any changes or modifications to the approved equipment, which have not been notified to, and agreed with the notified body named on this certificate.**

**Note 2: Should the specified regulations or standards be amended during the validity of this certificate, the product(s) is/are to be re-approved prior to it/they being placed on board vessels to which the amended regulations or standards apply.**

**Note 3: The Mark of Conformity may only be affixed to the above type approved equipment and a Manufacturer's Declaration of Conformity issued when the production-control phase module (D, E, or F) of ANNEX B of the Directive is fully complied with and controlled by a written inspection agreement with a notified body.**

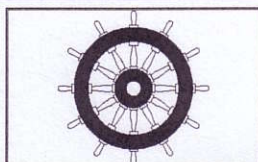

xxxx/yy

**Note 4: "Wheelmark" Format**

YY Last two digits of year mark affixed.

XXXX Notified Body number undertaking surveillance module



Postal address:  
Postfach 11 04 89  
20404 Hamburg

Office:  
Reimerstwiete 2  
20457 Hamburg

Tel: 0 40/3 61 37-0  
Fax: 0 40/3 61 37 2 04

In any case, the German original shall prevail.





U. S. Department of Homeland Security  
**United States Coast Guard**  
**Certificate of Approval**

Coast Guard Approval Number: 162.050/9021/0

Expires: 14 July 2010

OIL POLLUTION PREVENTION EQUIPMENT  
The following device has been tested in accordance  
with IMO Resolution MEPC.107(49)

DECKMA HAMBURG GmbH  
Kieler Strabe 316  
HAMBURG D-22525  
GERMANY

OMD - 2005; 15 ppm Bilge Alarm

Equipment manufactured by DECKMA HAMBURG GmbH to specification/assembly drawing no. 10750-10 and 10750-50 dated 09/13/2004; DH 75500, DH 75600, and DH 75610 dated 06/24/2004 and 09/09/2004. Control equipment manufactured by DECKMA HAMBURG GmbH to specification/assembly drawing no. 10750-10 and 10750-50 dated 09/13/2004, and DH 75100, DH 75200, DH 75300 dated 06/24/2004 and 09/09/2004.

A copy of this certificate should be carried aboard a vessel fitted with this equipment at all times. IMO Certificates of Type Approval do not expire and are valid for equipment manufactured at any time during the period of validity of this certificate. Test data and results attached in the appendix.

\*\*\* END \*\*\*

THIS IS TO CERTIFY THAT the above named manufacturer has submitted to the undersigned satisfactory evidence that the item specified herein complies with the applicable laws and regulations as outlined on the reverse side of this Certificate, and approval is hereby given. This approval shall be in effect until the expiration date hereon unless sooner canceled or suspended by proper authority.



GIVEN UNDER MY HAND THIS 14<sup>th</sup> DAY OF  
JULY 2005, AT WASHINGTON D.C.

B. G. BUBAR  
Chief, Engineering Division  
U.S. Coast Guard Marine Safety Center



Certificate number CBA-016  
 Certificat numéro

**CERTIFICATE OF TYPE TEST FOR OIL CONTENT METERS INTENDED FOR BILGE ALARMS**  
**CERTIFICAT D'AGRÉMENT PAR TYPE DES DÉTECTEURS D'HYDROCARBURES DESTINÉS AUX ALARMES POUR EAUX DE CALE**  
 5 - 15 ppm alarm 5 - 15 ppm alarme

This is to certify that the oil content meter, comprising the equipment listed, below has been examined and tested in accordance with the requirements of the Specification contained in Part II of the Annex to the Guidelines and Specifications contained in IMO resolution MEPC 107(49). This Certificate is valid only for an oil content meter referred to below.

*Il est certifié que le détecteur d'hydrocarbures comprenant les éléments ci-après a été examiné et soumis à des essais conformément aux dispositions des spécifications qui font l'objet de la Partie II de l'annexe aux Directives et spécifications contenue dans la résolution 107(49) de l'OMI. Le présent certificat n'est valable que pour un détecteur d'hydrocarbures du type décrit ci-dessous.*

Oil content meter supplied by  
*Détecteur d'hydrocarbures fourni par*  
 under type and model designation  
*type et désignation du modèle:*  
 and incorporating:  
*comportant:*

Oil content meter analysing unit manufactured by  
*Dispositif d'analyse du détecteur d'hydrocarbures fabriqué par*  
 to specification/drawing numbers  
*conformément à la spécification/au schéma n°*  
 Electronic section of oil content meter manufactured by  
*Éléments électronique du détecteur d'hydrocarbures fabriqué par*  
 to specification/drawing numbers  
*conformément à la spécification/au schéma n°*

\* Sample feed pump manufactured by  
*Pompe d'échantillonnage fabriqué par*  
 to specification/drawing numbers  
*conformément à la spécification/au schéma n°*

\* Sample conditioning unit manufactured by  
*Dispositif de conditionnement de l'échantillon fabriqué par*  
 to specification/drawing numbers  
*conformément au schéma n°*

|                             |                       |
|-----------------------------|-----------------------|
| DECKMA HAMBURG GmbH         |                       |
| OMD-2005                    |                       |
| DECKMA HAMBURG GmbH         |                       |
| 10750-10, 10750-50          | date: 09/13/2004      |
| DH 75500/DH 75600, DH 75610 | 06/24/2004 09/09/2004 |
| DECKMA HAMBURG GmbH         |                       |
| 10750-10, 10750-50          | date: 09/13/2004      |
| DH 75100/DH 75200, DH 75300 | 06/24/2004 09/09/2004 |

THE SYSTEM IS ACCEPTABLE FOR THE FOLLOWING APPLICATION:  
 LE DISPOSITIF EST CONÇU POUR LES UTILISATIONS SUIVANTES :

The oil content meter is acceptable for use with a 15 ppm bilge alarm in accordance with regulation 16(5)  
 Le détecteur d'hydrocarbures est acceptable et peut être utilisé avec une alarme à 15 ppm pour eaux de cale conformément à la règle 16(5).

\* This Bilge Alarm meets the specification for a 5 ppm unit, as contained in the "Standard for Performance and Test Specifications for Bilge Alarms for Use in Canadian Inland Waters," in accordance with the Oil Pollution Prevention Regulations.

\* Cette alarme pour eaux de cale satisfait aux spécifications pour une unité à 5 ppm, selon la "Norme de rendement est spécifications d'essais de dispositifs d'alarme pour eaux de cale utilisés sur les navires naviguant dans les eaux intérieures canadiennes", conformément au Règlement sur la Prévention de la pollution par les hydrocarbures.

Test date and results: 15 ppm tests: as per paconsult test report Nr. 436/04 dated August 20th, 2004  
 Les données et résultats des essais : as per Test Protocol Report INSTITUT FRESSENIUS dated October 28, 2004

A COPY OF THIS TEST CERTIFICATE SHOULD BE CARRIED ABOARD A VESSEL FITTED WITH THIS EQUIPMENT AT ALL TIMES  
 UN EXEMPLAIRE DU PRÉSENT CERTIFICAT D'ESSAIS DEVRAIT SE TROUVER EN PERMANENCE A BORD D'UN NAVIRE ÉQUIPÉ DE CE MATÉRIEL



AMSE - C030(06-94)

Matt Cook, Senior Marine Inspector, Environmental Protection

(SIGNATURE OF AUTHORIZED INSPECTOR / SIGNATURE DE L'INSPECTEUR AUTORISÉ)

DATED THIS 29th DAY OF November 2005  
 DATE CE JOUR DE



格式 CP181  
Form

中国船级社

CHINA CLASSIFICATION SOCIETY

编号 HB05T00037  
No.

15 PPM 舱底水报警装置型式认可证书  
CERTIFICATE OF TYPE APPROVAL FOR 15 PPM BILGE ALARM

This is to certify that the 15 ppm Bilge Alarm, comprising the equipment listed below, has been examined and tested in accordance with the requirements of the specifications contained in part 2 of the annex to the Guidelines and Specifications contained in IMO resolution MEPC.107(49).

This Certificate is valid only for the 15 ppm Bilge Alarm referred to below.

15 ppm Bilge Alarm supplied by DECKMA Hamburg GmbH, Hamburg Germany

under type and model designation

and incorporating: OMD 2005

15 ppm Bilge Alarm analysing unit manufactured by DECKMA Hamburg GmbH

|                                       |                           |      |                   |
|---------------------------------------|---------------------------|------|-------------------|
| to specification/assembly drawing No. | <u>10750-10, 10750-50</u> | date | <u>13.09.2004</u> |
|                                       | <u>DH75500, DH75600,</u>  |      | <u>24.06.2004</u> |
|                                       | <u>DH75610</u>            |      | <u>09.09.2004</u> |

Electronic section of 15 ppm Bilge Alarm manufactured by DECKMA Hamburg GmbH

|                                       |                           |      |                   |
|---------------------------------------|---------------------------|------|-------------------|
| to specification/assembly drawing No. | <u>10750-10, 10750-50</u> | date | <u>13.09.2004</u> |
|                                       | <u>DH75100, DH75200,</u>  |      | <u>24.06.2004</u> |
|                                       | <u>DH75300</u>            |      | <u>09.09.2004</u> |

The 15 ppm Bilge Alarm is acceptable for use in accordance with Regulation 16 (5).

A copy of this Certificate should be carried aboard a vessel fitted with this 15 ppm Bilge Alarm at all times.

Test data and results attached as appendix.



Signed [Signature] (Hu Kefeng)  
China Classification Society

Dated this Oct. 27 day of 2005

\*Delete as appropriate.



**СВИДЕТЕЛЬСТВО  
О ТИПОВОМ ОДОБРЕНИИ ДЛЯ СИГНАЛИЗАТОРА  
О СОДЕРЖАНИИ НЕФТИ В СБРОСЕ (15 МЛН<sup>-1</sup>)**

**CERTIFICATE  
OF TYPE APPROVAL FOR 15 PPM BILGE ALARM**

Настоящим удостоверяется, что сигнализатор, включающий перечисленное ниже оборудование, проверен и испытан в соответствии с требованиями части 2 Приложения к Руководству и техническим требованиям, содержащимся в резолюции ИМО МЕРС.107(49). Настоящее Свидетельство действительно только для сигнализатора, указанного ниже.

This is to certify that the 15 ppm bilge alarm, comprising the equipment listed below, has been examined and tested in accordance with the requirements of the specifications contained in part 2 of the Annex to the Guidelines and Specifications contained in IMO resolution МЕРС.107(49). This Certificate is valid only for the 15 ppm bilge alarm referred to below.

Сигнализатор типа и модели OMD-2005  
15 ppm bilge alarm under type and model designation

поставляется Deckma Hamburg GmbH, Keler StraBe 316, D-22525 Hamburg, Germany  
supplied by

и включает  
and incorporating

анализатор содержания нефти, изготовленный DECKMA HAMBURG GmbH  
15 ppm bilge alarm analysing unit manufactured by

по техническим условиям/сборочному чертежу № 10750-10, 10751-50, DH75500, DH75600, DH75610  
to specification/assembly drawing No.

дата 13.09.2004, 24.06.2004, 09.09.2004  
date

электронную секцию сигнализатора, изготовленную DECKMA HAMBURG GmbH  
electronic section of 15 ppm bilge alarm manufactured by

по техническим условиям/сборочному чертежу № 10750-10, 1075050, DH75100, DH75200, DH75300  
to specification/assembly drawing No.

дата 13.09.2004, 24.06.2004, 09.09.2004  
date

\*пробоотборный насос, изготовленный  
\*sampling pump manufactured by

по техническим условиям/сборочному чертежу №  
to specification/assembly drawing No.

13.09.2004, 24.06.2004, 09.09.2004

дата  
date

\*пробоотборное устройство, изготовленное  
\*sampling unit manufactured by



по техническим условиям/сборочному чертежу № \_\_\_\_\_  
to specification/assembly drawing No. \_\_\_\_\_

дата \_\_\_\_\_  
date \_\_\_\_\_

Сигнализатор приемлем для использования в соответствии с правилом 16(5)  
The 15 ppm bilge alarm is acceptable for use in accordance with regulation 16(5)

Копия настоящего Свидетельства должна постоянно находиться на борту судна, оснащенного данным сигнализатором.  
A copy of this Certificate is to be carried aboard a vessel fitted with this 15 ppm bilge alarm at all times.

Исходные данные и результаты испытаний приведены в Дополнении.  
Test data and results attached as Appendix.

№ \_\_\_\_\_  
No. **04.02901.009**

**17 December 2004**

(дата выдачи)  
(date of issue)

Российский морской регистр судоходства  
Russian Maritime Register of Shipping

(подпись уполномоченного лица, выдавшего Свидетельство)  
(signature of authorized official issuing the Certificate)

