



INSTRUMENTS

GX-3R

Operator's Manual

Part Number: 71-0477

Revision: B

Released: 6/22/23

RKI Instruments, Inc.
www.rkiinstruments.com

WARNING

Read and understand this instruction manual before operating instrument. Improper use of the gas monitor could result in bodily harm or death.

Maintenance of the gas monitor is essential for proper operation and correct readings.

Bump test the instrument before each day's use with a known concentration of each target gas. A bump test can be done in User Mode's BUMP item or by applying gas in Measuring Mode. The instrument does not need to be calibrated unless it does not pass the User Mode bump test or does not respond appropriately, as defined by the user, in Measuring Mode. For more information about bump test and calibration requirements, see IEC 60079-29-2.

GX-3R Quick Reference Guide

Turn On
Press & Hold



Past Due Bump/CAL
To Bump / CAL
Confirm & Use

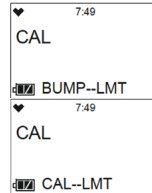

Normal Operation
After brief warm-up period

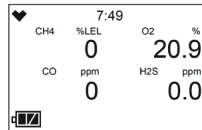

Fresh Air
Press & Hold



Turn Off
Press & Hold



GX-3R Quick Reference Guide

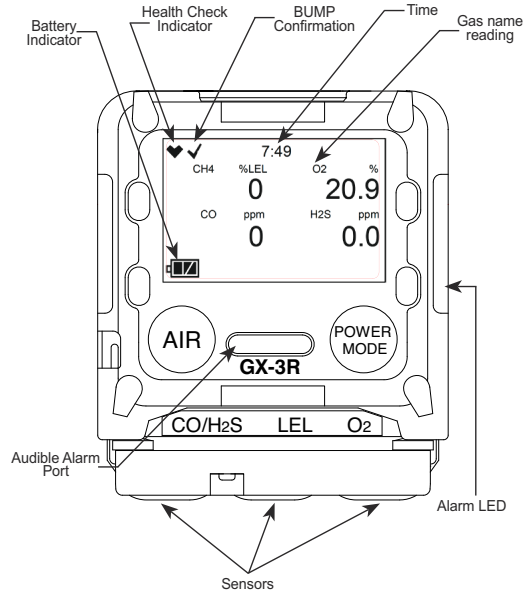

Scan QR code for
GX-3R Manual

RKI Instruments, Inc. 33248 Central Ave, Union City, CA 94587
Phone (510) 441-5656 • (800) 754-5165 • www.rkiinstruments.com
210323/6000



Statement of Quality and Conformance

RKI Instruments, Inc. certifies that this instrument has been tested, inspected, and calibrated by a qualified technician and was found to meet or exceed the manufacturer's specifications per ISO 9001 Quality System.

Register your Product here:
www.rkiinstruments.com/registration

RKI Instruments, Inc. • 33248 Central Avenue, Union City, CA 94587
Phone: (510) 441-5656 • (800) 754-5165 • Fax: (510) 441-5650
www.rkiinstruments.com

Table of Contents

Chapter 1: Introduction	9
Overview	10
About the GX-3R	10
Specifications	11
About this Manual	14
Chapter 2: Description	15
Overview	15
Instrument Description	15
<i>Case</i>	15
<i>LCD</i>	15
<i>Control Buttons</i>	16
<i>Alarm LEDs</i>	16
<i>Buzzer</i>	16
<i>Vibrator</i>	17
<i>Sensors</i>	17
<i>Filters</i>	18
<i>Infrared Communications Port</i>	19
<i>Charging Socket and Battery Pack</i>	19
Included Accessories	20
<i>Alligator Clip</i>	20
<i>Rubber Boot</i>	20
<i>Wrist Strap</i>	20
<i>Single-Unit AC Charger</i>	20
<i>Calibration Cup</i>	21
Other Accessories	21
<i>12 VDC Charger</i>	21
<i>Multi-Unit AC Charger</i>	21
<i>Belt Clip</i>	22
<i>SDM-3R</i>	22

<i>RP-3R</i>	22
<i>Aspirator Adapter</i>	22
<i>IrDA Cable</i>	22
Chapter 3: Operation	23
Overview	23
Start Up	23
<i>Turning On the GX-3R</i>	23
<i>Performing a Demand Zero</i>	30
<i>Turning Off the GX-3R</i>	30
Measuring Mode Operation	31
<i>Monitoring an Area</i>	32
<i>Combustible Gas Detection</i>	32
<i>Oxygen-Enriched Atmospheres</i>	34
<i>H₂-Compensated CO Detection</i>	35
<i>Interference Information</i>	35
<i>Aspirator Adapter Sampling</i>	36
Alarms	37
<i>Alarm Indications</i>	37
<i>Responding to Alarms</i>	40
Data Logging	44
Chapter 4: Display Mode	45
Tips for Using Display Mode	46
Peak Screen (PEAK)	46
STEL Screen (STEL)	47
TWA Screen (TWA)	47
Combustible Sensor Target Gas Conversion (LIST)	48
Changing the User ID (USER ID)	50
Changing the Station ID (STN ID)	51
Last Successful Calibration Date (CAL DATA)	52
Last Successful Bump Test Date (BUMP DATA)	53
Date, Time, and Temperature Screen (TEMP)	53
Viewing Alarm Settings Screen (ALARM--PT)	54

Chapter 5: User Mode and Calibration	55
Overview	55
Entering User Mode	59
Tips for Using User Mode	60
Performing a Bump Test (BUMP)	60
Performing a Calibration (GAS CAL)	67
Setting Calibration Parameters (CAL SET)	79
Setting Bump Test Parameters (BUMP SET)	81
Alarm Settings (ALARM--PT)	86
Updating the Lunch Break Setting (LUNCH)	89
Setting the Confirmation Beep and Non-Compliance Indicator (BEEP)	90
Updating the Backlight Time (BL TIME)	92
Turning the Key Tone On/Off (KEY TONE)	92
Display Mode Items (DISP SET)	93
Zero Suppression (ZERO SUP)	93
Zero Follower (ZERO.FLWR)	94
Setting the Date/Time (DATE)	94
Turning the Password On/Off (PASSWORD)	95
Viewing the ROM/SUM (ROM/SUM)	96
Entering Measuring Mode (START)	96
 Chapter 6: Maintenance	 97
Overview	97
Troubleshooting	97
Instrument Cleaning	98
Recharging the Batteries	98
Replacing the Buzzer Cover	100
Replacing the Sensor Filters	101
<i>Combustible Gas Sensor Filter</i>	<i>101</i>
<i>Dual CO/H₂S Sensor Filter</i>	<i>101</i>
<i>CO-Only Sensor Filter</i>	<i>101</i>
<i>H₂S-Only Sensor Filter</i>	<i>102</i>
Replacing the Hydrophobic Dust Filter	104
Replacing a Sensor	107

Replacing the Battery Board.....	109
Chapter 7: Storage.....	114
Chapter 8: General Parts List	115
Appendix A: Maintenance Mode	118
Overview	118
Entering Maintenance Mode	120
Tips for Using Maintenance Mode	121
Performing a Calibration (GAS CAL)	121
Performing a Gas Test (GAS TEST).....	122
Sensor/Battery Replacement Date (SEN DATE)	124
Performing a Bump Test (BUMP)	125
Setting Alarms to Latching or Self-Resetting (LATCHING).....	126
Turning the Demand Zero Function On/Off (DEM ZERO).....	126
Turning the Auto Zero Function On/Off (AUTOZERO)	127
Turning the ID Display Function On/Off (ID DISP)	127
Turning the Zero Suppression On/Off (ZERO SUP)	128
Turning the Zero Follower On/Off (ZERO.FLWR)	128
User Mode Zero Suppression (ZSUP.DISP).....	128
User Mode Zero Follower (ZFLW.DISP).....	128
Setting the Date/Time (DATE)	129
Turning the Password On/Off (PASSWORD)	129
Viewing the ROM/SUM (ROM/SUM).....	130
Performing a Default (M.DEFAULT).....	131
Entering Measuring Mode (START)	132
Appendix B: Gas Select Mode.....	133
Overview.....	133
Entering Gas Select Mode	133
Tips for Using Gas Select Mode.....	134
Changing the Gas Combination (GAS COMB)	135
Saving the Alarm Points (SAVE-AP)	137
Turning Calibration Max Span On/Off (MAX SPAN).....	138

Stealth and Vibrator Settings (STEALTH)	138
LEL Definition (CHG LEL)	139
Exiting Gas Select Mode (START)	141
Appendix C: Interference Information	142
ESR-A13i-H2S, H ₂ S Detection	142
ESR-A13P-CO, CO Detection	144
ESR-A1CP-COH, H ₂ -Compensated CO Detection	146
ESR-A1DP-COHS, CO Detection	148
ESR-A1DP-COHS, H ₂ S Detection	150
Warranty	152

WARNING: Understand manual before operating. Substitution of components may impair intrinsic safety. To prevent ignition of a hazardous atmosphere, batteries must only be changed or charged in an area known to be nonhazardous.

Chapter 1: Introduction

Overview

This chapter briefly describes the GX-3R gas monitor. This chapter also describes the *GX-3R Operator's Manual* (this document). Table 1 at the end of this chapter lists the specifications for the GX-3R.

About the GX-3R

Using an advanced detection system consisting of up to three gas sensors, the GX-3R personal four-gas monitor detects the presence of combustible gas, oxygen (O₂), carbon monoxide (CO), and hydrogen sulfide (H₂S) simultaneously. This model displays measurement results on an LCD and issue gas alarms (via LED and buzzer) as needed. The GX-3R's compact size and easy-to-use design make it ideally suited for a wide range of applications, including sewage treatment plants, utility manholes, tunnels, hazardous waste sites, power stations, petrochemical refineries, mines, paper mills, drilling rigs, and fire fighting stations. The GX-3R offers a full range of features, including:

- Simultaneous monitoring of one to four gases
- Liquid crystal display (LCD) for complete and understandable information at a glance
- Ultrabright alarm LEDs
- Distinctive audible/vibrating alarms for dangerous gas conditions and audible alarms for unit malfunction
- Microprocessor control for reliability, ease of use, and advanced capabilities
- Data logging functions
- Alarm trend data
- STEL, TWA, and over range alarms
- Peak readings
- Built-in time function
- Lunch break feature
- CSA "C/US" classified as intrinsically safe (see Table 2 on page 11)

WARNING: The Model GX-3R detects oxygen deficiency, elevated levels of oxygen, combustible gases, carbon monoxide, and hydrogen sulfide, all of which can be dangerous or life threatening. When using the GX-3R, you must follow the instructions and warnings in this manual to assure proper and safe operation of the unit and to minimize the risk of personal injury. Be sure to maintain and periodically calibrate the GX-3R as described in this manual.

Specifications

Table 1: Standard Sensor Specifications/Alarm Points

	Combustible Gas, Methane (CH₄) Calibration Standard*	Oxygen (O₂)	Hydrogen Sulfide (H₂S)	Carbon Monoxide (CO)
Detection Range	0 - 100% LEL	0 - 40% volume	0 - 200.0 ppm	0 - 2000 ppm
Lowest Detectable Limit (LDL)	n/a	n/a	0.5 ppm	3 ppm
Reading Increment	1% LEL	0.1% volume	0.1 ppm	1 ppm
Warning Setpoint	10% LEL	19.5% volume, decreasing	5.0 ppm	25 ppm
Alarm Setpoint	25% LEL	18.0% volume, decreasing	30.0 ppm	50 ppm
Alarm H Setpoint	50% LEL	23.5% volume, increasing	100.0 ppm	1200 ppm
STEL Setpoint	n/a	n/a	5.0 ppm	200 ppm
TWA Setpoint	n/a	n/a	1.0 ppm	25 ppm

* The GX-3R is also available set up for general hydrocarbons and calibrated to a combustible gas other than methane, such as isobutane. Consult RKI Instruments, Inc. for further information.

Table 2: GX-3R Specifications

Sampling Method	Diffusion (this model does not have internal suction pumps)
Response Time	T90 within 30 seconds
Display	Graphics LCD Display
Environmental Conditions	<ul style="list-style-type: none"> • 3000 meter maximum altitude • Operating pressure: 70 - 120 kPa (70 - 110 kPa for explosion-proof) • Pollution degree 2 • IP 66/68
Operating Temperature & Humidity Ranges	<p>Continuous environment: -20°C to 50°C/Below 90% RH</p> <p>Temporary environment (up to 15 minutes): -40°C to 60°C/Below 95% RH</p> <p>Ambient temperature range (for charging): 0°C to 40°C</p> <p><i>NOTE: The H₂-compensated CO sensor may not effectively compensate for high levels of H₂ if exposed to temperatures above 40°C for longer than 15 minutes. Under these conditions, it can appear to the instrument that the H₂ concentration has exceeded 2000 ppm, the max concentration that can be compensated for, resulting in a CO reading higher than the actual CO level.</i></p>

Table 2: GX-3R Specifications



<p>Safety/ Regulatory</p>	<ul style="list-style-type: none"> • ATEX: Certificate Number: DEKRA 17ATEX0103 X IIIG Ex da ia IIC T4 Ga/IM1 Ex da ia I Ma (with combustible sensor NCR-6309) IIIG Ex ia IIC T4 Ga/IM1 Ex ia I Ma (without combustible sensor NCR-6309) • IECEx: Certificate Number: IECEx DEK 17.0050 X Ex da ia IIC T4 Ga/Ex da ia I Ma (with combustible sensor NCR-6309) Ex ia IIC T4 Ga/Ex ia I Ma (without combustible sensor NCR-6309) <div style="text-align: center;">  </div> <ul style="list-style-type: none"> • CSA classified, “C/US”, as Intrinsically Safe. Class I Division 1 Groups A, B, C, D T4. Class I, Zones 0, A/Ex da ia IIC T4 Ga (with combustible sensor NCR-6309) Class I, Zones 0, A/Ex ia IIC T4 Ga (without combustible sensor NCR-6309) <div style="text-align: center;">  C US 186718 </div> <ul style="list-style-type: none"> • Ambient Temperature Range (for intrinsically safe rating): -40°C to 60°C • Intrinsically safe construction and flame-proof enclosures <p>WARNING: The combustible gas sensor NCR-6309, to measure LEL, is the only part of this Gas Monitor system with flame-proof construction.</p>
<p>List of Standards</p>	<ul style="list-style-type: none"> • IEC 60079-0:2017 • IEC 60079-1:2014-06 • IEC 60079-11:2011 • EN IEC 60079-0:2018 • EN60079-1:2014 • EN60079-11:2012 • EN50303:2000
<p>Power Supply</p>	<p>Lithium ion battery pack (3.7 VDC, 200 mA)</p> <ul style="list-style-type: none"> • Maxell rechargeable battery model no. ICP463048XS • The battery should be charged with the dedicated AC adapter or by power from a IEC60950-certified SELV power source, or IEC62368-1-certified ES1 power source. The maximum voltage from the charger shall not exceed 6.3 VDC. <p>NOTE: The GX-3R draws power from an integrated rechargeable Li-ion battery that is not user-replaceable.</p>
<p>Continuous Operating Hours @ 25 °C</p>	<p><u>With combustible gas sensor:</u> 25 hours in Measuring Mode (non-alarm operation) <u>Without combustible gas sensor:</u> 60 hours in Measuring Mode (non-alarm operation)</p>

Table 2: GX-3R Specifications

<p>Battery Charger Ratings</p>	<p>Input: 100 - 240 VAC, 47 - 63 Hz, 2.4 A Output: 5.99 VDC, 2A max</p> <p><i>NOTE: A dedicated AC adapter is used for recharging the Li-ion battery. The battery should be charged with the dedicated AC adapter or by power from a IEC60950-certified SELV power source, or IEC62368-1-certified ES1 power source. The maximum voltage from the charger shall not exceed 6.3 VDC.</i></p> <p><i>WARNING: Do not charge the unit with a non-genuine charger.</i></p>					
<p>Case</p>	<ul style="list-style-type: none"> • High-impact Plastic, RF Shielded, Dust and Weather Proof (IP 66/68) <p><i>WARNING: The enclosures shall be protected against exposure to hydraulic liquids, oil or grease.</i></p>					
<p>Included Accessories</p>	<ul style="list-style-type: none"> • Alligator clip • Rubber boot • Wrist strap • Calibration cup • Single-unit charger 					
<p>Other Accessories</p>	<ul style="list-style-type: none"> • 12 VDC adapter • Multi-unit charger • Belt clip • SDM-3R • RP-3R • Aspirator adapter • IrDA/USB Cable for connecting to a computer when using the Data Logger Management Program (not needed if computer has an infrared port) 					
<p>Dimensions and Weight</p>	<p>Approximately 65(H) x 58(W) x 26(D) mm (2.6”H x 2.3”W x 1.0”D) Approximately 100 g (3.5 oz.)</p>					
<p>Serial Number Key</p>	Instrument No.	00	0	000	0000	00
		A	B	C	D	E
	<ul style="list-style-type: none"> • A: Year of manufacture (0 to 9) • B: Month of manufacture (1 to 9 for Jan.-Sep.; XYZ for Oct., Nov., Dec.) • C: Manufacturing lot • D: Serial number • E: Factory codes 					

About this Manual

The *GX-3R Operator's Manual* uses the following conventions for notes, cautions, and warnings.

NOTE: Describes additional or critical information.

CAUTION: *Describes potential damage to equipment.*

WARNING: *Describes potential danger that can result in injury or death.*

Chapter 2: Description

Overview

This chapter describes the GX-3R instrument and its accessories.

Instrument Description

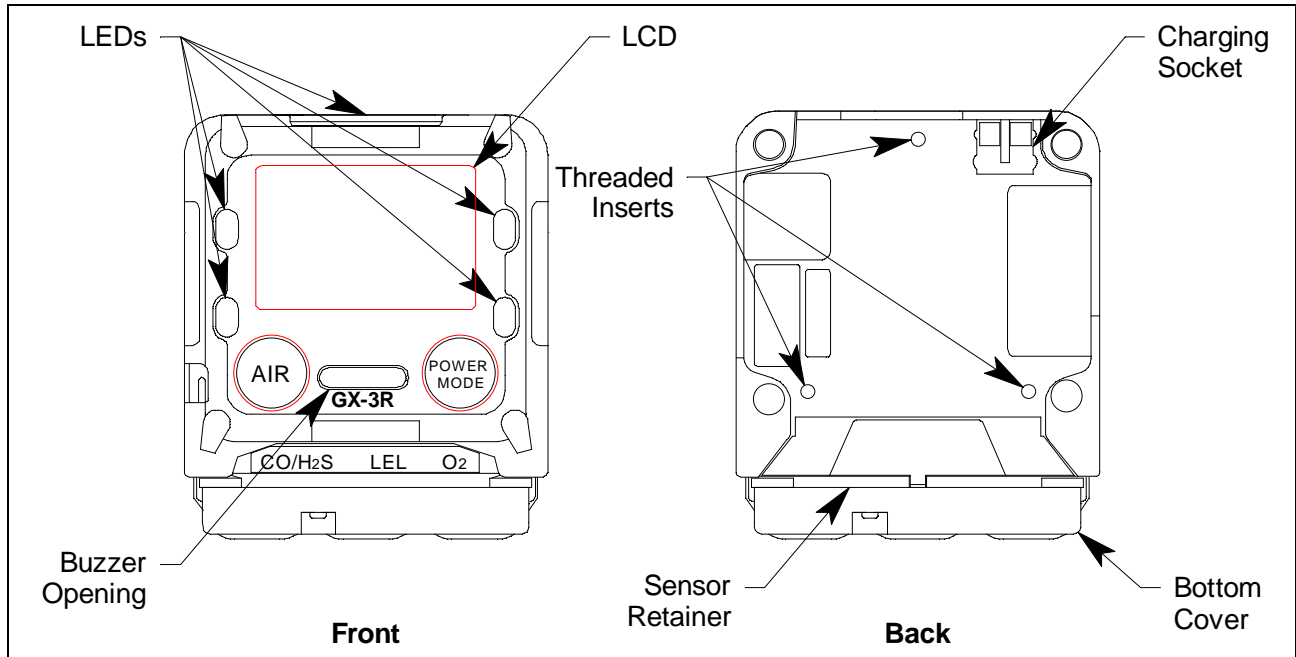

Figure 1: Component Location

Case

The GX-3R's sturdy, high-impact plastic case is radio frequency (RF) resistant and is suitable for use in many environmental conditions, indoors and out. The case is dust proof and water resistant. A clear plastic window on the front of the case allows for LCD viewing. The black bottom cover, located on the bottom of the case, allows access to the filters and sensors. A sensor retainer and filter gasket help orient and retain the sensor and filters.

Three threaded inserts on the back of the case allow for installation of an alligator clip or belt clip.

LCD

The digital LCD (liquid crystal display) simultaneously shows the gas reading for all installed sensors. The LCD also shows information for each of the GX-3R's operating modes.

WARNING: *A thin protective film covers the display to prevent scratches during shipping. Remove this film before use. Leaving the film installed voids the intrinsically safe certification.*

Control Buttons

Two control buttons, AIR and POWER MODE, are located below the LCD.

Table 3: GX-3R Control Button Functions

Button	Function(s)
AIR	<ul style="list-style-type: none">• turns on LCD backlight• resets alarm condition if LATCHING is set to ON in Maintenance Mode• enters User Mode, Maintenance Mode, and Gas Select Mode when used with POWER MODE button• activates the demand zero function (adjusts the GX-3R's fresh air reading)• changes the value of a parameter available for adjustment• scrolls through parameter options
POWER MODE	<ul style="list-style-type: none">• turns the GX-3R on and off• turns on LCD backlight• enters and scrolls through Display Mode• enters instructions into the GX-3R's microprocessor• resets alarm condition if LATCHING is set to ON in Maintenance Mode• enters User Mode, Maintenance Mode, and Gas Select Mode when used with AIR button

Alarm LEDs

The six alarm LEDs around the edge of the case alert you to gas, low battery, and failure alarms.

Buzzer

One solid-state electronic buzzer is located inside the case. Sound exits the case through a hole in the middle front of the case. The buzzer sounds for gas alarms, malfunctions, low battery voltage, and as an indicator during use of the GX-3R's many display and adjustment options.

Vibrator

A vibrating motor inside the GX-3R case vibrates for gas alarms, unit malfunctions, and as an indicator during normal use of the various modes of the GX-3R.

NOTE: If **STEALTH** is set to **ON**, the vibrator only functions when **VIB** in the **STEALTH** Gas Select Mode item is set to **ON**. See “Stealth and Vibrator Settings (STEALTH)” on page 138.

Sensors

The GX-3R uses three sensors to monitor combustible gas, oxygen (O₂), carbon monoxide (CO), and hydrogen sulfide (H₂S) simultaneously. The sensors are located inside the GX-3R and are held in their sockets by the sensor retainer and bottom cover. The sensors use different detection principles, as described below.

Combustible Gas Sensor

The combustible gas sensor (NCR-6309) detects combustible gas in the % LEL range using 2 catalytic elements: a standard element and a poison-resistant element that is resistant to sensor poisons like silicone. The element’s resistance changes based on the reaction of gas with oxygen. The change in resistance affects the current flowing through the element. The GX-3R’s circuitry amplifies the current, converts the current to a gas concentration, and displays the concentration on the LCD.

The standard calibration for the combustible gas sensor is to methane but the sensor will still detect and respond to a variety of combustible gases.

WARNING: *Do not give strong force or shock to NCR-6309. There is a danger that the flame-proof performance will be damaged due to breakage etc. This sensor uses flame-proof conditions of "low" possibility of mechanical damage.*

WARNING: *NCR-6309 must not be exposed to ultraviolet light. The sensor shall not be exposed to ultraviolet light or used in equipment in which it is not fully enclosed.*

O₂/CO/H₂S Sensors

The O₂, CO, and H₂S sensors are electrochemical cells that consist of two precious metal electrodes in a dilute acid electrolyte. A gas permeable membrane covers the sensor face and allows gas to diffuse into the electrolyte. The gas reacts in the sensor and produces a current proportional to the concentration of the target gas. The GX-3R’s circuitry amplifies the current, converts the current to a gas concentration, and displays the concentration on the LCD.

There are 4 different types of CO and H₂S sensors available:

- CO only (ESR-A13P-CO): A single electrochemical cell that detects CO. Instruments with this sensor cannot detect H₂S.

- H₂-compensated CO (ESR-A1CP-CO-H): A single electrochemical cell that detects CO. This sensor does not respond to or responds minimally to hydrogen (displays H₂ RICH once H₂ concentration reaches 2000 ppm). Instruments with this sensor cannot detect H₂S.

NOTE: The H₂-compensated CO sensor may not effectively compensate for high levels of H₂ if exposed to temperatures above 40°C for longer than 15 minutes. Under these conditions, it can appear to the instrument that the H₂ concentration has exceeded 2000 ppm, the max concentration that can be compensated for, resulting in a CO reading higher than the actual CO level.

- H₂S only (ESR-A13i-H₂S): A single electrochemical cell that detects H₂S. Instruments with this sensor cannot detect CO.
- CO/H₂S (ESR-A1DR-COHS): A combination electrochemical cell that detects both CO and H₂S.

Dummy Sensors

A dummy sensor is installed in any units that have less than 3 sensors. Dummy sensors are factory installed. The flat side of the dummy sensor faces away from the GX-3R and the hollow side faces toward the GX-3R.

Filters

Combustible Gas Sensor H₂S Removal Filter Disk (Dark Red)

An H₂S removal filter disk is placed into a recess in the filter gasket over the combustible gas sensor. The filter disk prolongs the life of the combustible gas sensor by preventing H₂S in the ambient air from reaching the sensor. The H₂S filter disk is dark red in color and although it may darken over time, its color is not indicative of remaining filter life.

The H₂S filter disk needs replacing once it's been exposed to 33 ppm hours of H₂S. This means the filter needs replacing after 80 minutes of exposure to 25 ppm H₂S which equates to 40 2-minute calibrations with a cylinder containing 25 ppm H₂S. If H₂S exists in the monitoring environment, the H₂S filter disk will have to be replaced more frequently.

CO/H₂S Sensor Dual Filter (Black and White)

A dual filter is placed into a recess in the filter gasket over the dual CO/H₂S sensor. The black half is a charcoal filter for the CO sensor. The white half is a humidity filter for the H₂S sensor.

Replace the filter if you notice the following:

- Unexplained CO readings
- For users with a 1 ppm H₂S alarm setpoint: A drift on the H₂S zero reading, unexplained H₂S readings, the filter appears dirty, or every 6 months (whichever is sooner)

CO Sensor Charcoal Filter (Black)

A black charcoal filter is placed into a recess in the filter gasket over the CO sensor. The charcoal filter disk scrubs H₂S and certain hydrocarbons out of the sample to avoid false CO readings. If false or elevated CO readings are noticed, especially in the presence of H₂S, change the charcoal filter.

H₂S Sensor Humidity Filter (White)

A white humidity filter covers the H₂S sensor. The filter absorbs humidity in the sampling environment to prevent unstable readings around 0 ppm H₂S. For users with a 1 ppm H₂S alarm setpoint, the filter should be replaced every 6 months, if you notice a drift on the zero reading, or if the filter appears dirty (whichever is sooner). For users with a 2 ppm or higher H₂S setpoint, the filter does not necessarily need to be replaced.

Hydrophobic Dust Filter

The oval-shaped hydrophobic dust filter is attached to the top of the filter gasket, covering the sensor ports and the filters. The filter gasket and hydrophobic dust filter get replaced as a set.

NOTE: Some GX-3Rs have a hydrophobic dust filter that is not attached to the filter gasket. When replacing the hydrophobic dust filter on one of these GX-3Rs, remove the filter and the gasket and replace it with a filter gasket/hydrophobic dust filter assembly.

Infrared Communications Port

An infrared (IR) communications port is located on the top of the case, near the top LEDs. Logged data transmits through the port in standard IrDA protocol. A computer's infrared port or an IrDA/USB cable connected to a USB port can be used to download data to the GX-3R Data Logger Management Program. See the GX-3R Data Logger Management Program operator's manual for data logging and downloading instructions.

Charging Socket and Battery Pack

A charging socket on the back of the instrument allows for charging cable connection.

A lithium ion (Li-ion) battery pack powers the GX-3R. At 25°C the battery lasts at least 25 hours. The battery icon in the upper right of the LCD shows remaining battery life.

A low battery warning activates when the GX-3R detects a low battery voltage. The GX-3R sounds a dead battery alarm when battery voltage is too low for Measuring Mode.

The battery pack can be recharged by using the GX-3R charging cable. The battery pack is not user-replaceable.

NOTE: Use of batteries or battery chargers not specified by RKI Instruments, Inc. will compromise the CSA classification and may void the warranty. See "Recharging the Batteries" on page 98.

WARNING: Do not charge batteries in a hazardous location. Do not charge the unit with a non-genuine charger.

AVERTISSEMENT: Ne chargez pas les batteries dans un endroit dangereux. Ne chargez pas l'appareil avec un chargeur qui n'est pas d'origine.

Included Accessories

Alligator Clip

An alligator clip is installed on the back of the GX-3R. The alligator clip can be used to attach the GX-3R to clothing or a belt. Teeth in the alligator clip's jaws prevent the unit from slipping off.

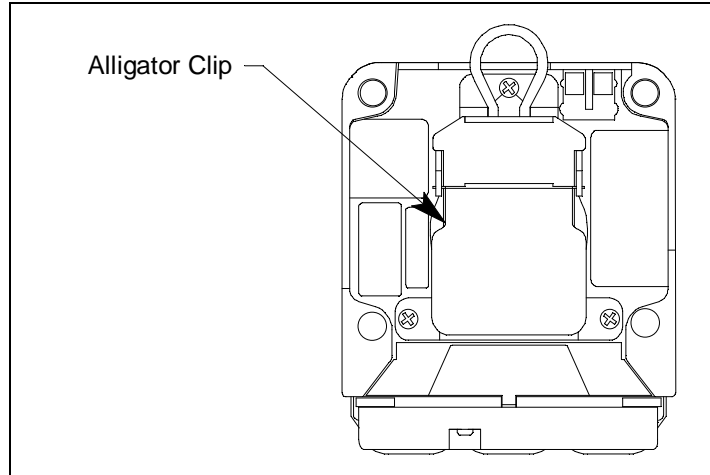

Figure 2: Alligator Clip

Rubber Boot

A black rubber boot is installed on the GX-3R.

Wrist Strap

A wrist strap is included with the GX-3R and can be attached to the wrist strap installation feature on the left side of the GX-3R's case.

Single-Unit AC Charger

The charging cable is a 4 foot cable with an AC adapter on one end and a charging plug that connects to the GX-3R on the other end.

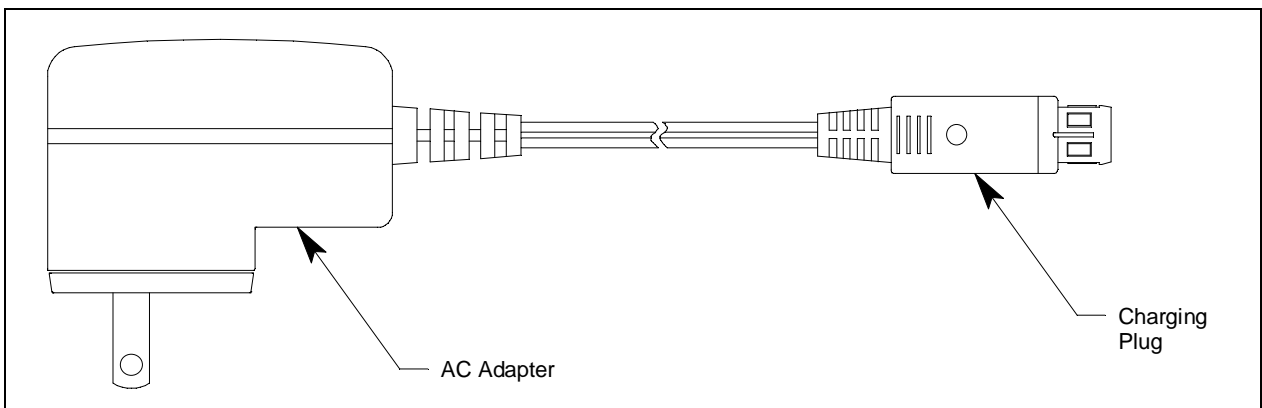

Figure 3: Charging Cable

Calibration Cup

Use the calibration cup to apply gas during a bump test, calibration, or gas test. The calibration cup has an installation orientation to observe. “Front” and “rear” imprinting on the bottom of the cup correspond to the front and rear of the GX-3R when the calibration cup is installed. In addition, a “front” label on the front of the calibration cup should be visible when viewing the LCD with the calibration cup installed.

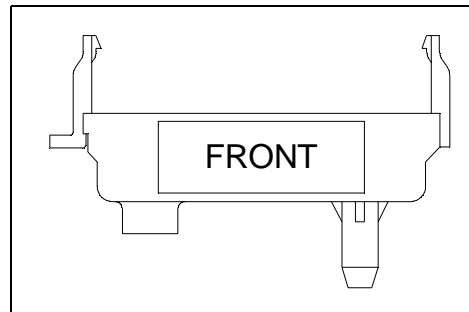

Figure 4: Calibration Cup

Other Accessories

12 VDC Charger

The 12 VDC charger is a 4 foot cable with a vehicle plug on one end and plug that connects to the GX-3R’s power jack on the other end.

Multi-Unit AC Charger

The multi-unit charger is a 4 foot wall plug style adapter that plugs into a bar. The bar has five 2-foot cables coming out one side. The end of each of the five cables has a plug that connects to the GX-3R’s power jack. The AC adapter is rated 100 - 240 VAC input, 5.99 VDC output.

Belt Clip

A belt clip makes it easy to hook the GX-3R to a utility belt.

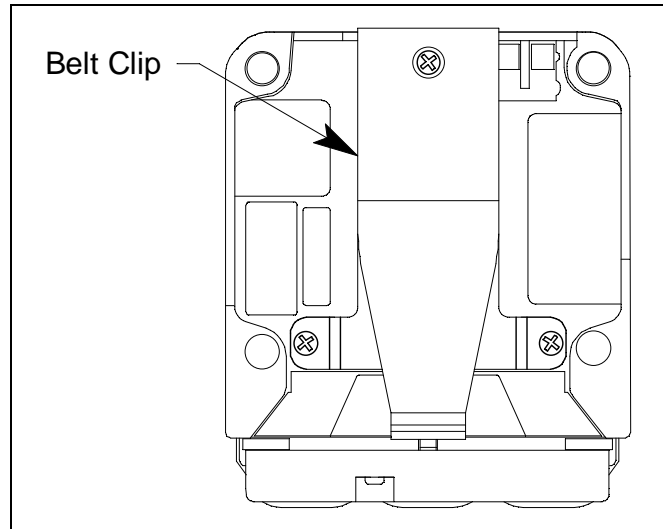

Figure 5: Belt Clip

SDM-3R

The SDM-3R is a calibration station for the GX-3R and GX-3R Pro. The station's buttons can be used for operations (Standalone Mode) or a computer can be used to control the docking station (PC Controlled Mode). See the appropriate SDM-3R manual for more information.

RP-3R

The RP-3R is a pump that draws sample to the GX-3R. See the RP-3R manual for more information.

Aspirator Adapter

The aspirator adapter is a squeeze-bulb assembly that draws sample to the GX-3R.

IrDA Cable

Unless your computer has a built-in IrDA port, an IrDA cable is needed to establish communication between the GX-3R and the Datalogging Program or the User Setup Program.

Chapter 3: Operation

Overview

This chapter explains how to use the GX-3R to perform confined space entry monitoring or general area monitoring in Measuring Mode.

Start Up

This section explains how to start up the GX-3R, get it ready for operation, and turn it off.

WARNING: *A thin protective film covers the display to prevent scratches during shipping. Remove this film before use. Leaving the film installed voids the intrinsically safe certification.*

NOTE: The screens illustrated in this section are for a standard 4-gas unit. The screens displayed by your GX-3R may be slightly different.

Turning On the GX-3R

To illustrate certain functions, the following description of the GX-3R start up sequence assumes that the following menu items in User Mode are turned on: **LUNCH**, **CAL RMDR**, and **BUMP.RMDR** in User Mode, and **ID DISP** and **AUTOZERO** in Maintenance Mode. If any of these items are turned off, then the corresponding screens will not appear.

1. Press and briefly hold down **POWER MODE**. Confirm that the LCD turns on, the LEDs flash, the buzzer sounds, and the motor vibrates before continuing with operation. Release the **POWER MODE** button when you hear a beep.
2. If **LUNCH** is set to **ON** (factory setting if **OFF**, see “Updating the Lunch Break Setting (LUNCH)” on page 89), the Lunch Break Screen appears. The unit counts down from 5 seconds.

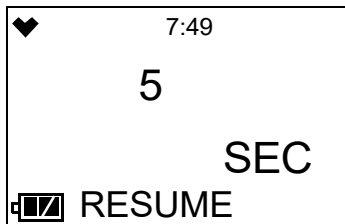

- a. Continue Accumulating: To continue accumulating peak and time-weighted average (TWA) readings from the last time the GX-3R was used, press and release **POWER MODE** or allow the countdown to reach 0. The short-term exposure limit (STEL) reading is reset each time the GX-3R is turned on.
- b. Reset Accumulation: To reset the accumulation of peak and time-weighted average (TWA) readings, press and release **AIR** before the countdown reaches 0.

3. If **CAL RMDR** is set to **ON** (factory setting) and a calibration is due, the screen that appears next depends on how **CAL EXPD** is set in User Mode (see “CAL EXPD” on page 80). The three possible screens are described below. If a calibration is not due, the instrument shows how many days are left until a calibration is due.

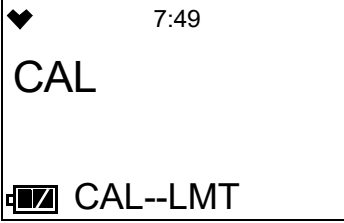
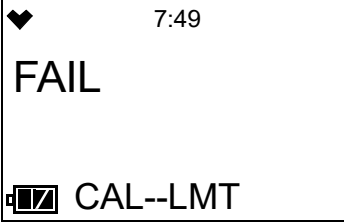
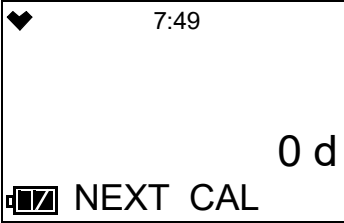
	CAL EXPD set to CONFIRM (factory setting)	CAL EXPD set to CANT USE	CAL EXPD set to NONE
LCD			
Sound	Buzzer sounds double pulsing tone	Buzzer sounds double pulsing tone	None
Action	<ul style="list-style-type: none"> • <u>Option A, Perform calibration</u>: Press and release POWER MODE to perform a calibration. The instrument takes you straight to the AUTO CAL CYL A screen in User Mode’s GAS CAL\AUTO CAL item. If Password Protection is set to On using the SDM-3R PC program, you must enter a password. See page 67 for calibration instructions. If the calibration is successful, the screen above will not appear again until the unit is due for calibration. If the calibration is not successful, the screen above will again appear in the startup sequence. • <u>Option B, Bypass message</u>: To continue without performing a calibration, press and release AIR. 	<ul style="list-style-type: none"> • The GX-3R cannot be used until a successful calibration is performed. Press and release POWER MODE to perform a calibration. The instrument takes you straight to the AUTO CAL CYL A screen in User Mode’s GAS CAL\AUTO CAL item. If Password Protection is set to On using the SDM-3R PC program, you must enter a password. If you don’t press POWER MODE, the instrument automatically goes to the AUTO CAL CYL A screen after 6 seconds. If Password Protection is set to On using the SDM-3R PC program, you must enter a password. See page 67 for calibration instructions. If the calibration is successful, the screen above will not appear again until the unit is due for calibration. If the calibration is not successful, the screen above will again appear in the startup sequence. 	<ul style="list-style-type: none"> • <u>Option A, Perform calibration</u>: To perform a calibration, press and release POWER MODE. The instrument takes you straight to the AUTO CAL CYL A screen in User Mode’s GAS CAL\AUTO CAL item. If Password Protection is set to On using the SDM-3R PC program, you must enter a password. • <u>Option B, Bypass message</u>: To continue without performing a calibration, wait a few seconds for the instrument to continue with its startup sequence.

4. If **BUMP.RMDR** is set to **ON** (factory setting is **OFF**) and a bump test is due, the screen that appears next depends on how **BUMP.EXPD** is set in User Mode (see “**BUMP.EXPD**” on page 85). The three possible screens are described below. If a bump test is not due, the instrument shows how many days are left until a bump test is due.

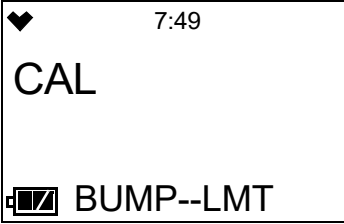
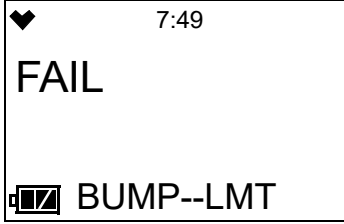
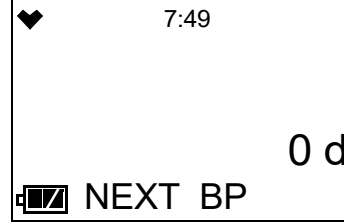
	BUMP.EXPD set to CONFIRM (factory setting)	BUMP.EXPD set to CANT USE	BUMP.EXPD set to NONE
LCD			
Sound	Buzzer sounds double pulsing tone	Buzzer sounds double pulsing tone	None
Action	<ul style="list-style-type: none"> • <u>Option A, Perform bump test:</u> Press and release POWER MODE to perform a bump test. The instrument takes you straight to the BUMP CYL A screen in User Mode’s BUMP item. If Password Protection is set to On using the SDM-3R PC program, you must enter a password. See page 60 for bump test instructions. If the bump test is successful, the screen above will not appear again until the unit is due for bump testing. If the bump test is not successful, the screen above will again appear in the startup sequence. • <u>Option B, Bypass message:</u> To continue without performing a bump test, press and release AIR. 	<p>The GX-3R cannot be used until a successful bump test has been performed. Press and release POWER MODE to perform a bump test. The instrument takes you straight to the BUMP CYL A screen in User Mode’s BUMP item. If Password Protection is set to On using the SDM-3R PC program, you must enter a password. If you don’t press POWER MODE, the instrument automatically goes to the BUMP CYL A screen after 6 seconds. If Password Protection is set to On using the SDM-3R PC program, you must enter a password. See page 60 for bump test instructions.</p> <p>If the bump test is successful, the screen above will not appear again until the unit is due for bump testing. If the bump test is not successful, the screen above will again appear in the startup sequence.</p>	<ul style="list-style-type: none"> • <u>Option A, Perform bump test:</u> To perform a bump test, press and release POWER MODE. The instrument takes you straight to the BUMP CYL A screen in User Mode’s BUMP item. If Password Protection is set to On using the SDM-3R PC program, you must enter a password. • <u>Option B, Bypass message:</u> To continue without performing a bump test, wait a few seconds for the instrument to continue with its startup sequence.

5. The Date/Time Screen appears for a few seconds.

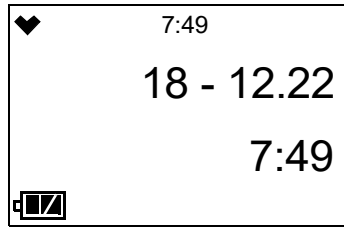

6. The Battery Voltage Screen appears for a few seconds.

An “AL-L” at the bottom of the screen indicates that the alarms are set to latching. An “AL-A” at the bottom of the screen indicates that the alarms are set to auto reset. See page 126 for a description of how to change this parameter.

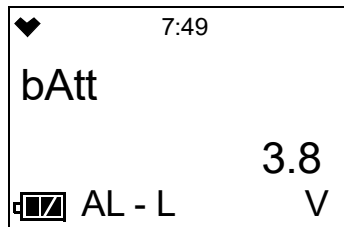

7. The combustible gas sensor contains 2 separate sensors: a standard catalytic sensor and a backup, poison-resistant sensor that is resistant to sensor poisons like silicone. An HC Gas List alarm indicates that the standard sensor has a reduced output, possibly due to one or more sensor poisons in the environment, and that the poison-resistant sensor is being used to provide gas readings. The poison-resistant sensor has a limited list of detectable gases. See Table 10 on page 48 for which gases can and cannot be detected during an HC Gas List condition.

Depending on the version, one of the following screens appears, the LEDs flash, and the instrument beeps.

Press and release POWER MODE to confirm the HC Gas List screen and continue to the Gas Name Screen. If POWER MODE is not pressed after 5 seconds, the GX-3R will automatically proceed to the next screen.

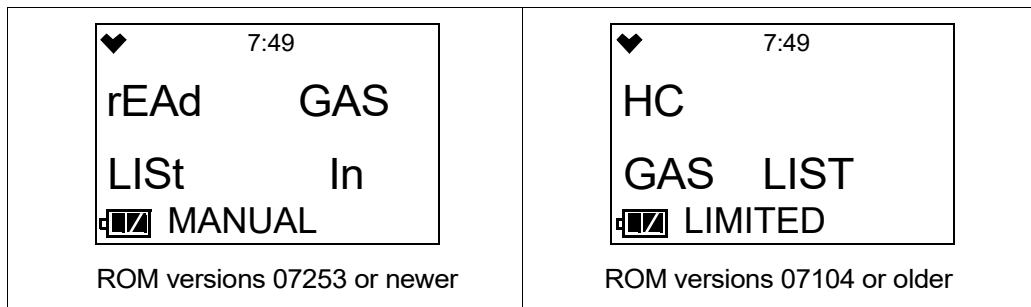

NOTE: If your application requires detection of a gas still detectable after an HC Gas List condition (like methane or isobutane), there is no need to replace the combustible gas sensor.

However, if your application requires detection of a gas not detectable after an HC Gas List condition (like methanol or ethanol), you must replace the combustible gas sensor as soon as possible.

8. The following screens display for 3 seconds each: the Gas Name Screen, the Full Scale Screen, the Warning Setpoint Screen, the Alarm Setpoint Screen, the Alarm H Setpoint Screen, the STEL Alarm Screen, and TWA Alarm Screen.
-

NOTE: If the combustible gas is set to something other than CH₄ or H₂ in Gas Select Mode, the combustible channel is displayed as “HC” and the gas formula for the combustible gas sensor’s target gas appears during startup.

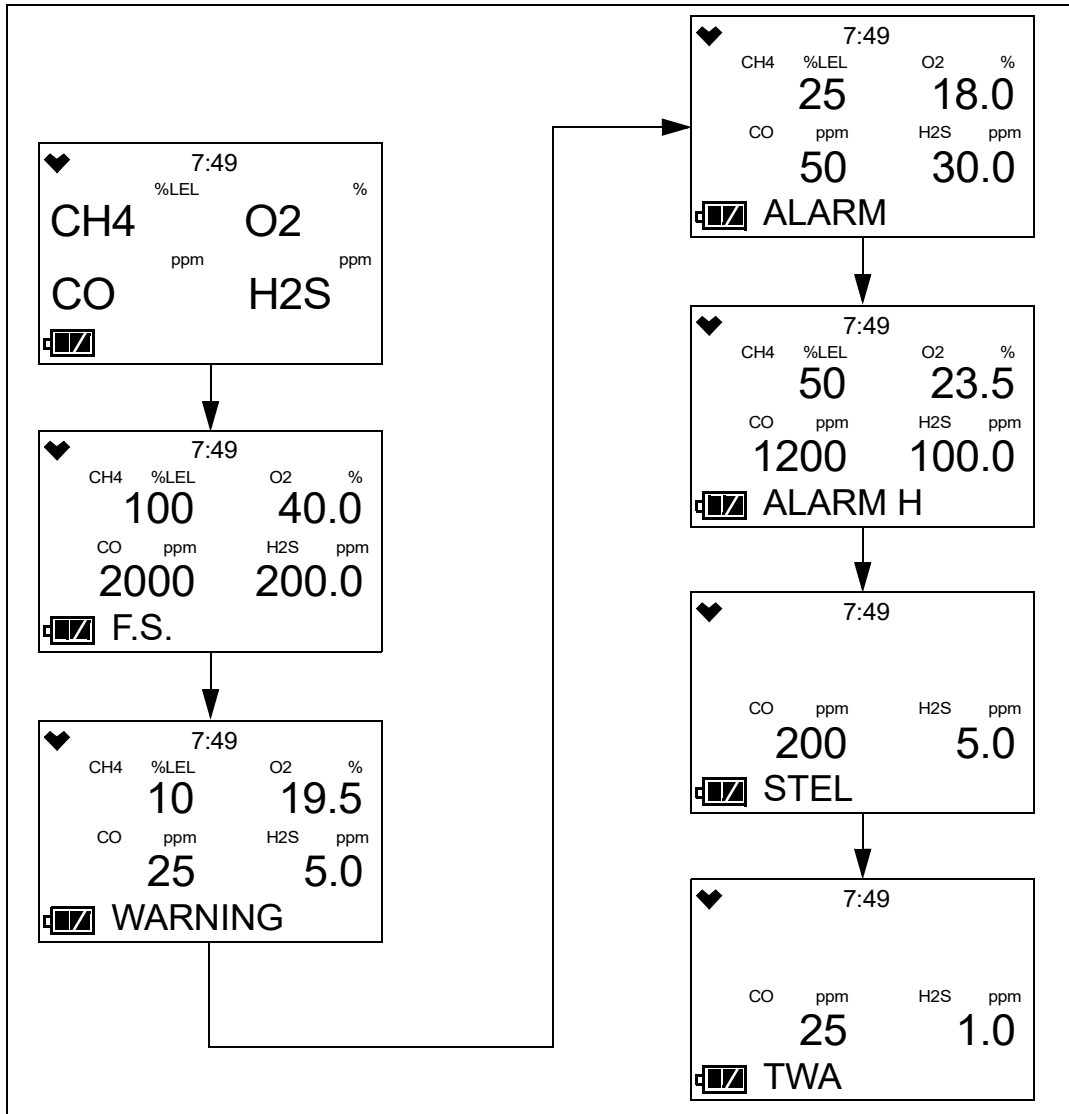

9. If **ID DISP** is set to **ON** (factory setting is **OFF**, see page 127), the User ID Screen appears for a few seconds, followed by the Station ID Screen.

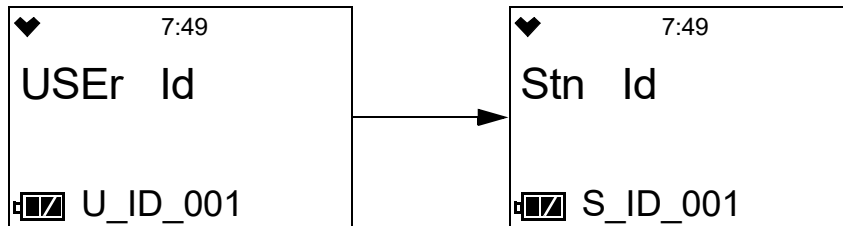

10. If the GX-3R experiences a sensor failure during start up, the display shows which sensor failed and the buzzer sounds a double pulsing tone once per second. In the example below, the combustible gas sensor failed.

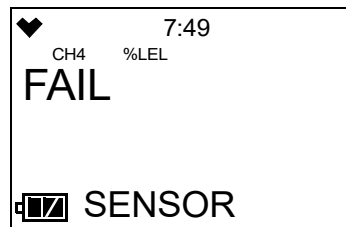

Press and release POWER MODE to acknowledge the failure and continue. “- - -” replaces the failed sensor’s gas reading. Replace the failed sensor as soon as possible.

11. If **AUTOZERO** is set to **ON** (factory setting is **OFF**, see page 127), the instrument prompts you to do an auto zero. An auto zero operation sets the combustible gas, H₂S, and CO channels to zero and the OXY channel to 20.9%.

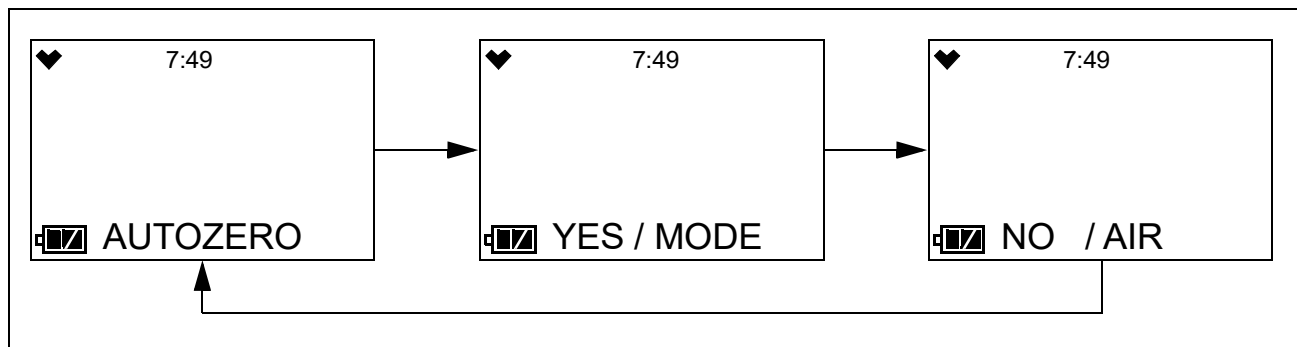

WARNING: *Make sure that the instrument is in a known fresh air environment (an environment free of combustible or toxic gases and of normal oxygen content, 20.9%) before performing an auto zero operation. If you perform an auto zero operation in an area with gases present, the adjustment will not be accurate.*

You must press and release the POWER MODE button to perform an auto zero function. If you do not press any key, after 15 seconds, the instrument enters Measuring Mode without performing an auto zero.

If **Password Protection** is turned **On** (factory setting is **Off**) using the SDM-3R PC program, a user-set password is required to perform an auto zero. When the password screen appears, adjust each digit with the AIR button and press and release the POWER MODE button to move on to the next digit. Once the password is entered, the instrument performs the auto zero.

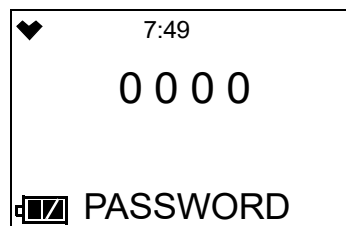

- At the end of the 45 second warmup, the GX-3R begins monitoring for gas in Measuring Mode. The Measuring Mode Screen displays the current gas reading for each target gas.

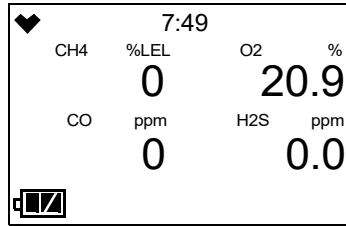

Performing a Demand Zero

Perform a demand zero before using the GX-3R. This sets the combustible gas, H₂S, and CO channels to zero and the OXY channel to 20.9%.

- Find a fresh-air environment. This is an environment free of toxic or combustible gases and of normal oxygen content (20.9%).
- Turn on the unit as described above in Turning On the GX-3R.
- Press and hold AIR. The LCD prompts you to continue holding AIR and the buzzer pulses while you hold the button (if **KEY TONE** is set to **ON** in User Mode).
- Continue to hold AIR until the LCD prompts you to release it. The GX-3R sets the fresh air reading for all channels. Start up is complete and the unit is now ready for monitoring.
- If **Password Protection** is turned **On** (factory setting is **Off**) using the SDM-3R PC program, a user-set password is required to perform a demand zero. When the password screen appears, adjust each digit with the AIR button and press and release the POWER MODE button to move on to the next digit. Once the password is entered, the instrument performs the demand zero.

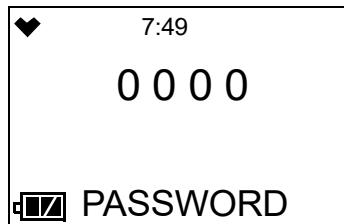

Turning Off the GX-3R

- Press and hold POWER MODE.
- TURN OFF appears on the display and the buzzer pulses for about five seconds (if **KEY TONE** is set to **ON** in User Mode).
- Release the button when TURN OFF disappears from the display.

- If **Password Protection** is turned **On** (factory setting is **Off**) using the SDM-3R PC program, a user-set password is required to turn off the GX-3R. When the password screen appears, adjust each digit with the AIR button and press and release the POWER MODE button to move on to the next digit. Once the password is entered, the instrument shuts off.

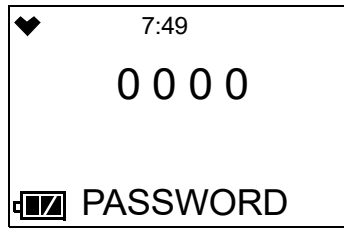

- If you plan to leave the instrument off for an extended period of time, see page 114.

Measuring Mode Operation

When the GX-3R completes its startup sequence, it is in Measuring Mode. In Measuring Mode the GX-3R continuously monitors the sampled atmosphere and displays the target gas concentrations. The GX-3R is considered to be in Normal Operation if there are no alarm indications.

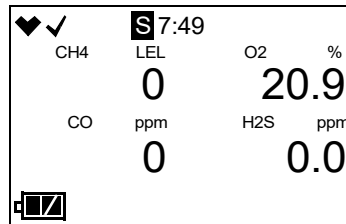

Heart Symbol: The heart symbol in the upper left corner of the LCD indicates the operation status and blinks when normal. A microprocessor error causes the heart symbol to stop flashing or to disappear.

Check Mark: If **BUMP.RMDR** is set to **ON** and if a bump test is not due, a check mark appears in the upper left corner of the LCD.

“S”: If the instrument is operating in Stealth Mode, an “S” appears at the top of the LCD.

Backlight: In a low-light environment, press and release either button to turn on the display backlight. See page 92 to program backlight duration.

Confirmation/Non-Compliance Indicator: If the **BEEP** menu item in User Mode is set to anything other than **OFF**, the GX-3R gives periodic indications to confirm that it’s operating or to indicate a non-compliance (page 90).

Monitoring an Area

1. Start up the GX-3R as described above in “Start Up” on page 23. It is now in Measuring Mode.

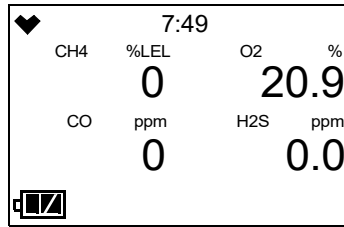

2. Take the GX-3R to the monitoring area.
3. Wait at least 15 seconds and observe the display for gas readings. If a reading is observed, allow the reading to stabilize to determine the gas concentrations present.
If you are sampling with an aspirator adapter, see page 36.
4. If a gas alarm occurs, take appropriate action. See page 40.
5. Do not expose the GX-3R to rain.
6. The GX-3R’s IP 66/68 ratings do not imply that the GX-3R will detect gas during and after exposure to those conditions. If exposure occurs, dry the instrument with a cloth and perform a bump test as described on page 60.
7. If the GX-3R gets exposed to flammable liquids:
 - a. Wipe the instrument off with a cloth dampened with water.
 - b. Replace the filters as described on page 101 and page 104 if they become saturated.
 - c. Perform a bump test as described on page 60.
8. If you suspect that the GX-3R is not operating correctly:
 - a. Take the GX-3R to a fresh air environment and perform a demand zero as described on page 30.
 - b. Perform a bump test as described on page 60.

Combustible Gas Detection

There are three issues to keep in mind when monitoring for combustible gas.

Response

The combustible gas sensor responds to any combustible gas. The standard calibrated target gas for the combustible gas channel is methane (CH₄). If the instrument is setup for and calibrated to a different combustible gas, such as hexane or propane, the gas name right above the readings displays as “HC”.

- **Automatic Conversion**

The GX-3R can automatically display converted target gas readings if the instrument’s calibrated target gas is methane or isobutane. See “Combustible Sensor Target Gas Conversion (LIST)” on page 48.

- **Manual Conversion**

You can manually calculate a converted target gas reading using Table 4 if the instrument's calibrated target gas is methane. The table lists the conversion factors for several hydrocarbon gases **if the GX-3R is calibrated to methane.**

To use this table, multiply the display reading on the combustible gas channel by the factor in the appropriate row to obtain the actual gas concentration. For example, if you are detecting ethylene and the display reads 10% LEL for the combustible gas channel, you actually have $10\% \text{ LEL} \times 0.83 = 8.3\% \text{ LEL}$ ethylene present.

Table 4: LEL Hydrocarbon Conversion Factors

Gas	LEL Conversion Factor (from CH ₄ Cal.)
Acetone	2.22
Acetylene	1.43
Benzene	2.50
Butadiene	1.52
Cyclopentane	1.45
DME	1.16
Ethane	0.94
Ethanol	1.96
Ethyl Acetate	2.86
Ethylene	0.83
Heptane	3.13
Hexane	1.89
Hydrogen	0.95

Gas	LEL Conversion Factor (from CH ₄ Cal.)
IPA	1.64
Isobutane	1.10
MEK	2.63
Methane	1.00
Methanol	1.82
MIBK	4.00
MMA	3.33
Nonane	9.09
Propane	1.12
Propylene	0.97
THF	2.33
Toluene	4.55
Xylene	7.69

Overscale Protection

The GX-3R protects the combustible gas sensor by temporarily turning off the sensor power if levels exceeding 100% LEL are detected. Nevertheless, combustible gas concentrations above 100% LEL can still affect the zero level or calibration of the combustible gas sensor.

CAUTION: *Do not expose the combustible gas sensor to high concentrations of combustible gas such as that from a butane lighter. Exposure to high concentrations of combustible gas may adversely affect the performance of the sensor.*

CAUTION: *Any rapid increase in the combustible gas reading on the combustible gas channel followed by a declining or erratic reading may indicate a gas concentration above the LEL which may be hazardous.*

Damaging Gases

Some gases such as silicone vapors, chlorinated hydrocarbons, and sulphur compounds can contaminate the sensor's detection elements. This causes sensor damage and/or a reduced response to combustible gas. Make every effort to avoid these gases.

The H₂S scrubber disks protect the combustible sensor from H₂S, but you should avoid other sulphur compounds.

HC Gas List Alarm

An HC Gas List alarm can occur at startup or after a calibration.

The combustible gas sensor actually contains 2 separate sensors: a standard catalytic sensor and a backup, poison-resistant sensor that is resistant to sensor poisons like silicone. An HC Gas List alarm indicates that the standard sensor has a reduced output, possibly due to one or more sensor poisons in the environment, and that the poison-resistant sensor is being used to provide gas readings. The poison-resistant sensor has a limited list of detectable gases. The table shown on page 48 shows which gases can and cannot be detected after receiving an HC Gas List alarm.

If your application requires detection of a gas still detectable after an HC Gas List condition (like methane or isobutane), there is no need to replace the combustible gas sensor.

However, if your application requires detection of a gas not detectable after an HC Gas List condition (like methanol or ethanol), you must replace the combustible gas sensor as soon as possible.

Oxygen-Enriched Atmospheres

The GX-3R is not intended for use in oxygen-enriched atmospheres.

WARNING: *Do not use the GX-3R in an environment whose oxygen concentration is above 21%.*

H₂-Compensated CO Detection

- GX-3R displays CO readings.
- H₂ reading is not displayed but “H₂ RICH” appears once H₂ concentration rises above 2000 ppm.

NOTE: The H₂-compensated CO sensor may not effectively compensate for high levels of H₂ if exposed to temperatures above 40°C for longer than 15 minutes. Under these conditions, it can appear to the instrument that the H₂ concentration has exceeded 2000 ppm, the max concentration that can be compensated for, resulting in a CO reading higher than the actual CO level.

Interference Information

Some gases interfere with CO and H₂S sensors. For a complete list of these gases, see page 142.

Aspirator Adapter Sampling

The aspirator adapter accessory is used when it is necessary to draw sample from an area that cannot be entered or that must be checked for safety before entry, such as a tank or confined space.

NOTE: The CSA combustable performance certification for the GX-3R does not include the aspirator adapter.

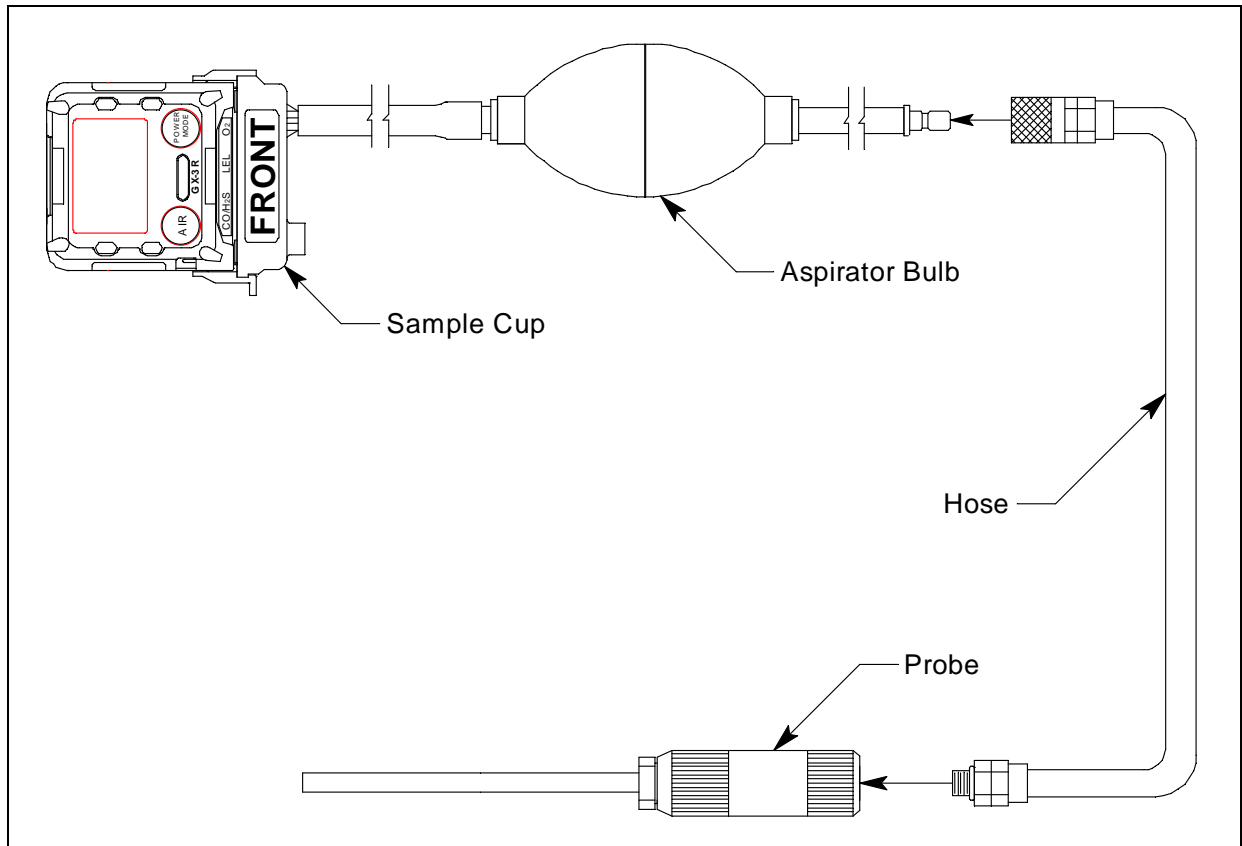

Figure 6: GX-3R Aspirator Adapter

1. Turn on the GX-3R as described on page 23.
2. Attach the sample cup to the GX-3R. Use the label and imprinting to make sure that the sample cup gets installed in the correct orientation relative to the GX-3R. Be sure the sample cup is pushed on all the way.
3. Screw the probe onto the threaded end of the hose.
4. Attached the hose and probe to the aspirator bulb.
5. Insert the end of the probe into the area to be sampled.
6. Squeeze and release the aspirator bulb 15 times.

7. Monitor the readings and note if any alarms occur. The readings will peak shortly after the last squeeze and may decrease before all the channels can be checked. Use the Peak screen in Display Mode to see the maximum readings for each channel (see page 46).

NOTE: The peak readings for each channel are saved until a higher peak is recorded, the peak readings are reset, or the instrument is turned off. If a gas is present but the level does not exceed the previous peak level, the previous peak will be displayed on the Peak Screen.

Alarms

This section covers alarm indications in Measuring Mode. It also describes responding to and resetting an alarm condition.

NOTE: False alarms may be caused by radio frequency (RF) or electromagnetic (EMI) interference. Keep the GX-3R away from RF and EMI sources such as radio transmitters or large motors.

Alarm Indications

The GX-3R buzzer sounds an alarm, the LEDs flash, and the vibrator pulses when any sort of alarm condition or failure occurs. If the GX-3R is operating in Stealth Mode, the buzzer does not sound and the vibrator's operation depend on the **VIB** setting in Gas Select Mode's **STEALTH** menu item. See page 138 for more information.

NOTE: If an alarm condition occurs while you are in Display Mode, the GX-3R automatically returns to the Measuring Mode screen.

Table 5 summarizes the types of alarms produced by the GX-3R and their indications.

Table 5: Alarm Types and Indications

Alarm Type	Visual Indications	Other Indications
<u>Warning</u> Concentration of gas rises above the Warning setting or falls below the Warning setting for O ₂ .	<ul style="list-style-type: none"> • Affected channel's gas reading, gas name, and units flash • WARNING appears at the bottom of the LCD • Alarm LEDs flash in circle sequence once per second • Backlight turns on 	<ul style="list-style-type: none"> • High-low tone sounding once per second • Vibrator pulses once per second

Table 5: Alarm Types and Indications

Alarm Type	Visual Indications	Other Indications
<p><u>Alarm</u> Concentration of gas rises above the Alarm setting or falls below the Alarm setting for O₂.</p>	<ul style="list-style-type: none"> • Affected channel's gas reading, gas name, and units flash • ALARM appears at the bottom of the LCD • Alarm LEDs flash in circle sequence twice per second • Backlight turns on 	<ul style="list-style-type: none"> • High-low tone sounding twice per second • Vibrator pulses twice per second
<p><u>Alarm H</u> Concentration of gas rises above the Alarm H setting.</p>	<ul style="list-style-type: none"> • Affected channel's gas reading, gas name, and units flash • ALARM H appears at the bottom of the LCD • Alarm LEDs flash in circle sequence twice per second • Backlight turns on 	<ul style="list-style-type: none"> • High-low tone sounding twice per second • Vibrator pulses twice per second
<p><u>TWA or STEL</u> Concentration of CO or H₂S rises above the TWA or STEL alarm setting.</p>	<ul style="list-style-type: none"> • Affected channel's gas reading, gas name, and units flash • TWA or STEL appears at the bottom of the LCD • Alarm LEDs flash in circle sequence once per second • Backlight turns on 	<ul style="list-style-type: none"> • High-low tone sounding once per second • Vibrator pulses once per second
<p><u>H₂ RICH (for GX-3Rs with H₂-compensated CO sensor)</u> Concentration of hydrogen rises above 2000 ppm (parts per million).</p>	<ul style="list-style-type: none"> • H₂ and rich alternate in the lower right corner • Alarm LEDs flash twice per second • Backlight turns on 	<ul style="list-style-type: none"> • High-low tone sounding twice per second • Vibrator pulses twice per second
<p><u>Over Range</u></p>	<ul style="list-style-type: none"> • Affected channel's gas reading is replaced with a flashing □□□ • Gas name and units flash • OVER appears at the bottom of the LCD • Alarm LEDs flash in circle sequence twice per second • Backlight turns on 	<ul style="list-style-type: none"> • High-low tone sounding twice per second • Vibrator pulses twice per second

Table 5: Alarm Types and Indications

Alarm Type	Visual Indications	Other Indications
<u>Minus Over Range</u>	<ul style="list-style-type: none"> Affected channel's gas reading is replaced with a flashing □□□ Gas name and units flash M OVER appears at the bottom of the LCD Alarm LEDs flash in circle sequence twice per second Backlight turns on 	<ul style="list-style-type: none"> High-low tone sounding twice per second Vibrator pulses twice per second
<u>Low Battery Warning</u>	<ul style="list-style-type: none"> The last bar in the battery icon starts flashing 	None
<u>Dead Battery Alarm</u>	<ul style="list-style-type: none"> Gas readings disappear. FAIL appears in the middle of the screen and BATTERY appears at the bottom of the screen. Alarm LEDs flash once per second 	Double pulsing tone once per second
<u>Sensor Failure</u>	<ul style="list-style-type: none"> SENSOR appears at the bottom of the screen and the failed sensor(s) are indicated with FAIL under the gas name. Alarm LEDs flash once per second 	Double pulsing tone once per second
<u>HC Gas List</u>	<ul style="list-style-type: none"> For GX-3Rs with ROM version 07104 or older, HC GAS LIST LIMITED appears on the screen. For GX-3Rs with ROM version 07253 or newer, READ GAS LIST IN MANUAL appears on the screen. Alarm LEDs flash once per second 	Double pulsing tone once per second
<u>Clock Failure</u>	<ul style="list-style-type: none"> FAIL appears in the middle of the screen and CLOCK appears at the bottom of the screen. Alarm LEDs flash once per second 	Double pulsing tone once per second
<u>System Failure</u>	<ul style="list-style-type: none"> FAIL SYSTEM appears at the bottom of the screen and an error code displays in the middle Alarm LEDs flash once per second 	Double pulsing tone once per second

Responding to Alarms

This section describes response to gas, over range, battery, sensor failure, HC Gas List, clock failure, and system failure alarms.

Responding to Gas Alarms

1. Determine which gas alarm has been activated.
2. Follow your established procedure for an increasing gas condition or a decreasing oxygen condition.
3. Reset the alarm as necessary or allowed (buzzer silence is available for instruments with ROM 07104 or newer).

Buzzer Silence

Buzzer silence is available for instruments with ROM version 07104 or newer.

This feature can be turned on or off using the SDM-3R PC Controller program or the GX-3R Datalogging Program.

Table 6 summarizes resetting and silencing alarms for all LATCHING and SILENCE setting combinations.

Table 6: Resetting and Silencing Alarms

	LATCHING: ON (factory setting)	LATCHING: OFF
BUZZER SILENCE: ON	<ul style="list-style-type: none"> • Press and release the POWER MODE or AIR buttons to silence the buzzer. • If the gas concentration was still above the alarm level when the button was pressed, the LED arrays continue to flash, the vibrator continues to pulse, and the GX-3R continues to display the current alarm level. • The gas reading must fall below (or rise above for an oxygen low alarm) an alarm setting before you can reset the alarm, the LEDs, and the vibrator using the POWER MODE or AIR buttons. <p><i>NOTE: If Password Protection is ON (factory setting: OFF) using the SDM-3R PC program, you must press POWER MODE <u>and</u> AIR simultaneously and then enter the user-set password to reset an alarm condition.</i></p>	<ul style="list-style-type: none"> • Press and release the POWER MODE or AIR buttons to silence the buzzer. • The POWER MODE or AIR buttons will not reset the alarm. • The alarm, LEDs, and vibrator will automatically reset when gas reading falls below (or rises above for an oxygen low alarm) an alarm setpoint.

Table 6: Resetting and Silencing Alarms

<p><u>BUZZER SILENCE: OFF</u> (<u>factory setting</u>)</p>	<ul style="list-style-type: none"> • Pressing POWER MODE or AIR will not silence buzzer. • The gas reading must fall below (or rise above for an oxygen low alarm) an alarm setting before you can reset the alarm condition using the POWER MODE or AIR buttons. 	<ul style="list-style-type: none"> • Pressing POWER MODE or AIR will not silence buzzer. • The alarm condition will automatically reset when the gas reading falls below (or rises above for an oxygen low alarm) an alarm setpoint.
---	---	--

Responding to an H2 RICH Alarm (H₂-Compensated CO Sensor Only)

The H2 RICH alarm automatically clears once the hydrogen level decreases below 2000 ppm (parts per million).

Responding to Over Range Alarms

WARNING: *An over range condition may indicate an extreme combustible gas, toxic gas, or oxygen concentration. Confirm the gas concentration with a different GX-3R or with another gas detecting device.*

CAUTION: *High off-scale readings may indicate an explosive concentration.*

PRUDENCE: *Des lectures élevées hors échelle peuvent indiquer une concentration explosive.*

1. Determine which channel is in alarm.
2. Follow your established procedure for an extreme gas condition.
3. If **LATCHING** is set to **ON** (factory setting) in Maintenance Mode, reset the alarm using POWER MODE or AIR once the alarm condition clears.

If **Password Protection** is turned **On** (factory setting is **Off**) using the SDM-3R PC program, you must press POWER MODE and AIR at the same time and then enter a user-set password to reset an alarm condition. When the password screen appears, adjust each digit with the AIR button and press and release the POWER MODE button to move on to the next digit. Once the password is entered, the alarm condition resets.

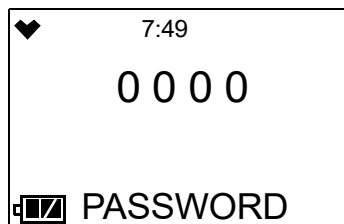

4. Calibrate the GX-3R as described on page 55.
5. If the over range condition continues or if you are not able to successfully calibrate the unit, you may need to replace the sensor that has triggered the over range alarm.

6. If the over range condition continues after you have replaced the sensor, contact RKI Instruments, Inc. for further instructions.

Responding to Battery Alarms

WARNING: *The GX-3R is not operational as a gas monitoring device during a dead battery alarm. Take the Model GX-3R to a non-hazardous area and replace or recharge the batteries as described in “Recharging the Batteries” on page 98.*

The GX-3R is fully functional during a low battery warning. However, only 1-2 hours of operating time remain. The amount of operating time left depends on LCD backlight use and the alarm frequency. Recharge the battery as soon as possible as described in “Recharging the Batteries” on page 98.

NOTE: Alarms and the LCD back light consume battery power and reduce the amount of operating time remaining.

Responding to Sensor Failure Alarms

1. Determine which sensor triggered the sensor failure alarm.
2. Calibrate the failed sensor, as described on page 55.
3. If the sensor failure continues or if the sensor could not be calibrated, replace the sensor as described on page 107.
4. If the sensor failure condition continues after you have replaced the sensor, contact RKI Instruments, Inc. for further instructions.

Responding to an HC Gas List Alarm

An HC Gas List alarm can occur at startup or after a calibration.

1. Press and release POWER MODE to acknowledge the alarm.

The combustible gas sensor actually contains 2 separate sensors: a standard catalytic sensor and a backup, poison-resistant sensor that is resistant to sensor poisons like silicone. An HC Gas List alarm indicates that the standard sensor has a reduced output, possibly due to one or more sensor poisons in the environment, and that the poison-resistant sensor is being used to provide gas readings. The poison-resistant sensor has a limited list of detectable gases. Table 10 on page 48 shows which gases can and cannot be detected after receiving an HC Gas List alarm.

If your application requires detection of a gas still detectable after an HC Gas List condition (like methane or isobutane), there is no need to replace the combustible gas sensor.

However, if your application requires detection of a gas not detectable after an HC Gas List condition (like methanol or ethanol), you must replace the combustible gas sensor as soon as possible.

Responding to Clock Failure Alarms

A clock failure alarm occurs if the unit's internal clock malfunctions. A clock failure alarm might also occur if the battery becomes too drained during storage. See page 114 for storage information.

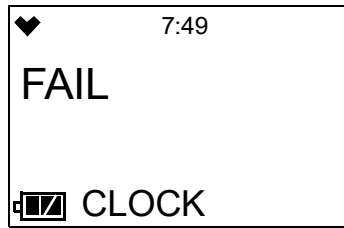

1. Press and release POWER MODE to continue into Measuring Mode.

CAUTION: *If you operate the instrument after a clock failure, data will still be logged but the date/time will be incorrect. Set the date/time as described on page 94 as soon as possible to ensure logged data uses the correct date/time.*

2. Attempt to set the date using the **DATE** menu item in User Mode. See page 94.
3. If the date cannot be set correctly, contact RKI Instruments, Inc. as soon as possible.

Responding to System Failure Alarms

1. If a system failure occurs, the system failure screen displays an error code as shown below:

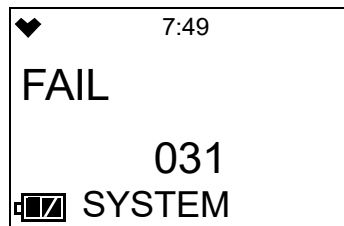

2. The error code meanings are shown in Table 7:

Table 7: Error Code Explanation

Error Code	Explanation
000	ROM failure
010	RAM failure
021	FRAM failure
031	FLASH memory failure
080	Acceleration sensor failure
081	PCB failure
082	Temperature sensor failure

3. If the error code is anything but 031 as shown above, the instrument cannot be used. Contact RKI Instruments, Inc. as soon as possible.

If the error code is 031, you may press and release POWER MODE to continue into Measuring Mode if the instrument must be used temporarily.

CAUTION: *There will be no datalogging function if you operate the instrument after a 031 system failure. Contact RKI Instruments, Inc. as soon as possible.*

Data Logging

The GX-3R logs Measuring Mode gas readings, alarm data, and calibration data to its internal memory. Logged data can be download it to a computer via the infrared communications port on the front of the unit.

To utilize the GX-3R's downloading capability, you will need the GX-3R Data Logger Management Program and a computer with an infrared port or a USB port that runs one of the following operating systems: Windows 7, Windows 8, Windows 10, or Windows 11. If your computer has an infrared port, then no additional accessories are needed to download data from the GX-3R. If your computer does not have an infrared port but does have a USB port, a USB/IrDA adapter cable can be used to download data from the GX-3R. The GX-3R Data Logger Management Program is available at www.rkiinstruments.com/gx3r. The USB/IrDA adapter cable is available from RKI Instruments, Inc.

The data logging capacity depends on how often the GX-3R stores data, how many channels are active, and how often the GX-3R is turned on and off. Table 8 illustrates how much data logging time is available for the various interval times. It assumes that the unit has three sensors, is only turned on once, and there are no alarm occurrences. The data logging interval time must be set using the GX-3R Data Logger Management Program.

Table 8: Data Logging Capacity

Interval Time	Data Logging Time
10 seconds	10 hours
20 seconds	20 hours
30 seconds	30 hours
1 minute	60 hours
3 minutes	180 hours
5 minutes (factory setting)	300 hours
10 minutes	600 hours

For a complete description of the Data Logger Management Program and procedures for downloading data to a computer, see the GX-3R Data Logger Management Program Operator's Manual.

Chapter 4: Display Mode

This section describes Display Mode which is accessible from Measuring Mode. See Table 9 for a list of Display Mode's menu items, a short description of each item, and the page number for further description.

Table 9: Display Mode Menu Items

Display Mode Menu Item	Description
PEAK (page 46)	Displays each sensor's Peak reading.
STEL (page 47)	Displays the STEL readings (CO and H ₂ S only).
TWA (page 47)	Displays the TWA readings (CO and H ₂ S only).
LIST (page 48) ^A	Change the target gas for the catalytic sensor. <ul style="list-style-type: none"> • CH₄ (methane) • i-C₄H₁₀ (isobutane) • H₂ (hydrogen) • CH₃OH (methanol) • C₂H₂ (acetylene) • C₂H₄ (ethylene) • C₂H₆ (ethane) • C₂H₅OH (ethanol) • C₃H₆ (propylene) • C₃H₆O (acetone) • C₃H₈ (propane) • C₄H₆ (butyne) • C₅H₁₀ (cyclopentane) • C₆H₆ (benzene) • n-C₆H₁₄ (hexane) • C₇H₈ (toluene) • n-C₇H₁₆ (heptane) • C₈H₁₀ (xylene) • n-C₉H₂₀ (nonane) • EtAc (ethyl acetate) • IPA (isopropyl alcohol) • MEK (methyl ethyl ketone) • MMA (methyl methacrylate) • DME (dimethyl ether) • MIBK (methyl isobutyl ketone) • THF (tetrahydrofuran) • n-C₅H₁₂ (n-pentane)
USER ID (page 50) ^B	View and/or change the User ID.
STN ID (page 51) ^B	View and/or change the Station ID.
CAL DATA (page 52) ^C	Displays each sensor's last calibration date.
BUMP DATA (page 53) ^D	Displays each sensor's last bump test date.
TEMP (page 53)	Displays the current date, time, and temperature.
ALARM--PT (page 54)	View alarm points
<p>^A Only appears if DISP SET is set to ON in User Mode (factory setting) and if CH₄ or i-C₄H₁₀ is selected for the combustible gas in Gas Select Mode.</p> <p>^B Only appears if DISP SET is set to ON in User Mode (factory setting) <u>and</u> if ID DISP is set to ON in Maintenance Mode (factory setting is OFF).</p> <p>^C Only appears if CAL RMDR is set to ON in User Mode (factory setting).</p> <p>^D Only appears if BUMP.RMDR is set to ON in User Mode (factory setting is OFF).</p>	

Tips for Using Display Mode

- To enter Display Mode and scroll from one menu item to the next or skip an item when a question is asked, press and release POWER MODE.
- To enter an item, press and release AIR.
- To change a flashing parameter, press and release AIR. To reverse the direction of movement in a list (ie. from down to up or vice versa):
 - a. Press and hold AIR.
 - b. Immediately press POWER MODE and then release both buttons.
- To exit from an entered-information screen and go back to the main menu, press and release POWER MODE.

NOTE: Each screen displays for 20 seconds. If you do not press a button within 20 seconds, the GX-3R automatically returns to Measuring Mode.

Peak Screen (PEAK)

The peak screen displays the highest (lowest for oxygen) concentrations detected since the GX-3R was turned on. Peak readings are stored in the GX-3R's memory until a higher level is detected (lower for oxygen), the peak reading is cleared, or the GX-3R is turned off.

The lunch break feature enables the GX-3R to save peak readings when it is turned off so it can continue with the same peaks when it is turned on again. See page 89 for instructions to turn the lunch break feature on (default is off).

To clear the peak readings, do the following:

NOTE: If **Password Protection** is set to **On** using the SDM-3R PC program, the peak reading cannot be cleared.

1. After entering Display Mode, press and release POWER MODE until **PEAK** appears.

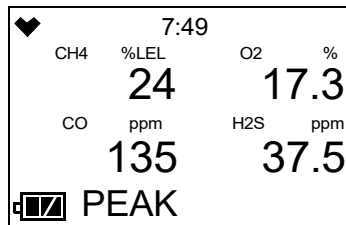

2. Press and hold AIR until the screen prompts you to release it.

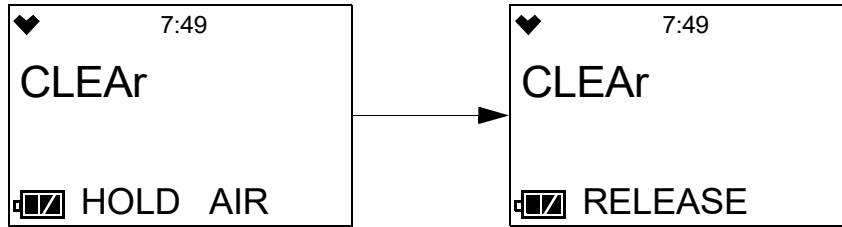

3. The peak readings are reset and the unit returns to the Peak Screen.
If you do not want to clear the peak readings, release AIR before the above screen sequence occurs. The unit returns to the Peak Screen.

STEL Screen (STEL)

The STEL Screen displays the short term exposure limit (STEL) readings *for H₂S and CO only*. The STEL reading is the average reading *over the last 15 minutes*.

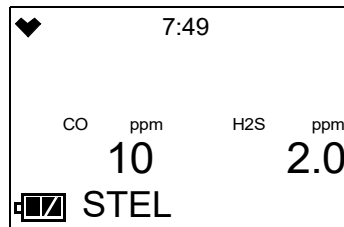

TWA Screen (TWA)

The TWA Screen displays the time weighted average (TWA) readings *for H₂S and CO only*.

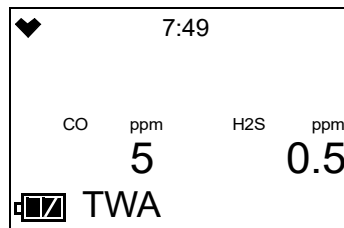

The TWA reading is the average reading *over the last 8 hours*. If 8 hours have not elapsed since the last time the TWA reading was cleared, the average is still calculated over 8 hours. The missing readings are assigned a 0 value. If **LUNCH** is set to **OFF** (factory setting), the TWA is cleared when the GX-3R is turned off.

If **LUNCH** is set to **ON**, the GX-3R remembers TWA readings when it is turned off so it can continue them when it is turned on again. See page 89 for instructions to turn the lunch break feature on (default is off).

Combustible Sensor Target Gas Conversion (LIST)

NOTE: This screen only appears if **DISP SET** in User Mode is set to **ON** (factory setting) and if the instrument's calibrated target gas is CH₄ or iC₄H₁₀ (select target gas in Gas Select Mode's **GAS COMB** item, calibrate with target gas in User Mode's **GAS CAL** item).

The **LIST** screen allows you to select a converted target gas based on a CH₄ or iC₄H₁₀ calibration. It does not change the calibrated target gas. You must go to Gas Select Mode's **GAS COMB** item to change the calibrated target gas.

Selecting a converted target gas in **LIST** (based on a CH₄ or iC₄H₁₀ calibration) does not provide the same reading accuracy as selecting a calibrated target gas in Gas Select Mode's **GAS COMB** item and calibrating with that target gas in User Mode.

Selecting a converted target gas in **LIST** does not mean that the combustible gas sensor will respond only to that gas. The combustible gas sensor responds to a number of gases regardless of the target gas selection.

NOTE: If H₂ is selected as the target gas in **LIST**, the sensor will only respond to H₂ and will not respond to any other gas, regardless of the gas listings in Table 10.

If you select a new converted target gas, the change is saved after you turn the instrument off and on.

Table 10: Available HC Gas Conversions

Gas	Available Converted Target Gases Based on Calibrated Target Gas (Selected in Gas Select Mode)		Available Converted Target Gases During HC Gas List Condition
	CH ₄ (methane)	i-C ₄ H ₁₀ (isobutane)	
CH ₄ (methane)	-	x	O
i-C ₄ H ₁₀ (isobutane)	O	-	O
H ₂ (hydrogen)	O	O	O
CH ₃ OH (methanol)	O	O	x
C ₂ H ₂ (acetylene)	O	O	O
C ₂ H ₄ (ethylene)	O	O	O
C ₂ H ₆ (ethane)	O	x	O
C ₂ H ₅ OH (ethanol)	O	O	x

Table 10: Available HC Gas Conversions

Gas	Available Converted Target Gases Based on Calibrated Target Gas (Selected in Gas Select Mode)		Available Converted Target Gases During HC Gas List Condition
	CH4 (methane)	i-C4H10 (isobutane)	
C3H6 (propylene)	O	O	O
C3H6O (acetone)	O	O	x
C3H8 (propane)	O	x	O
C4H6 (butyne)	O	O	O
C5H10 (cyclopentane)	O	O	O
C6H6 (benzene)	O	O	x
n-C6H14 (hexane)	O	O	O
C7H8 (toluene)	O	O	x
n-C7H16 (heptane)	O	O	O
C8H10 (xylene)	O	O	x
n-C9H20 (nonane)	O	O	x
EtAc (ethyl acetate)	O	O	x
IPA (isopropyl alcohol)	O	O	x
MEK (methyl ethyl ketone)	O	O	x
MMA (methyl methacrylate)	O	O	x
DME (dimethyl ether)	O	O	x
MIBK (methyl isobutyl ketone)	O	O	x
THF (tetrahydrofuran)	O	O	x
n-C5H12 (N-Pentane)	O	O	O
x = not available O = available			

1. After entering Display Mode, press and release POWER MODE until **LIST** appears.

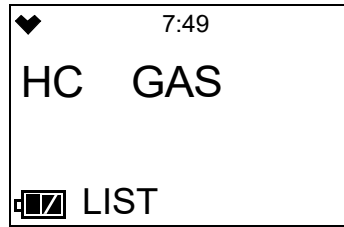

2. Press and release AIR to enter the screen. The current gas flashes at the bottom of the screen.

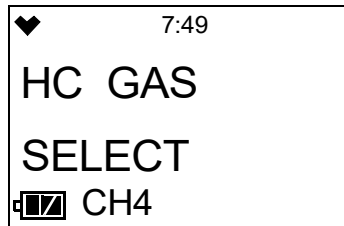

3. Use AIR to scroll through the list of gases.
4. When the desired gas is displayed, press and release POWER MODE. The changes are saved and the instrument returns to the **LIST** screen.
5. The gas formula displays at the bottom of the Measuring Mode screen. The gas selection remains selected if you turn the instrument off and on again.

Changing the User ID (USER ID)

This screen only appears if **DISP SET** in User Mode is set to **ON** (factory setting) and if **ID DISP** in Maintenance Mode is set to **ON** (factory setting is **OFF**).

Use this screen to select a user ID from the 128 user IDs that are stored in the GX-3R's memory. Before a user ID is selected on a brand new instrument, the user ID is "-----". The factory-installed user IDs have a "U_ID_XXX" format.

The user ID provides a way to identify the GX-3R user during a data logging session.

User IDs can only be selected in this menu item. In order to edit the 128 user IDs, you must use the GX-3R Datalogging Program.

1. After entering Display Mode, press and release POWER MODE until the **USER ID** screen sequence appears.

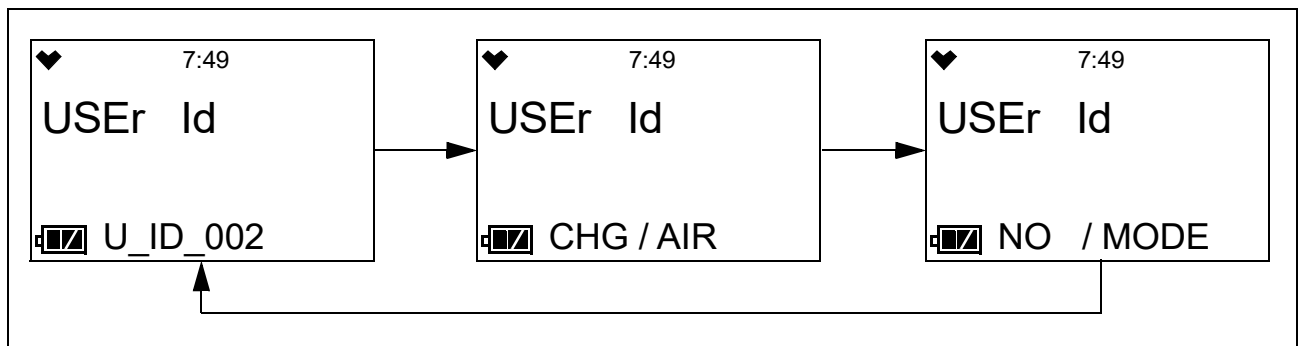

- To change the User ID, press and release AIR. The current User ID flashes.

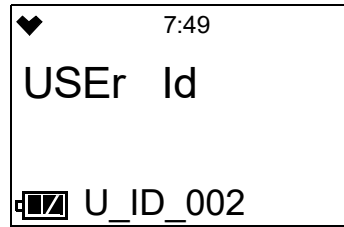

- Use AIR to scroll to the desired User ID.
- Press and release POWER MODE to save the User ID and return to the **USER ID** screen in Display Mode.

Changing the Station ID (STN ID)

This screen only appears if **DISP.SET** in User Mode is set to **ON** (factory setting) and if **ID DISP** in Maintenance Mode is set to **ON** (factory setting is **OFF**).

Use this screen to select a station ID from the 128 station IDs that are stored in the GX-3R's memory. Before a station ID is selected on a brand new instrument, the station ID is “--- -----”. The factory-installed station IDs have a “S_ID_XXX” format.

The station ID provides a way to identify the GX-3R location during a data logging session.

Station IDs can only be selected in this menu item. In order to edit the 128 station IDs, you must use the GX-3R Datalogging Program.

- After entering Display Mode, press and release POWER MODE until the **STN ID** screen sequence appears.

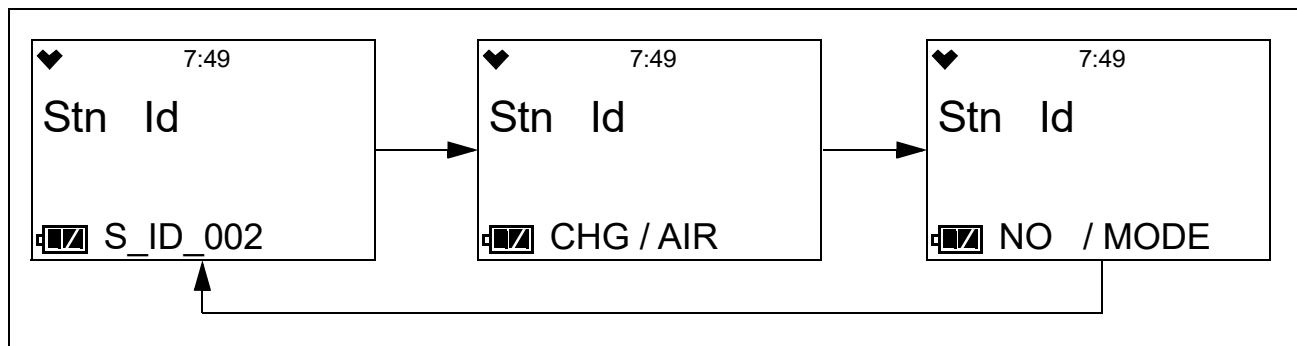

- To change the station ID, press and release AIR. The current Station ID flashes.

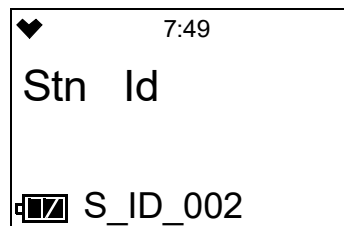

- Use AIR to scroll to the desired station ID.

4. Press and release **POWER MODE** to save the station ID and return to the **STN ID** screen in Display Mode.

Last Successful Calibration Date (CAL DATA)

The **CAL DATA** screen shows the date of each installed sensor's last successful calibration. This screen only appears if **CAL.RMDR** is set to **ON** in User Mode.

1. After entering Display Mode, press and release **POWER MODE** until **CAL DATA** appears.

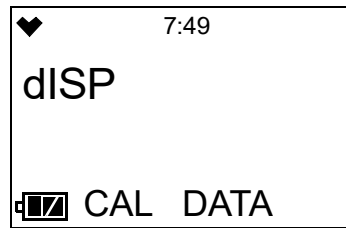

2. Press **AIR** to enter the **CAL DATA** screen and to scroll through the installed sensors.

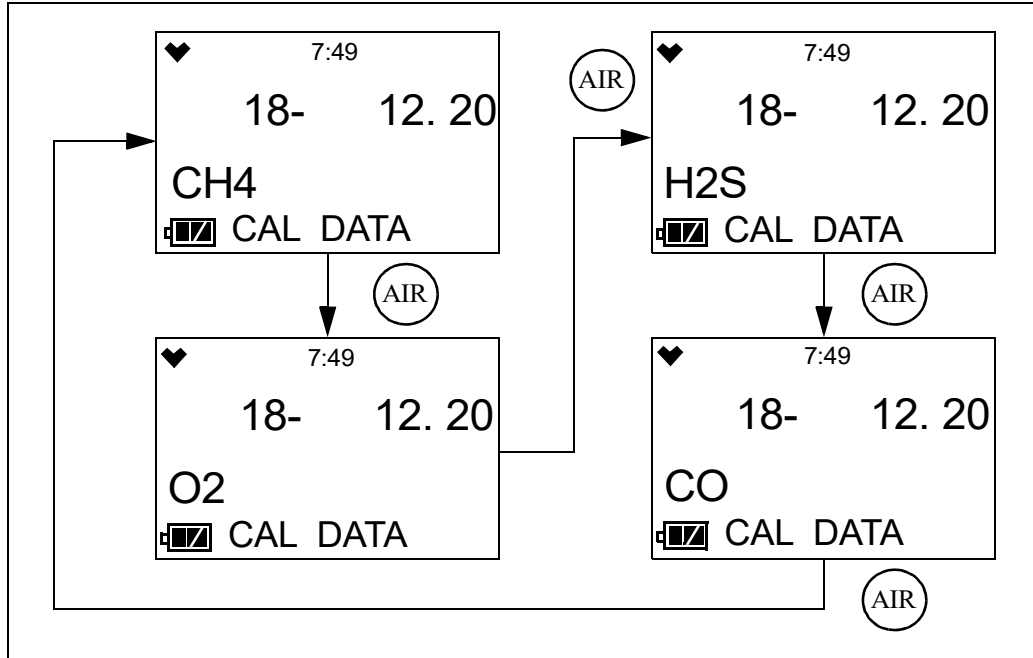

3. When you are done viewing the last calibration date for the sensors, press and release **POWER MODE** to return to the **CAL DATA** screen in Display Mode.

Last Successful Bump Test Date (BUMP DATA)

The **BUMP DATA** screen shows the date of each installed sensor's last successful bump test. This screen only appears if **BUMP.RMDR** is set to **ON**.

1. After entering Display Mode, press and release **POWER MODE** until **BUMP DATA** appears.

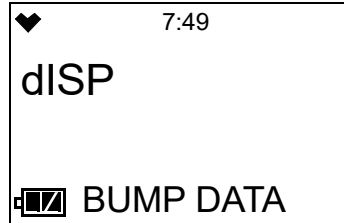

2. Press **AIR** to enter the **BUMP DATA** screen and to scroll through the installed sensors.

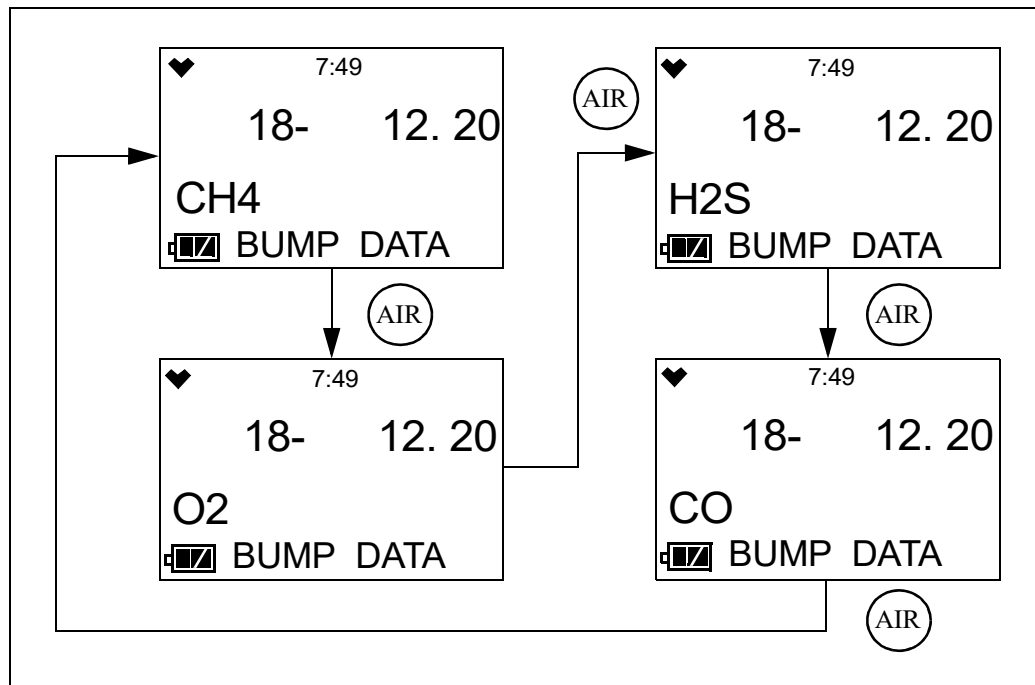

3. When you are done viewing the last bump test date for the sensors, press and release **POWER MODE** to return to the **BUMP DATA** screen in Display Mode.

Date, Time, Temperature Screen (TEMP)

The **TEMP** screen shows the instrument's date and time and the surrounding area's temperature.

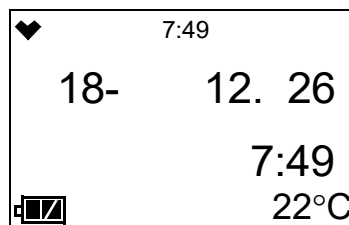

Alarm Points Screen (ALARM--PT)

The Alarm Points Screen shows the gas alarm settings for all active channels.

1. After entering Display Mode, press and release POWER MODE until **ALARM--PT** appears.

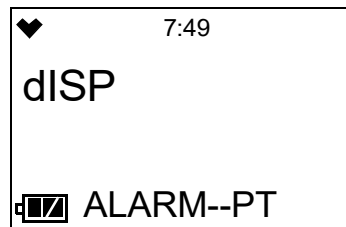

2. Press and release AIR. The Full Scale Settings screen appears and shows full scale settings for each channel.
3. Use AIR to scroll through the Warning, Alarm, Alarm H, STEL, and TWA settings.

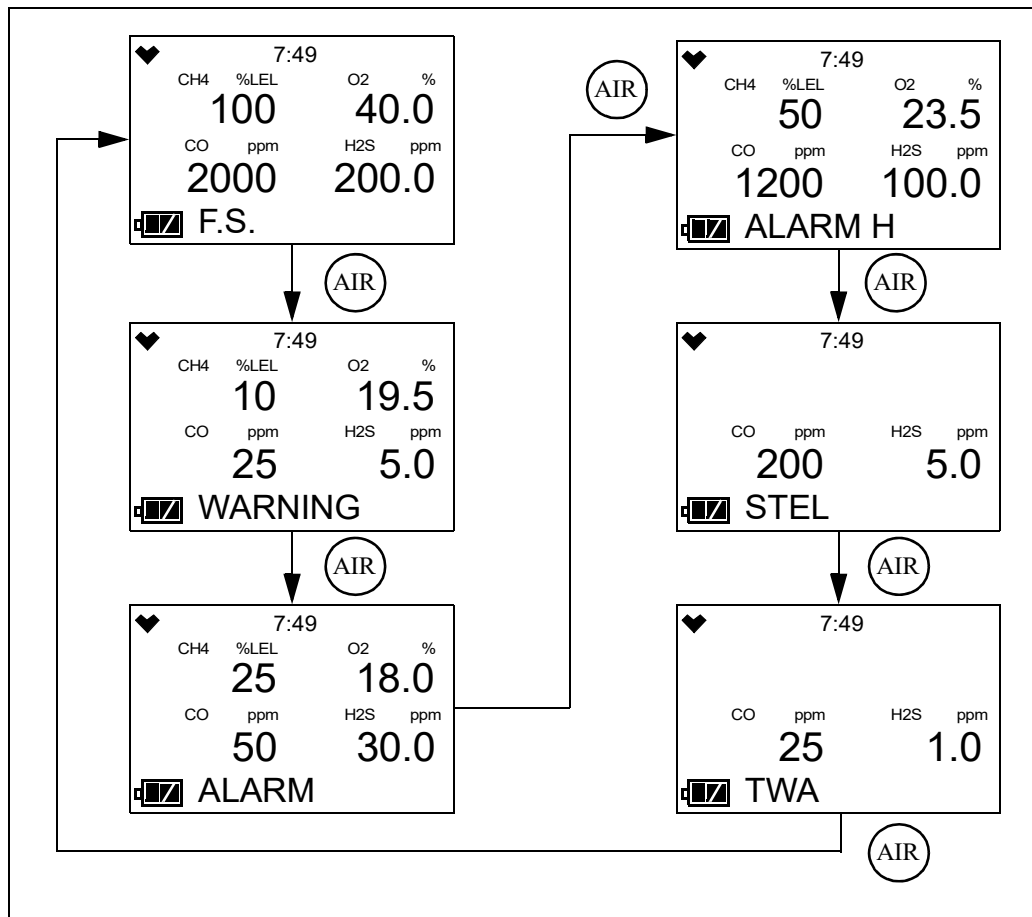

4. While viewing the alarm settings for a particular alarm point, press and release AIR and POWER MODE at the same time to simulate the alarm conditions. The buzzer will sound, the LEDs will flash, and the instrument will vibrate just as it would if the displayed condition was actually happening.
5. Press and release POWER MODE to return to the Alarm Points Screen.

Chapter 5: User Mode and Calibration

Overview

This section describes the GX-3R in User Mode. See Table 11 for a list of the items found in User Mode, the page that the menu item's instructions can be found on, and a short description of the menu item.

Table 11: User Mode Menu Items

User Mode Menu Item	Description		
BUMP (page 60)	Perform a bump test.		
	BUMP CYL X	Perform a bump test on the gases selected for Cylinder X (A-E cylinders available)	
	START	Begin the warmup sequence and enter Measuring Mode.	
	ESCAPE	Return to the BUMP menu item.	
GAS CAL (page 67)	Perform a fresh air adjustment, perform a span adjustment, change the calibration gas concentration, set the cylinder group.		
	AIR CAL (page 67)	Perform a fresh air adjustment.	
	AUTO CAL (page 68)	AUTO CAL CYL X	Perform an automatic span adjustment on the gases selected for Cylinder X (A-E cylinders available).
		START	Begin the warmup sequence and enter Measuring Mode.
		CAL-P	Set the calibration gas concentration for each gas.
		CYL SEL	Assign a cylinder (A-E) to each gas (all 4 gases set to Cylinder A is the default). For single cal operation, you would assign each gas its own cylinder.
	ESCAPE	Return to the AUTO CAL menu item.	
ESCAPE	Return to the GAS CAL menu item.		

Table 11: User Mode Menu Items

User Mode Menu Item	Description		
CAL SET (page 79)	Change calibration parameters.		
	CAL RMDR (page 79)	<p>ON (factory setting): The instrument notifies the user upon startup when a calibration is due. Notification type depends on CAL EXPD setting below.</p> <p>OFF: No notification upon startup when a calibration is due.</p>	
	CAL INT (page 80)	<p>How often the instrument needs to be calibrated.</p> <p>Options: 1 - 1000 days (factory setting is 90 days)</p>	
	CAL EXPD (page 80)	<p>Defines what action must be taken if a calibration is due upon startup.</p> <p>CONFIRM (factory setting): Press and release AIR to acknowledge that calibration is due and continue to Measuring Mode.</p> <p>CANT USE: Cannot enter Measuring Mode until a successful calibration is performed.</p> <p>NONE: A screen indicates that calibration is due but warmup sequence continues.</p>	
	ESCAPE	Return to the CAL SET menu item in User Mode.	
BUMP SET (page 81)	Change bump test parameters.		
	SETTINGS (page 82)	GAS TIME	How long gas is applied during a bump test. Choices: 30 (factory setting), 45, 60, 90 seconds
		CHECK	Percentage of calibration gas concentration that the bump test reading must be within in order to pass bump. Options: 10%, 20%, 30%, 40%, 50% (factory setting)
		CAL TIME	How long gas is applied during a calibration. GAS TIME is deducted from this time. Options: 90 (factory setting) or 120 seconds
		AUTO CAL	<p>ON (factory setting): If a bump test fails, a calibration automatically starts.</p> <p>OFF: If a bump test fails, a calibration does not automatically start.</p>
ESCAPE	Return to the SETTINGS menu item in BUMP SET .		

Table 11: User Mode Menu Items

User Mode Menu Item	Description	
BUMP SET (page 81) (cont'd)	BUMP.RMDR (page 84)	<p>ON: The instrument notifies the user upon startup when a bump test is due. Notification type depends on BUMP.EXPD setting below.</p> <p>OFF (factory setting): No notification upon startup when a bump test is due.</p>
	BUMP INT (page 84)	<p>How often the instrument needs to be bump tested.</p> <p>Options: 0 - 30 days (factory setting is 30 days)</p>
	BUMP.EXPD (page 85)	<p>Defines what action must be taken if a bump test is due upon startup.</p> <p>CONFIRM (factory setting): Press and release AIR to acknowledge that bump test is due and continue to Measuring Mode.</p> <p>CANT USE: Cannot enter Measuring Mode until a successful bump test is performed.</p> <p>NONE: A screen indicates that bump test is due but warmup sequence continues.</p>
	ESCAPE	<p>Return to the BUMP SET menu item in User Mode.</p>
ALARM-PT (page 86)	<p>Set alarm points for all channels (WARNING, ALARM, ALARM H, STEL, TWA) or reset all alarms to their default settings.</p>	
LUNCH (page 89)	<p>ON: Lunch break feature is on. Instrument asks if you want to resume TWA and PEAK readings at startup.</p> <p>OFF (factory setting): Lunch break feature is off. Instrument resets TWA and PEAK readings every time it's turned on.</p>	
BEEP (page 90)	<p>Set confirmation beep parameters.</p>	
	BEEP SEL (page 90)	<p>LED: LEDs flash and instrument vibrates based on interval defined in BEEP INT to confirm instrument is still operating.</p> <p>BUZZER: Buzzer sounds and instrument vibrates based on interval defined in BEEP INT to confirm instrument is still operating.</p> <p>LED+BUZZ: LEDs flash, buzzer sounds, and instrument vibrates based on interval defined in BEEP INT to confirm instrument is still operating.</p> <p>BUMP/CAL: LEDs flash based on interval defined in BEEP INT if bump test or calibration is due.</p> <p>ALMALRT: LEDs flash based on interval defined in BEEP INT if instrument goes into a gas alarm.</p> <p>B/C/ALM: LEDs flash based on interval defined in BEEP INT if a) bump test is due, b) calibration is due, or c) instrument goes into a gas alarm.</p> <p>OFF (factory setting): No alerts to confirm instrument is still operating or that a bump test or calibration is due.</p>

Table 11: User Mode Menu Items

User Mode Menu Item	Description	
BEEP (page 90) (cont'd)	BEEP INT (page 91)	Confirmation alert interval. Confirmation type defined in BEEP SEL. Options: 0.5 minute and 1 to 99 minutes in 1 minute increments. The factory setting is 5 minutes.
	ESCAPE	Return to the BEEP menu item in User Mode.
BL TIME (page 92)	How long the back light stays on after the last button press. Options: 0 - 255 seconds or OFF . The factory setting is 30 seconds.	
KEY TONE (page 92)	ON (factory setting): Buzzer sounds when button is pressed. OFF : Buzzer does not sound when button is pressed.	
DISP SET (page 93)	OFF : LIST , USER ID , and STN ID screens do not appear in Display Mode. ON (factory setting): LIST item appears in Display Mode. USER ID and STN ID screens appear if ID DISP in Maintenance Mode is also set to ON .	
ZERO SUP (page 93)	ON (factory setting): Not intended for field adjustment. The suppression values are: Combustible Gas: 2% LEL O ₂ : 0.5% volume H ₂ S: 0.3 ppm CO: 2 ppm <i>NOTE: Only appears if ZSUP.DISP is set to ON in Maintenance Mode.</i>	
ZERO.FLWR (page 94)	ON (factory setting): Not intended for field adjustment. Oxygen channel does not support zero follower functionality. <i>NOTE: Only appears if ZFLW.DISP is set to ON in Maintenance Mode.</i>	
DATE (page 94)	Set the instrument's date and time.	
PASSWORD (page 95)	ON : User Mode is password-protected. Factory-set password is 0405 . OFF (factory setting): User Mode is not password-protected.	
ROM/SUM (page 96)	View the firmware information for the GX-3R's sensor board and main board.	
START (page 96)	Press and release POWER MODE to begin the warmup sequence and enter Measuring Mode.	

Entering User Mode

WARNING: *The GX-3R is not in operation as a gas detector while in User Mode.*

1. Take the GX-3R to a non-hazardous location and turn it off if it is on.
2. Press and hold AIR, then press and hold POWER MODE. When you hear a beep, release the buttons.
3. The screen that appears will depend on the setting of User Mode's **PASSWORD** item.
If **PASSWORD** is set to **OFF** (factory setting), continue with Step 6.
If **PASSWORD** is set to **ON**, continue with Step 4.

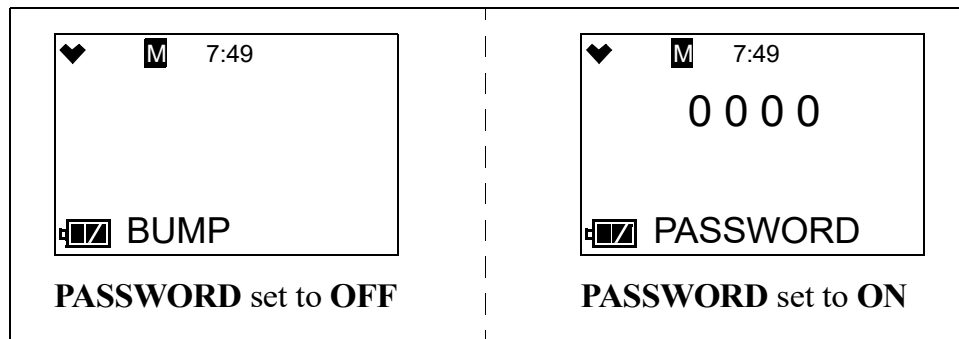

4. If **PASSWORD** has been set to **ON** in User Mode, a password screen appears. The first digit is flashing.
5. Use AIR to select each password number then press POWER MODE to save it and move on to the next number. To go back a number, press and hold AIR and POWER MODE for a few seconds. To reverse the direction of change (ie. from increasing to decreasing or vice versa):
 - a. Press and hold AIR.
 - b. Immediately press POWER MODE and then release both buttons.
6. The **BUMP** menu item appears.

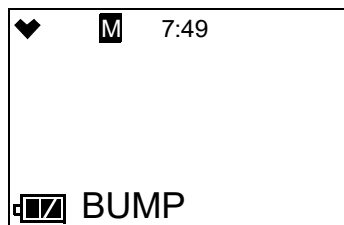

7. **M** at the top of the screen indicates that the GX-3R is in User Mode.
8. Use AIR to move through the User Mode menu items.

Tips for Using User Mode

- To scroll from one menu item to the next, press and release AIR. To reverse the scrolling direction:
 - a. Press and hold AIR.
 - b. Immediately press POWER/MODE and then release both buttons.
 - c. The scrolling direction returns to the original direction when you exit and reenter a menu.
- To skip an item when a question is asked, press and release AIR.
- To enter an item and to save any changes, press and release POWER MODE.
- To change a flashing parameter, press and release AIR. To reverse the direction of change (ie. from increasing to decreasing or vice versa):
 - a. Press and hold AIR.
 - b. Immediately press POWER MODE and then release both buttons.
- To exit an entered menu item without saving a change, press and hold AIR and POWER MODE for a few seconds.

Performing a Bump Test (BUMP)

Bump test the instrument before each day's use with a known concentration of each target gas. The instrument does not need to be calibrated unless it does not pass the bump test.

To bump test the GX-3R, you will need:

- Known calibrating samples of the gases being detected.

Table 12: Calibration Concentration Limits

Channel	Min. Cal. Gas Concentration	Max. Cal. Gas Concentration
Combustible Gas	5% LEL	75% LEL
Oxygen	0.0%	17.0%
Hydrogen Sulfide	1.0 ppm	200.0 ppm
Carbon Monoxide	15 ppm	2,000 ppm

- 0.25 LPM fixed flow regulator
 - Non-absorbent tubing
 - Calibration cup
1. Confirm that the GX-3R's calibration gas values match the concentrations listed on the calibration gas cylinder(s) as described on page 74.
 2. Confirm that your cylinder selections are appropriate as described on page 77.

- Install the calibration cup onto the GX-3R. Use the label and imprinting to make sure that the calibration cup gets installed in the correct orientation relative to the GX-3R. Be sure the calibration cup is pushed on all the way.

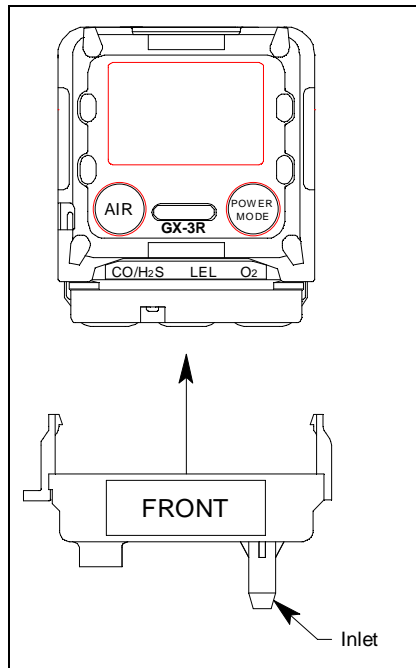
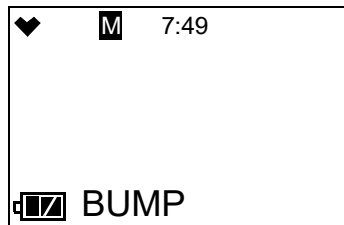
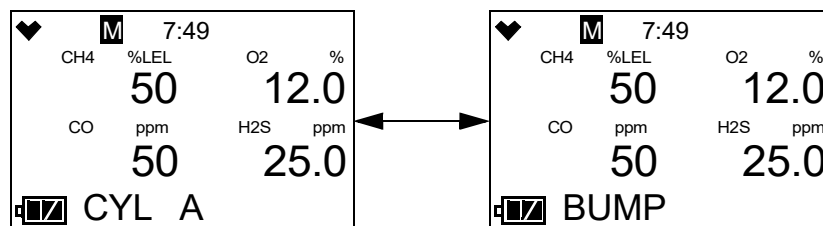

Figure 7: Calibration Cup Installation

- Use the tubing to connect the regulator to the inlet of the calibration cup.
- While in User Mode, press AIR to scroll to **BUMP**.



- Press and release POWER MODE. The display shows the gases assigned to Cylinder A and their assigned calibration values (see page 74 if the calibration values do not match the calibration gas cylinder’s concentrations). The bottom of the screen alternates between “CYL A” and “BUMP”.



- If necessary, use AIR to scroll to the Bump screen for the gas(es) you want to bump test. As shipped from the factory, combustible gas, O₂, H₂S, and CO are assigned to Cylinder A. If a H₂-compensated CO sensor is installed, H₂ is assigned to Cylinder D but there is no reason to bump test the H₂ response.
- Make sure the GX-3R has been turned on for at least 45 seconds before continuing.

9. For toxic gas cylinders (like cylinders containing H₂S), it is important to vent the regulator while installing it onto the cylinder. Venting the regulator during installation helps prevent air from getting into the cylinder and degrading the gas. Open the regulator by turning the knob counterclockwise and install it onto the cylinder.
10. Press and release POWER MODE.
11. The gas readings flash, the bottom of the screen alternates between “APPLY” and “BUMP”, and the top of the screen counts down from the time set in **BUMP SET\SETTINGS\GAS TIME**.

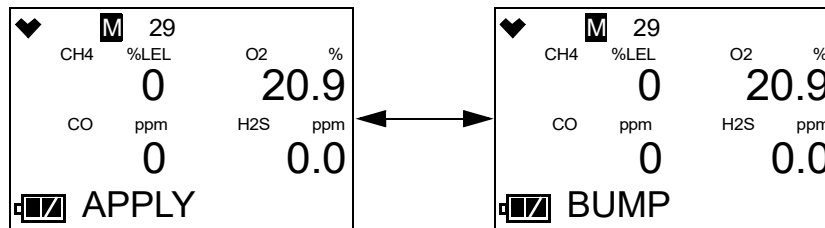

NOTE: To back out of the gas application screen without performing the bump test, press and release AIR and POWER MODE together.

12. At the end of the countdown, the instrument analyzes the results. Follow the flow chart to determine the bump test outcome.

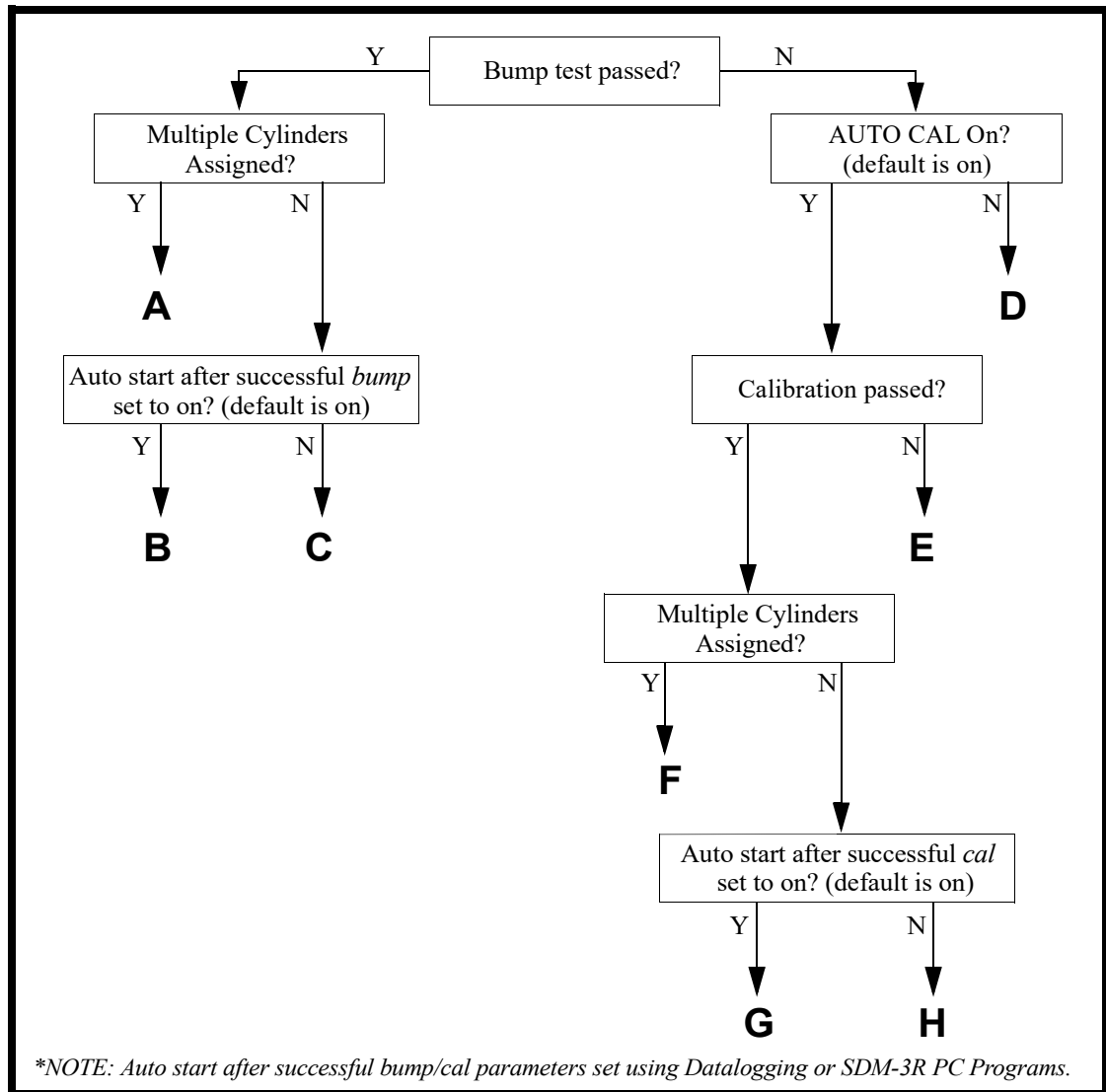
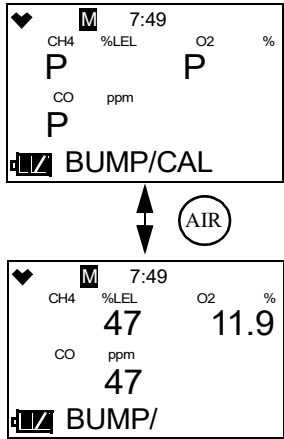
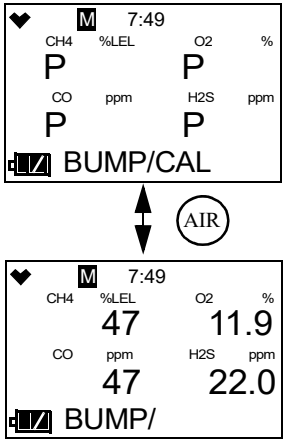
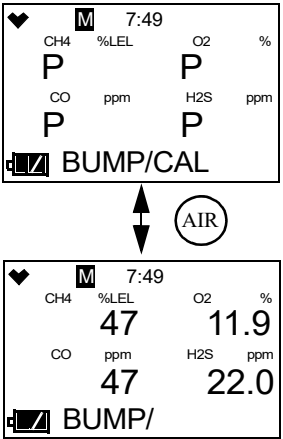
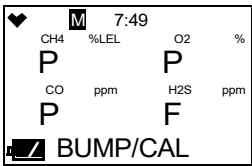
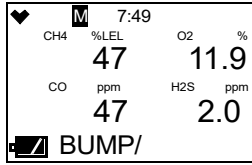
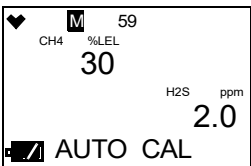
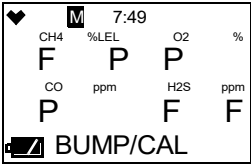
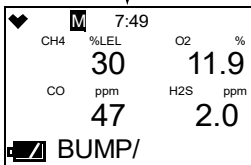
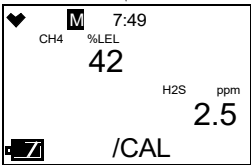
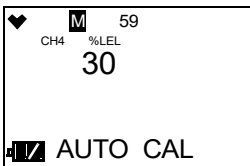
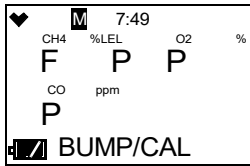
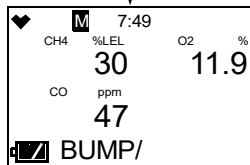
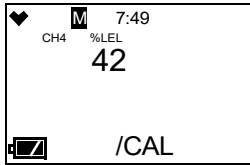
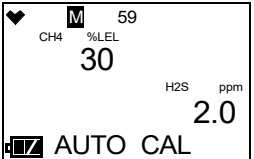
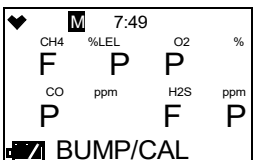
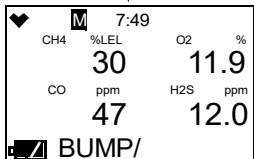
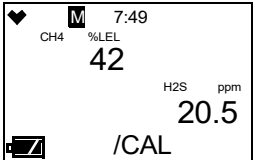
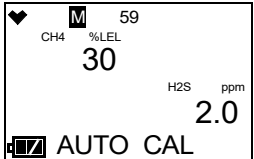
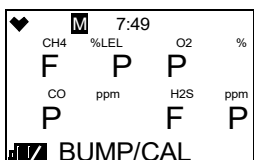
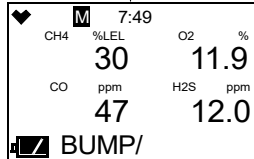
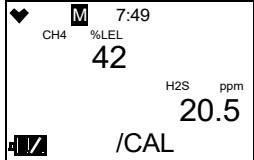

Figure 8: Bump Test Flow Chart

Option A from Flow Chart	Option B from Flow Chart	Option C from Flow Chart
<ul style="list-style-type: none"> • Bump test passed • Multiple cylinders assigned 	<ul style="list-style-type: none"> • Bump test passed • One cylinder assigned • Auto Start After Successful Bump set to ON (factory setting) 	<ul style="list-style-type: none"> • Bump test passed • One cylinder assigned • Auto Start After Successful Bump set to OFF (factory setting is ON)
<p>1. The instrument indicates that all channels passed the bump test. Use AIR to scroll between the bump test results and the bump test gas readings.</p> <div style="text-align: center;">  <p>The diagram shows two screenshots of the instrument's display. The top screenshot shows the 'BUMP/CAL' menu with 'P' indicators for CH4, %LEL, O2, and CO. The bottom screenshot shows the gas readings: CH4 %LEL O2 % with values 47, 11.9, and CO ppm with value 47. A double-headed vertical arrow with an 'AIR' button icon indicates the scroll action between the two screens.</p> </div> <ol style="list-style-type: none"> 2. Close the regulator. 3. Press and release POWER MODE to move to the BUMP CYL X screen for the next cylinder. 4. Unscrew the regulator from the first cylinder and screw it into the next cylinder. 5. Repeat Step 9 through Step 12. 6. After the last cylinder is bump tested, press and release POWER MODE to go to the START item in the BUMP menu. 7. Remove the calibration cup. 8. Press and release POWER MODE to enter Measuring Mode. 	<p>1. The instrument indicates that all channels passed the bump test. Use AIR to scroll between the bump test results and the bump test gas readings.</p> <div style="text-align: center;">  <p>The diagram shows two screenshots of the instrument's display. The top screenshot shows the 'BUMP/CAL' menu with 'P' indicators for CH4, %LEL, O2, CO, and H2S. The bottom screenshot shows the gas readings: CH4 %LEL O2 % with values 47, 11.9, and CO ppm with value 47, and H2S ppm with value 22.0. A double-headed vertical arrow with an 'AIR' button icon indicates the scroll action between the two screens.</p> </div> <ol style="list-style-type: none"> 2. Close the regulator. 3. Unscrew the regulator. 4. Remove the calibration cup. 5. Press and release POWER MODE to enter Measuring Mode. 	<p>1. The instrument indicates that all channels passed the bump test. Use AIR to scroll between the bump test results and the bump test gas readings.</p> <div style="text-align: center;">  <p>The diagram shows two screenshots of the instrument's display. The top screenshot shows the 'BUMP/CAL' menu with 'P' indicators for CH4, %LEL, O2, CO, and H2S. The bottom screenshot shows the gas readings: CH4 %LEL O2 % with values 47, 11.9, and CO ppm with value 47, and H2S ppm with value 22.0. A double-headed vertical arrow with an 'AIR' button icon indicates the scroll action between the two screens.</p> </div> <ol style="list-style-type: none"> 2. Close the regulator. 3. Unscrew the regulator. 4. Remove the calibration cup. 5. Press and release POWER MODE to return to the START item in the BUMP menu. 6. Press and release POWER MODE to enter Measuring Mode.

Option D from Flow Chart	Option E from Flow Chart	Option F from Flow Chart
<ul style="list-style-type: none"> • Bump test failed • A-CAL set to OFF (factory setting is ON) 	<ul style="list-style-type: none"> • Bump test failed • A-CAL set to ON (factory setting) • Calibration failed 	<ul style="list-style-type: none"> • Bump test failed • A-CAL set to ON (factory setting) • Calibration passed • Multiple cylinders assigned
<p>1. The instrument shows which channels passed or failed the bump test. The LEDs flash and the buzzer sounds. Use AIR to scroll between the results and the readings.</p>  <p style="text-align: center;">↑ ↓ (AIR)</p>  <p>2. Close the regulator. 3. Unscrew the regulator. 4. Remove the calibration cup. 5. Press and release POWER MODE to return to the BUMP CYL A item in the BUMP menu. 6. Use AIR to scroll to START and press and release POWER MODE to enter Measuring Mode. 7. Calibrate the GX-3R as soon as possible.</p>	<p>1. A calibration immediately and automatically starts. Continue to apply the calibration gas.</p> <p>2. The calibration time is the difference between the GAS TIME and the CAL TIME values defined in the BUMP SET\SETTINGS item in User Mode.</p>  <p>3. The instrument shows which channels passed or failed the bump test/calibration. The LEDs flash and the buzzer sounds. Use AIR to scroll between the results and the readings.</p>  <p style="text-align: center;">↑ ↓ (AIR)</p>  <p style="text-align: center;">↑ ↓ (AIR)</p>  <p>4. Close the regulator. 5. Unscrew the regulator. 6. Remove the calibration cup. 7. Press and release POWER MODE to return to the BUMP CYL A item in the BUMP menu. 8. Use AIR to scroll to START and press and release POWER MODE to enter Measuring Mode.</p>	<p>1. A calibration immediately and automatically starts. Continue to apply the calibration gas.</p> <p>2. The calibration time is the difference between the GAS TIME and the CAL TIME values defined in the BUMP SET\SETTINGS item in User Mode.</p>  <p>3. The instrument shows which channels passed or failed the bump test/calibration. Use AIR to scroll between the results and the readings.</p>  <p style="text-align: center;">↑ ↓ (AIR)</p>  <p style="text-align: center;">↑ ↓ (AIR)</p>  <p>4. Close the regulator. 5. Press and release POWER MODE to move to the BUMP CYL X screen for the next cylinder. 6. Unscrew the regulator from the first cylinder and screw it into the next cylinder. 7. Repeat Step 9 through Step 12. 8. After the last cylinder is bump tested, press and release POWER MODE to go to the START item in the BUMP menu. 9. Remove the calibration cup. 10. Press and release POWER MODE to enter Measuring Mode.</p>

Option G from Flow Chart	Option H from Flow Chart
<ul style="list-style-type: none"> • Bump test failed • A-CAL set to ON (factory setting) • Calibration passed • One cylinder assigned • Auto Start After Successful Cal set to ON (factory setting) 	<ul style="list-style-type: none"> • Bump test failed • A-CAL set to ON (factory setting) • Calibration passed • One cylinder assigned • Auto Start After Successful Cal set to OFF (factory setting is ON)
<ol style="list-style-type: none"> 1. A calibration immediately and automatically starts. Continue to apply the calibration gas. 2. The calibration time is the difference between the GAS TIME and the CAL TIME values defined in the BUMP SET\SETTINGS item in User Mode.  <ol style="list-style-type: none"> 3. The instrument shows which channels passed or failed the bump test/calibration. Use AIR to scroll between the results and the readings.  <p style="text-align: center;">↑ (AIR)</p>  <p style="text-align: center;">↑ (AIR)</p>  <ol style="list-style-type: none"> 4. Close the regulator. 5. Unscrew the regulator. 6. Remove the calibration cup. 7. Press and release POWER MODE to enter Measuring Mode. 	<ol style="list-style-type: none"> 1. A calibration immediately and automatically starts. Continue to apply the calibration gas. 2. The calibration time is the difference between the GAS TIME and the CAL TIME values defined in the BUMP SET\SETTINGS item in User Mode.  <ol style="list-style-type: none"> 3. The instrument shows which channels passed or failed the bump test/calibration. Use AIR to scroll between the results and the readings.  <p style="text-align: center;">↑ (AIR)</p>  <p style="text-align: center;">↑ (AIR)</p>  <ol style="list-style-type: none"> 4. Close the regulator. 5. Unscrew the regulator. 6. Remove the calibration cup. 7. Press and release POWER MODE to return to the START item in the BUMP menu. 8. Press and release POWER MODE to enter Measuring Mode.

Performing a Calibration (GAS CAL)

Calibration Notes

- To fully calibrate the sensors, you must do a fresh air adjustment (**AIR CAL**) and a span adjustment (**AUTO CAL**).
- Bump test the instrument before each day's use with a known concentration of each target gas. A bump test can be done in User Mode's **BUMP** item or by applying gas in Measuring Mode. The instrument does not need to be calibrated unless it does not pass the User Mode bump test or does not respond appropriately, as defined by the user, in Measuring Mode.
- The hydrogen response for the H₂-compensated CO sensor needs to be set both monthly and when the sensor is replaced.

AIR CAL

1. Find a fresh air environment, an environment of normal oxygen content (20.9%) that is free of toxic and combustible gases.
2. While in User Mode, press AIR to scroll to **GAS CAL**.

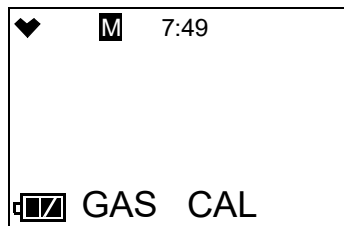

3. Press and release POWER MODE. The **AIR CAL** menu item appears.

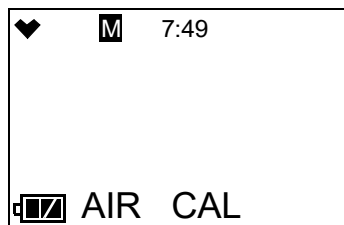

4. Press and release POWER MODE to enter the **AIR CAL** menu.

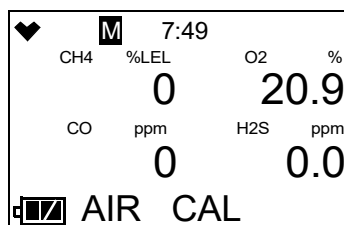

5. Make sure the GX-3R has been turned on for at least 45 seconds before continuing.

- Press and hold AIR until the screen prompts you to release it.

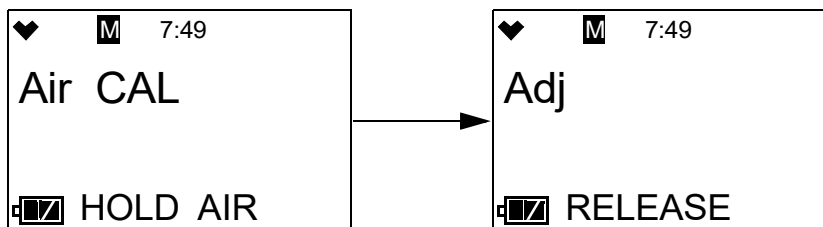

- If the fresh air adjustment passes, the instrument returns to the **GAS CAL** menu.
- If the fresh air adjustment fails, “FAIL AIR” displays. Press and release POWER MODE to acknowledge the failure. See “This product is an explosion-proof product and is not to be disassembled or modified with the exception of specified parts.” on page 97.

Performing a Span Adjustment in AUTO CAL

Preparing for a Span Adjustment

To adjust the span on the GX-3R, you will need the following:

- Known concentrations of the gases being detected

Table 13: Calibration Concentration Limits

Channel	Min. Cal. Concentration	Max. Cal. Concentration
Combustible Gas	5% LEL	75% LEL
Oxygen	0.0%	17.0%
Hydrogen Sulfide	1.0 ppm	200.0 ppm
Carbon Monoxide	15 ppm	2,000 ppm
Hydrogen (for H ₂ -compensated CO sensor); sensor needs monthly calibration	25 ppm	2,000 ppm

- 0.25 LPM fixed flow regulator
 - Non-absorbent tubing
 - Calibration cup
- Confirm that the GX-3R’s calibration gas values match the concentrations listed on the calibration gas cylinder(s) as described on page 74.
 - Confirm that your cylinder selections are appropriate as described on page 77.

3. Install the calibration cup onto the GX-3R. Use the label and imprinting to make sure that the calibration cup gets installed in the correct orientation relative to the GX-3R. Be sure the calibration cup is pushed on all the way.

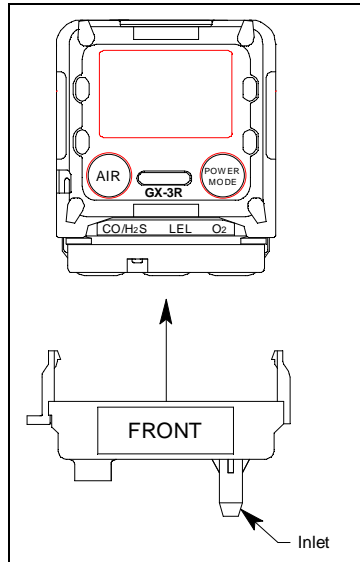
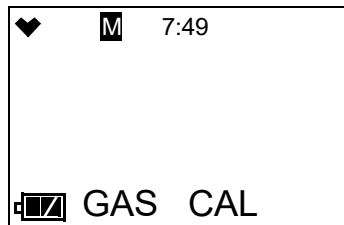

Figure 9: Calibration Cup Installation

4. Use the tubing to connect the regulator to the inlet of the calibration cup.

Performing a Span Adjustment

1. While in User Mode, press AIR to scroll to **GAS CAL**.



2. Press and release POWER MODE. The **AIR CAL** menu item appears.
3. Use AIR to scroll to the **AUTO CAL** menu item.

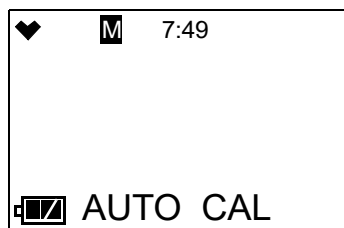

- Press and release POWER MODE. The display shows the gases assigned to Cylinder A and their assigned calibration values (see page 74 if the calibration values do not match the calibration gas cylinder's concentrations). The bottom of the screen alternates between "CYL A" and "AUTO CAL".

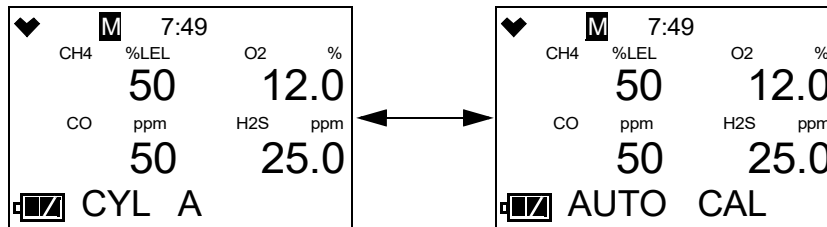

- If necessary, use AIR to scroll to the Auto Cal screen for the gas(es) you want to calibrate. As shipped from the factory, combustible gas, O₂, H₂S, and CO are assigned to Cylinder A. If a H₂-compensated CO sensor is installed, H₂ is assigned to Cylinder D.
- Make sure the GX-3R has been turned on for at least 45 seconds before continuing.
- Press and release POWER MODE.
- The gas readings flash and the bottom of the screen alternates between "APPLY" and "AUTO CAL".

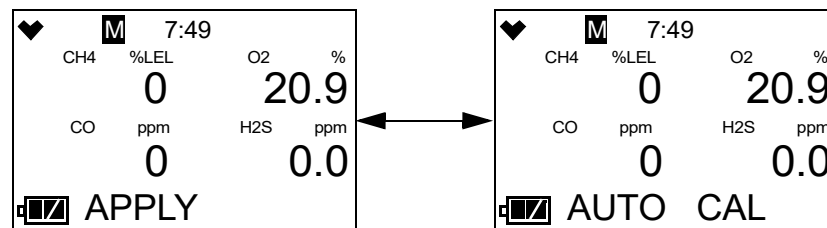

NOTE: To back out of the gas application screen without performing the bump test, press and release AIR and POWER MODE together.

- For toxic gas cylinders (like cylinders containing H₂S), it is important to vent the regulator while installing it onto the cylinder. Venting the regulator during installation helps prevent air from getting into the cylinder and degrading the gas. Open the regulator by turning the knob counterclockwise and install it onto the cylinder.
- Allow the gas to flow for 1 minute.
- Press and release POWER MODE.

12. Follow the flow chart to determine the calibration outcome.

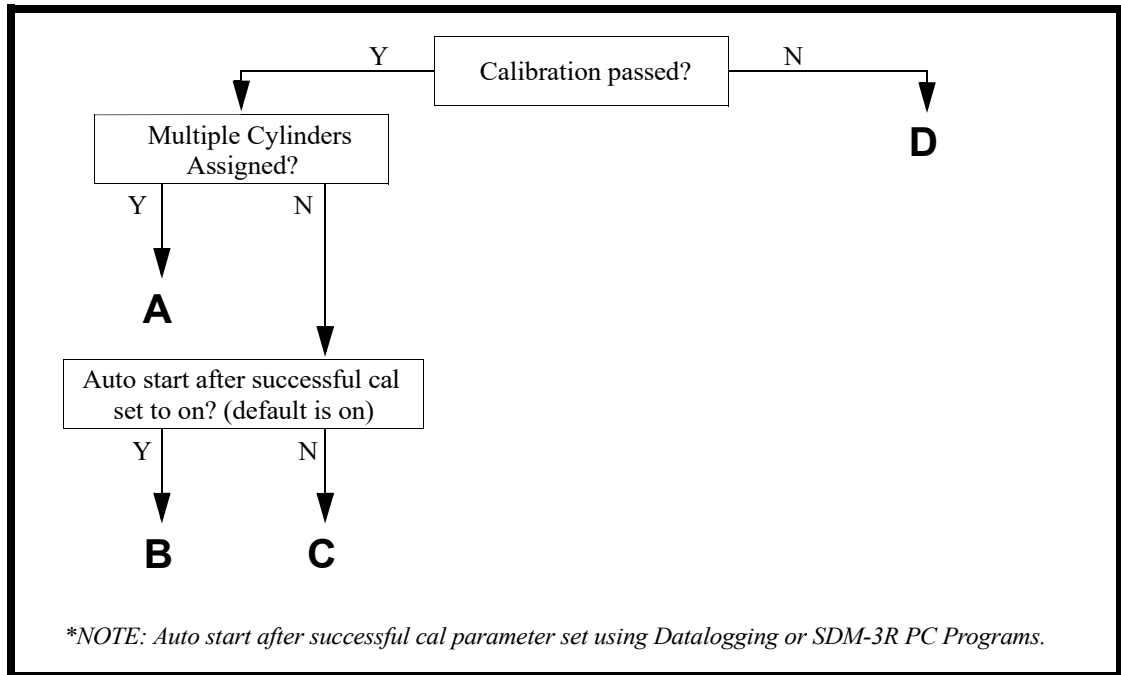
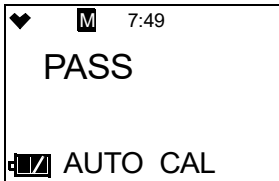
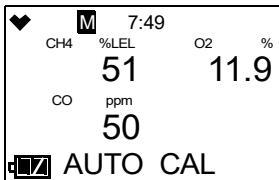
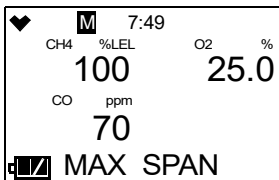
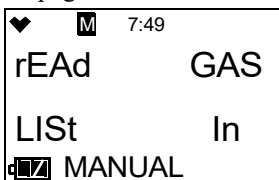
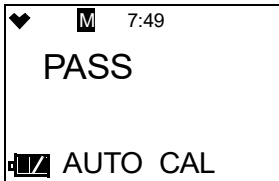
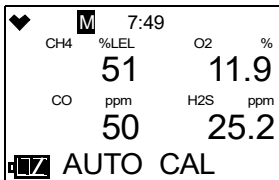
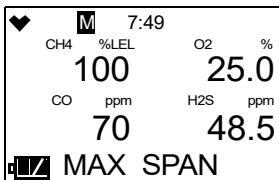
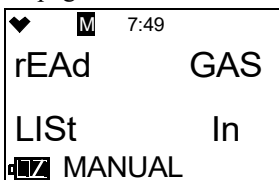
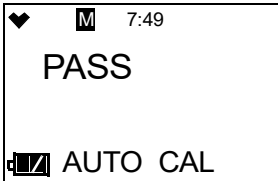
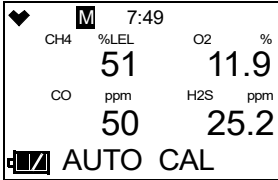
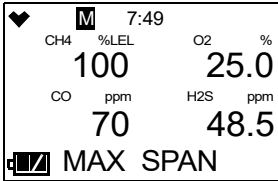
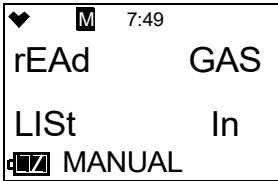
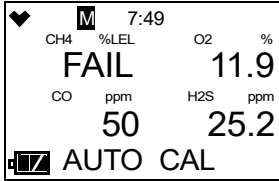

Figure 10: Calibration Flow Chart

Option A from Flow Chart	Option B from Flow Chart
<ul style="list-style-type: none"> • Calibration passed • Multiple cylinders assigned 	<ul style="list-style-type: none"> • Calibration passed • One cylinder assigned • Auto Start After Successful Cal set to ON (factory setting)
<ol style="list-style-type: none"> The instrument indicates that all channels passed the calibration.  The instrument shows the current gas readings.  If MAX SPAN is set to ON (default is OFF, see page 138), the response reading's max adjustment is displayed. A max span of 100% LEL on the combustible channel indicates that the reading could have been adjusted up to 100% LEL. If the max span value is close to the calibration gas value, the sensor should be replaced soon. The max adjustment is either twice the calibration value or full scale, whichever is lower. The max adjustment indicated for the oxygen channel is 25.0% volume.  If the combustible gas sensor is nearing expiration, Display Mode's LIST item becomes limited. Press POWER MODE to acknowledge. See page 42 for a description of the HC Gas List condition and page 48 for the limited conversion list.  <ol style="list-style-type: none"> Close the regulator. The instrument continues to the AUTO CAL CYL X screen. Unscrew the regulator from the first cylinder and screw it into the next cylinder. Press and release POWER MODE to start the next cylinder's calibration. Repeat Step 9 through Step 12. After the last cylinder is calibrated, the instrument continues to the START item in the AUTO CAL menu. Remove the calibration cup. Press and release POWER MODE to enter Measuring Mode. 	<ol style="list-style-type: none"> The instrument indicates that all channels passed the calibration.  The instrument shows the current gas readings.  If MAX SPAN is set to ON (default is OFF, see page 138), the response reading's max adjustment is displayed. A max span of 100% LEL on the combustible channel indicates that the reading could have been adjusted up to 100% LEL. If the max span value is close to the calibration gas value, the sensor should be replaced soon. The max adjustment is either twice the calibration value or full scale, whichever is lower. The max adjustment indicated for the oxygen channel is 25.0% volume.  If the combustible gas sensor is nearing expiration, Display Mode's LIST item becomes limited. Press POWER MODE to acknowledge. See page 42 for a description of the HC Gas List condition and page 48 for the limited conversion list.  <ol style="list-style-type: none"> Close the regulator. Unscrew the regulator. Remove the calibration cup. The instrument automatically begins its warmup sequence and enters Measuring Mode.

Option C from Flow Chart	Option D from Flow Chart
<ul style="list-style-type: none"> • Calibration passed • One cylinder assigned • Auto Start After Successful Cal set to OFF (factory setting is ON) 	<ul style="list-style-type: none"> • Calibration failed
<p>1. The instrument indicates that all channels passed the calibration.</p>  <p>2. The instrument shows the current gas readings.</p>  <p>3. If MAX SPAN is set to ON (default is OFF, see page 138), the response reading's max adjustment is displayed. A max span of 100% LEL on the combustible channel indicates that the reading could have been adjusted up to 100% LEL. If the max span value is close to the calibration gas value, the sensor should be replaced soon. The max adjustment is either twice the calibration value or full scale, whichever is lower. The max adjustment indicated for the oxygen channel is 25.0% volume.</p>  <p>4. If the combustible gas sensor is nearing expiration, Display Mode's LIST item becomes limited. Press POWER MODE to acknowledge. See page 42 for a description of the HC Gas List condition and page 48 for the limited conversion list.</p>  <p>5. Close the regulator.</p> <p>6. Unscrew the regulator.</p> <p>7. Remove the calibration cup.</p> <p>8. The instrument continues to the START item in the AUTO CAL menu.</p> <p>9. Press and release POWER MODE to enter Measuring Mode.</p>	<p>1. The instrument indicates which channels failed the calibration.</p>  <p>2. Close the regulator.</p> <p>3. Unscrew the regulator.</p> <p>4. Remove the calibration cup.</p> <p>5. Press and release POWER MODE to return to the AUTO CAL CYL X screen in the AUTO CAL menu.</p> <p>6. See “This product is an explosion-proof product and is not to be disassembled or modified with the exception of specified parts.” on page 97.</p>

Setting the Calibration Values in CAL--P

1. While in User Mode, press AIR to scroll to **GAS CAL**.

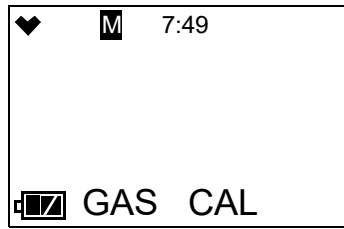

2. Press and release POWER MODE. The **AIR CAL** menu item appears.
3. Use AIR to scroll to the **AUTO CAL** menu item.

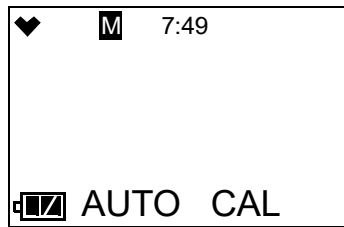

4. Press and release POWER MODE. The Auto Cal screen for gases assigned to Cylinder A appears.
5. Use AIR to scroll to **CAL--P**.

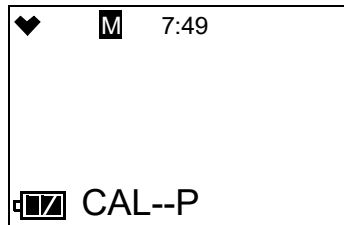

6. Press and release POWER MODE. The combustible gas channel appears.

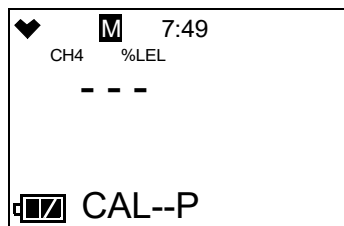

- Use AIR to scroll to the channel whose calibration gas value you want to change.

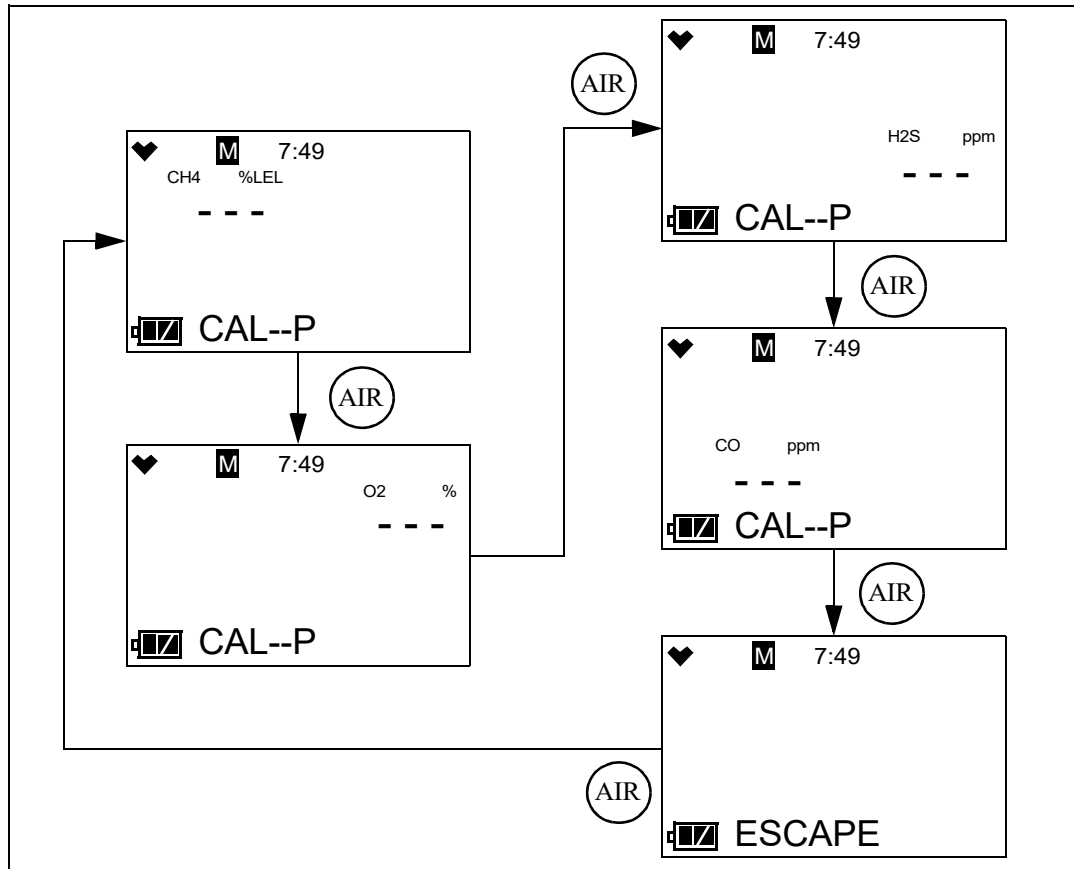

- Press and release POWER MODE. The calibration value begins to flash. In the example below, the combustible gas channel is selected.

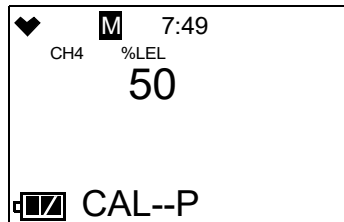

9. Use AIR to adjust the calibration gas value. The calibration gas value in the instrument must match the value listed on the calibration gas cylinder you are using for that channel. Limits on the calibration gas value are shown in Table 14.

Table 14: Calibration Concentration Limits

Channel	Min. Cal. Concentration	Max. Cal. Concentration
Combustible Gas	5% LEL	75% LEL
Oxygen	0.0%	17.0%
Hydrogen Sulfide	1.0 ppm	200.0 ppm
Carbon Monoxide	15 ppm	2,000 ppm
Hydrogen (for H ₂ -compensated CO sensor); sensor needs monthly calibration	25 ppm	2,000 ppm

10. Press and release POWER MODE to save the change. The calibration gas value stops flashing and the unit returns to the channel selection screen.
11. Repeat Step 7 through Step 10 for any other channels that need to be changed.
12. Use AIR to scroll to **ESCAPE**.
13. Press and release POWER MODE. The instrument returns to the **CAL--P** menu item in the Auto Cal Menu.
14. Press AIR to scroll to **ESCAPE**.
15. Press and release POWER MODE. The instrument returns to the **AUTO CAL** menu item in the **GAS CAL** Menu.
16. See “Exiting the GAS CAL Menu” on page 79 to return to User Mode.

Making Cylinder Selections in CYL SEL

The **CYL SEL** menu item allows you to group channels together for calibration. As shipped from the factory, the standard 4 channels (combustible gas, O₂, H₂S, and CO) are assigned to Cylinder A. As shipped from the factory, the H₂ response for the H₂-compensated CO sensor is assigned to Cylinder D. There are 5 cylinder assignments available: A, B, C, D, and E. To calibrate each channel separately, assign each channel to a different cylinder (ie. Cylinder A: combustible gas, Cylinder B: O₂, Cylinder C: H₂S, Cylinder D: CO).

1. While in User Mode, press AIR to scroll to **GAS CAL**.

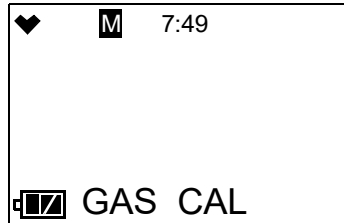

2. Press and release POWER MODE. The **AIR CAL** menu item appears.
3. Use AIR to scroll to the **AUTO CAL** menu item.

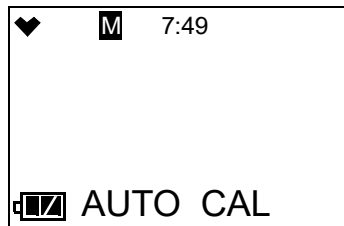

4. Press and release POWER MODE. The Auto Cal screen for gases assigned to Cylinder A displays.
5. Use AIR to scroll to **CYL SEL**.

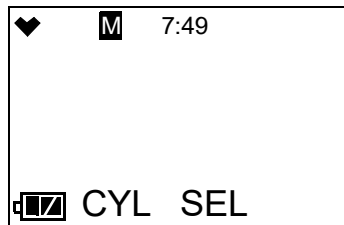

6. Press and release POWER MODE. The combustible gas channel displays.

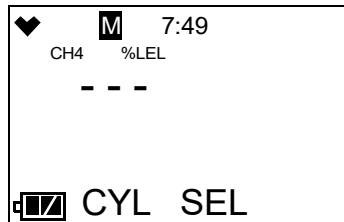

7. Use AIR to scroll to the channel whose cylinder assignment you want to change.

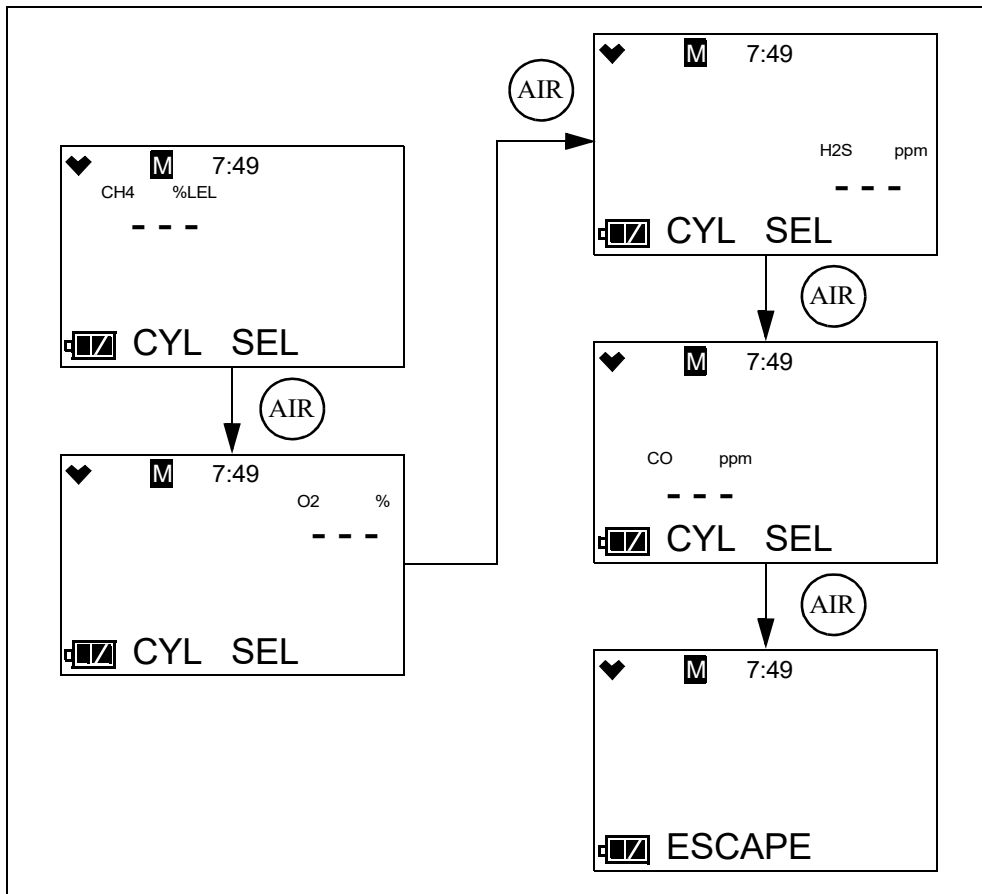

8. Press and release POWER MODE. The current setting flashes. In the example below, the combustible gas channel is selected.

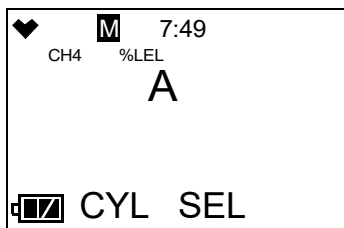

9. Use AIR to change the cylinder assignment. The choices are A, B, C, D, and E.
10. Press and release POWER MODE to save the change. The cylinder assignment stops flashing and the unit returns to the channel selection screen.
11. Repeat Step 7 through Step 10 for any other channels that need to be changed.
12. Use AIR to scroll to **ESCAPE**.
13. Press and release POWER MODE. The instrument returns to the **CYL SEL** menu item in the Auto Cal Menu.
14. Press AIR to scroll to **ESCAPE**.

15. Press and release POWER MODE. The instrument returns to the **AUTO CAL** menu item in the **GAS CAL** menu.
16. See “Exiting the GAS CAL Menu” on page 79 to return to User Mode.

Exiting the GAS CAL Menu

1. While in the **GAS CAL** menu, press AIR to scroll to **ESCAPE**.
2. Press and release POWER MODE. The instrument returns to the **GAS CAL** menu item in User Mode.
3. See “Entering Measuring Mode (START)” on page 96 to enter Measuring Mode.

Setting Calibration Parameters (CAL SET)

The **CAL SET** menu item has 4 items: **CAL RMDR**, **CAL INT**, **CAL EXPD**, and **ESCAPE**.

1. While in User Mode, press AIR to scroll to **CAL SET**.

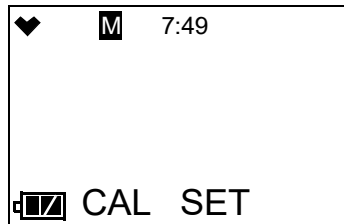

2. Press and release POWER MODE. The **CAL RMDR** menu item appears.

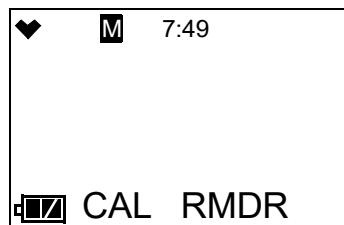

CAL RMDR

ON (factory setting): The GX-3R gives an indication at start up if it is due for calibration. The type of indication depends on the **CAL EXPD** setting (see page 80).

OFF: The GX-3R does not give an indication at start up if it is due for calibration.

1. After entering the **CAL SET** menu, press AIR to scroll to **CAL RMDR**.

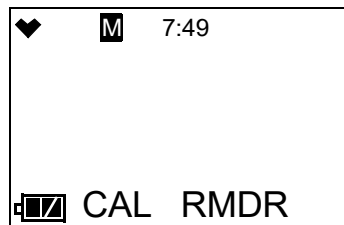

2. Press and release POWER MODE. The current setting flashes.

3. Use AIR to display the desired setting.
4. Press and release POWER MODE to save the setting and return to the **CAL RMDR** menu item.
5. See “Exiting the CAL SET Menu” on page 81 to return to User Mode.

CAL INT

This setting defines the amount of time between calibrations. The time can be set in 1 day increments. The minimum setting is **1** day and the maximum setting is **1000** days. The factory setting is **90** days.

1. After entering the **CAL SET** menu, press AIR to scroll to **CAL INT**.

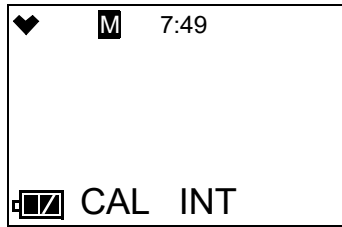

2. Press and release POWER MODE. The current setting flashes.
3. Use AIR to display the desired setting.
4. Press and release POWER MODE to save the setting and return to the **CAL INT** menu item.
5. See “Exiting the CAL SET Menu” on page 81 to return to User Mode.

CAL EXPD

This item defines what indication is given during start up when calibration is due and **CAL RMDR** is set to **ON**.

CONFIRM (factory setting): The GX-3R gives an indication at start up if calibration is past due. Press and release AIR to continue without calibrating or press and release POWER MODE to perform a calibration.

CANT USE: The GX-3R gives an indication at start up if calibration is past due. Press and release POWER MODE to enter User Mode and perform a calibration. Pressing AIR has no effect. A successful calibration must be performed in order to use the instrument.

NONE: The GX-3R gives an indication at startup if calibration is past due. If desired, press POWER MODE to perform a calibration but it is not necessary to acknowledge the calibration due indication. The warm-up sequence will continue on its own.

1. After entering the **CAL SET** menu, press AIR to scroll to **CAL EXPD**.

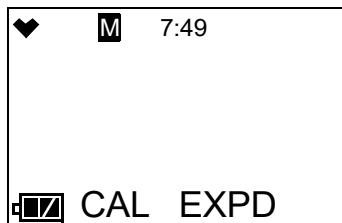

2. Press and release POWER MODE. The current setting flashes.
3. Use AIR to display the desired setting.
4. Press and release POWER MODE to save the setting and return to the **CAL EXPD** menu item.
5. See “Exiting the CAL SET Menu” on page 81 to return to User Mode.

Exiting the CAL SET Menu

1. While in the **CAL SET** menu, press AIR to scroll to **ESCAPE**.
2. Press and release POWER MODE. The instrument returns to the **CAL SET** menu item in User Mode.
3. See “Entering Measuring Mode (START)” on page 96 to enter Measuring Mode.

Setting Bump Test Parameters (BUMP SET)

The **BUMP SET** menu item has 5 items: **SETTINGS**, **BUMP.RMDR**, **BUMP INT**, **BUMP.EXPD**, and **ESCAPE**.

1. While in User Mode, press AIR to scroll to **BUMP SET**.

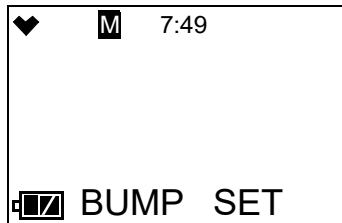

2. Press and release POWER MODE. The **SETTINGS** menu item appears.

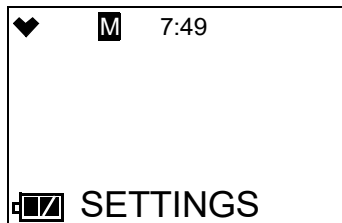

SETTINGS

The **SETTINGS** menu item has 5 items: **GAS TIME**, **CHECK**, **CAL TIME**, **AUTO CAL**, and **ESCAPE**.

1. After entering the **BUMP SET** menu, press **AIR** to scroll to **SETTINGS**.

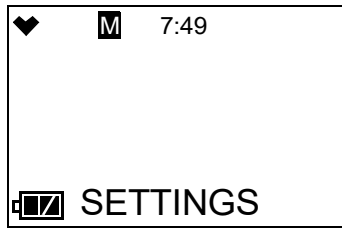

2. Press and release **POWER MODE**. The **GAS TIME** menu item appears.

GAS TIME

The **GAS TIME** is the amount of time that the instrument is exposed to gas during a bump test. The available choices are **30** seconds (factory setting), **45** seconds, **60** seconds, and **90** seconds.

1. After entering the **BUMP SET/SETTINGS** menu, press **AIR** to scroll to **GAS TIME**.

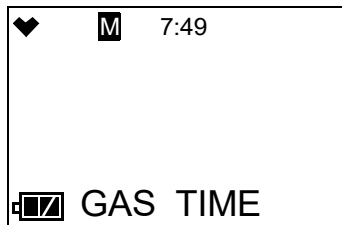

2. Press and release **POWER MODE**. The current setting flashes.
3. Use **AIR** to display the desired setting.
4. Press and release **POWER MODE** to save the setting and return to the **GAS TIME** menu item.
5. See “Exiting the SETTINGS Menu” on page 84 to return to the **BUMP SET** menu.
6. See “Exiting the BUMP SET Menu” on page 85 to return to User Mode.

CHECK

CHECK is the bump test tolerance value and is represented as a percentage of the calibration gas concentration. It is the percentage that the bump test reading can differ from the actual gas concentration and still be considered a passed bump test. If the bump test reading differs more, the bump test will fail. The available values are **10%**, **20%**, **30%**, **40%**, and **50%** (factory setting).

1. After entering the **BUMP SET/SETTINGS** menu, press **AIR** to scroll to **CHECK**.

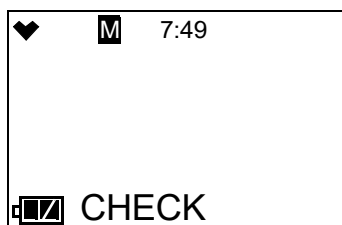

2. Press and release POWER MODE. The current setting flashes.
3. Use AIR to display the desired setting.
4. Press and release POWER MODE to save the setting and return to the **CHECK** menu item.
5. See “Exiting the SETTINGS Menu” on page 84 to return to the **BUMP SET** menu.
6. See “Exiting the BUMP SET Menu” on page 85 to return to User Mode.

CAL TIME

The **CAL TIME** is the total time the instrument is exposed to calibration gas when a bump test fails if **AUTO CAL** is set to **ON**. The bump test time is deducted from the calibration time. For example, if the **CAL TIME** is set to 90 seconds and the **GAS TIME** is set to 30 seconds, if the bump test fails, the GX-3R will only be exposed to gas for an additional 60 seconds. The available values are **90** seconds (factory setting), and **120** seconds.

1. After entering the **BUMP SET\SETTINGS** menu, press AIR to scroll to **CAL TIME**.

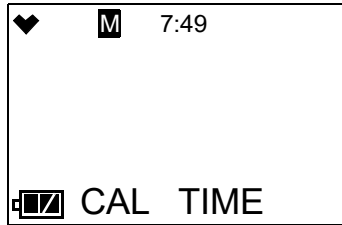

2. Press and release POWER MODE. The current setting flashes.
3. Use AIR to display the desired setting.
4. Press and release POWER MODE to save the setting and return to the **CAL TIME** menu item.
5. See “Exiting the SETTINGS Menu” on page 84 to return to the **BUMP SET** menu.
6. See “Exiting the BUMP SET Menu” on page 85 to return to User Mode.

AUTO CAL

ON (factory setting): If a bump test fails, the unit automatically begins a calibration.

OFF: If a bump test fails, the unit does not automatically begin a calibration.

1. After entering the **BUMP SET\SETTINGS** menu, press AIR to scroll to **AUTO CAL**.

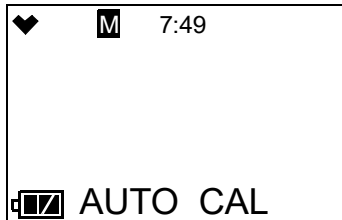

2. Press and release POWER MODE. The current setting flashes.
3. Use AIR to display the desired setting.

4. Press and release POWER MODE to save the setting and return to the **AUTO CAL** menu item.
5. See “Exiting the SETTINGS Menu” on page 84 to return to the **BUMP SET** menu.
6. See “Exiting the BUMP SET Menu” on page 85 to return to User Mode.

Exiting the SETTINGS Menu

1. While in the **BUMP SET\SETTINGS** menu, press AIR to scroll to **ESCAPE**.
2. Press and release POWER MODE. The instrument returns to the **SETTINGS** menu item of the **BUMP SET** menu.

BUMP.RMDR

ON: The GX-3R gives an indication at start up if it is due for bump testing. The type of indication depends on the **BUMP.EXPD** setting (see page 85).

OFF (factory setting): The GX-3R does not give an indication at start up if it is due for bump testing.

1. After entering the **BUMP SET** menu, press AIR to scroll to **BUMP.RMDR**.

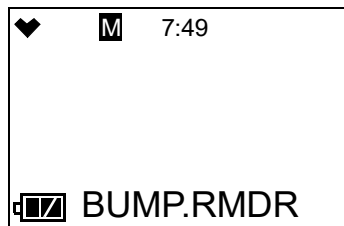

2. Press and release POWER MODE. The current setting flashes.
3. Use AIR to display the desired setting.
4. Press and release POWER MODE to save the setting and return to the **BUMP.RMDR** menu item.
5. See “Exiting the BUMP SET Menu” on page 85 to return to User Mode.

BUMP INT

This setting defines the amount of time between bump tests. The time can be set in 1 day increments. The minimum setting is **0** days and the maximum setting is **30** days (factory setting).

1. After entering the **BUMP SET** menu, press AIR to scroll to **BUMP INT**.

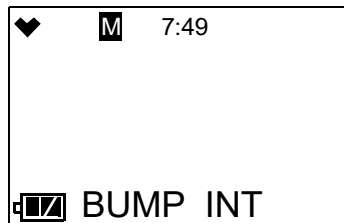

2. Press and release POWER MODE. The current setting flashes.

3. Use AIR to display the desired setting.
4. Press and release POWER MODE to save the setting and return to the **BUMP INT** menu item.
5. See “Exiting the BUMP SET Menu” on page 85 to return to User Mode.

BUMP.EXPD

This item defines what indication is given during start up when a bump test is due and **BUMP.RMDR** is set to **ON**.

CONFIRM (factory setting): The GX-3R gives an indication at start up if a bump test is past due. Press and release AIR to continue without bump testing or press and release POWER MODE to perform a bump test.

CANT USE: The GX-3R gives an indication at start up if a bump test is past due. Press and release POWER MODE to enter User Mode and perform a bump test. Pressing AIR has no effect. A successful bump test must be performed in order to use the instrument.

NONE: The GX-3R gives an indication at startup if a bump test is past due. If desired, press POWER MODE to perform a bump test but it is not necessary to acknowledge the bump test due indication. The warm-up sequence will continue on its own.

1. After entering the **BUMP SET** menu, press AIR to scroll to **BUMP.EXPD**.

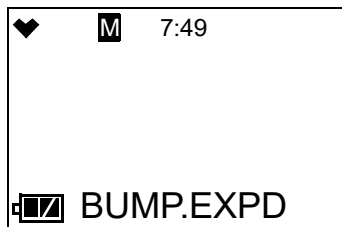

2. Press and release POWER MODE. The current setting flashes.
3. Use AIR to display the desired setting.
4. Press and release POWER MODE to save the setting and return to the **BUMP.EXPD** menu item.
5. See “Exiting the BUMP SET Menu” on page 85 to return to User Mode.

Exiting the BUMP SET Menu

1. While in the **BUMP SET** menu, press AIR to scroll to **ESCAPE**.
2. Press and release POWER MODE. The instrument returns to the **BUMP SET** menu item in User Mode.
3. See “Entering Measuring Mode (START)” on page 96 to enter Measuring Mode.

Alarm Settings (ALARM--PT)

The **ALARM--PT** menu item has 3 items: **ALARM--PT**, **DEF--ALMP**, and **ESCAPE**.

1. While in User Mode, press AIR to scroll to **ALARM--PT**.

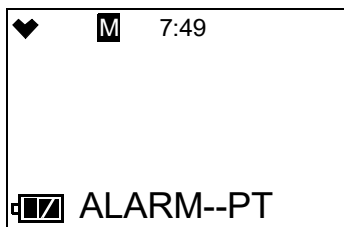

2. Press and release **POWER MODE**. The first channel displays.

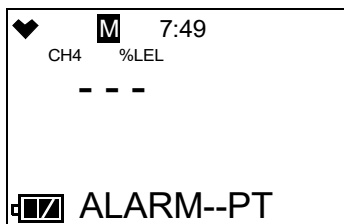

Setting the Alarm Points

1. After entering the Alarm Points menu item, press AIR to scroll through to the instrument channel whose alarm points you want to change.

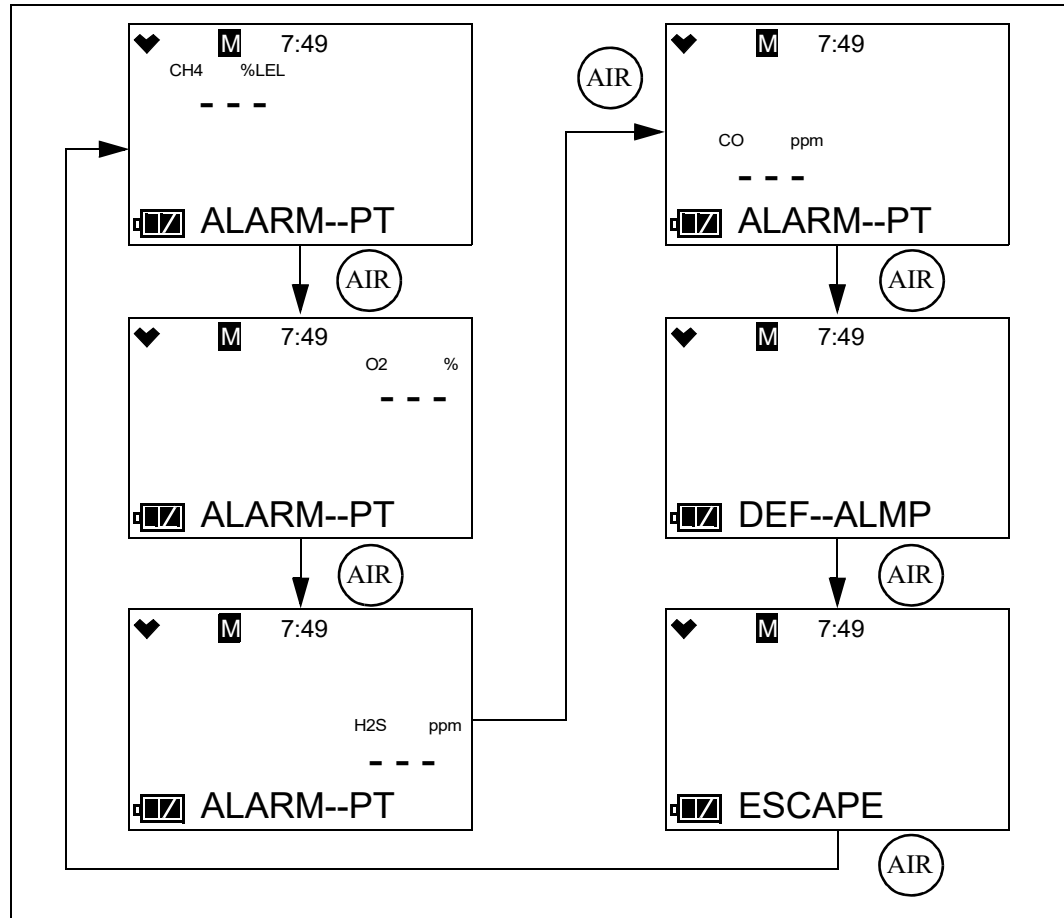

2. Press and release POWER MODE.

- The Warning setpoint for the channel flashes. In the example below, the CO channel is selected.

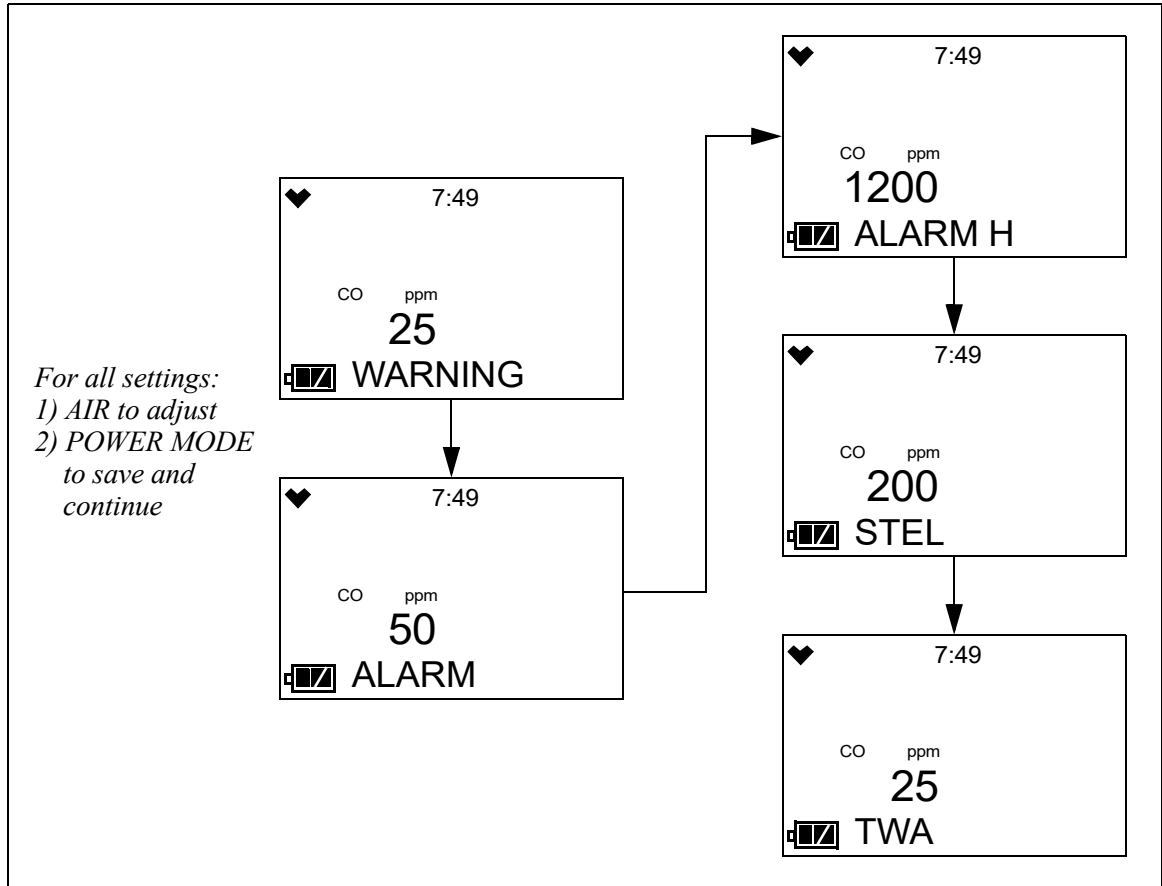

- Use AIR to adjust the Warning setpoint. Alarm setpoint limitations are shown below.

Channel	Alarm Point Limitations
Combustible Gas	$1\% \text{ LEL} \leq \text{WARNING} \leq \text{ALARM} \leq \text{ALARM H} \leq 60\% \text{ LEL}$
O ₂	<ul style="list-style-type: none"> $0.0\% \leq \text{ALARM} \leq \text{WARNING} \leq 20.0\%$ $21.8\% \leq \text{ALARM H} \leq 40.0\%$
H ₂ S	$0.5 \text{ ppm} \leq \text{WARNING} \leq \text{ALARM} \leq \text{ALARM H} \leq 200.0 \text{ ppm}$
CO	$12 \text{ ppm} \leq \text{WARNING} \leq \text{ALARM} \leq \text{ALARM H} \leq 2000 \text{ ppm}$

- Press and release POWER MODE to save the setting.
- Repeat Step 4 and Step 5 for the Alarm, Alarm H, STEL (CO and H₂S only), and TWA (CO and H₂S only) settings.
- The instrument returns to the channel selection screen.
- Repeat Step 1 - Step 7 to change the alarm points for other channels.
- See “ESCAPE” on page 89 to return to User Mode.

Defaulting the Alarm Points

Defaulting the alarm points defaults them back to factory settings as outlined in Table 1 on page 11 or to the settings saved in the **SAVE-AP** menu item in Gas Select Mode if you have performed a **SAVE-AP** operation.

1. After entering the Alarm Points menu item, press AIR to scroll to **DEF-ALMP**.

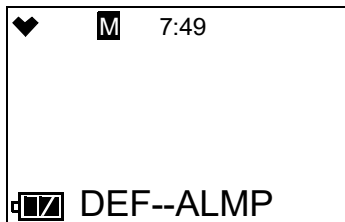

2. Press POWER MODE to enter the **DEF-ALMP** menu item.
3. Press POWER MODE to perform an alarm default. Press AIR to return to the **DEF-ALMP** menu item.
4. The instrument asks if you're sure you want to default the alarm points. Press POWER MODE to default the alarm points. Press AIR to return to the **DEF-ALMP** menu item.
5. See "ESCAPE" on page 89 to return to User Mode.

ESCAPE

1. While in the **ALARM-P** menu, press AIR to scroll to **ESCAPE**.
2. Press and release POWER MODE. The instrument returns to the **ALARM--PT** menu item.
3. See "Entering Measuring Mode (START)" on page 96 to enter Measuring Mode.

Updating the Lunch Break Setting (LUNCH)

OFF (factory setting): The GX-3R automatically starts new TWA and PEAK reading collection and resets the time in operation at startup.

ON: The Lunch Break Screen displays during startup. From this screen, you can choose to continue accumulating TWA and PEAK readings and the time in operation from the last time the GX-3R was used or start collecting new readings and reset the time in operation.

1. While in User Mode, press AIR to scroll to **LUNCH**.

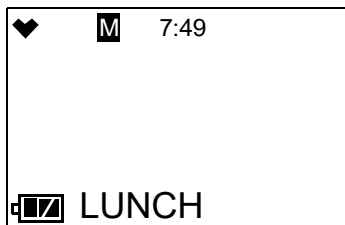

2. Press and release POWER MODE. The current setting flashes.
3. Use AIR to display the desired setting.

4. Press and release POWER MODE to save the setting and return to the **LUNCH** menu item.
5. See “Entering Measuring Mode (START)” on page 96 to enter Measuring Mode.

Setting the Confirmation Beep and Non-Compliance Indicator (BEEP)

The **BEEP** menu item has 3 items: **BEEP SEL**, **BEEP INT**, and **ESCAPE**.

1. While in User Mode, press AIR to scroll to **BEEP**.

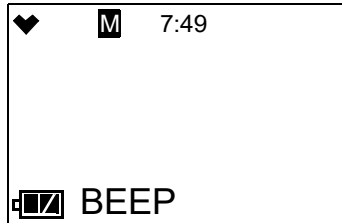

2. Press and release POWER MODE. The **BEEP SEL** menu item appears.

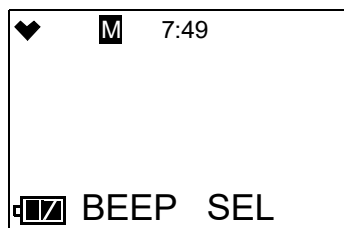

BEEP SEL

BEEP SEL defines what kind of confirmation or non-compliance indication you want to occur in Measuring Mode. The available choices are:

OFF (factory setting): The GX-3R does not provide a confirmation alert or non-compliance indicator.

LED: The GX-3R's LEDs double flash as often as defined by the **BEEP INT** parameter to verify that the instrument is operating.

BUZZER: The GX-3R's buzzer double beeps as often as defined by the **BEEP INT** parameter to verify that the instrument is operating.

LED+BUZZ: The GX-3R's LEDs double flash and the buzzer double beeps as often as defined by the **BEEP INT** parameter to verify that the instrument is operating.

BUMP/CAL: If a bump test or a calibration is due and if **BUMP.EXPD** or **CAL EXPD** is set to **CONFIRM** or **NONE**, the GX-3R's LEDs double flash as often as defined by the **BEEP INT** parameter to indicate a non-compliance. Once a bump test or calibration (depending on which is due) is done, the LEDs stop flashing.

ALMALRT: If the instrument goes into any gas alarm, the LEDs double flash as often as defined by the **BEEP INT** parameter to indicate a non-compliance. Once a successful bump test or calibration is done, the LEDs stop flashing.

NOTE: Depending on the **Need to get Bump Log** setting (only accessed via SDM-3R program), a data download may also be needed to clear the non-compliance.

B/C/ALM: The LEDs double flash to indicate a non-compliance if any of the following happens.

- a. **BUMP.EXPD** is set to **CONFIRM** or **NONE** and a bump test is due (cleared by successful bump test).
- b. **CAL EXPD** is set to **CONFIRM** or **NONE** and a calibration is due (cleared by successful calibration).
- c. The instrument goes into any gas alarm (cleared by successful bump test or calibration).

NOTE: Depending on the **Need to get Bump Log** setting (only accessed via SDM-3R program), a data download may also be needed to clear the gas alarm non-compliance.

1. While in the **BEEP** menu, press AIR to scroll to **BEEP SEL**.

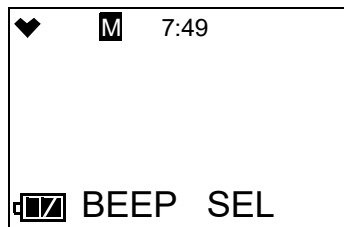

2. Press and release POWER MODE. The current setting flashes.
3. Use AIR to display the desired setting.
4. Press and release POWER MODE to save the setting and return to the **BEEP SEL** menu item.
5. See “ESCAPE” on page 92 to return to User Mode.

BEEP INT

The **BEEP INT** parameter defines how often the confirmation alert or non-compliance indicator selected in **BEEP SEL** occurs. This setting only applies if the **BEEP SEL** parameter is set to something other than **OFF**. The available choices are **0.5** minutes and **1-99** minutes in 1 minute increments. The factory setting is **5** minutes.

1. While in the **BEEP** menu, press AIR to scroll to **BEEP INT**.

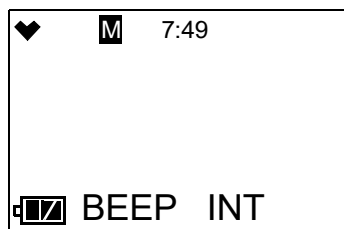

2. Press and release POWER MODE. The current setting flashes.

3. Use AIR to display the desired setting.
4. Press and release POWER MODE to save the setting and return to the **BEEP INT** menu item.
5. See “ESCAPE” on page 92 to return to User Mode.

ESCAPE

1. While in the **BEEP** menu, press AIR to scroll to **ESCAPE**.
2. Press and release POWER MODE. The instrument return to the **BEEP** menu item.
3. See “Entering Measuring Mode (START)” on page 96 to enter Measuring Mode.

Updating the Backlight Time (BL TIME)

This setting defines how long the LCD backlight stays on when you press any button. The minimum setting is **OFF**; the maximum setting is **255** seconds. The factory setting is **30** seconds.

1. While in User Mode, press AIR to scroll to **BL TIME**.

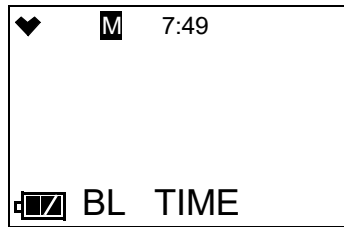

2. Press and release POWER MODE. The current setting flashes.
3. Use AIR to display the desired setting.
4. Press and release POWER MODE to save the setting and return to the **BL TIME** menu item.
5. See “Entering Measuring Mode (START)” on page 96 to enter Measuring Mode.

Turning the Key Tone On/Off (KEY TONE)

ON (factory setting): The instrument beeps when a button is pressed.

OFF: The instrument does not beep when a button is pressed.

1. While in User Mode, press AIR to scroll to **KEY TONE**.

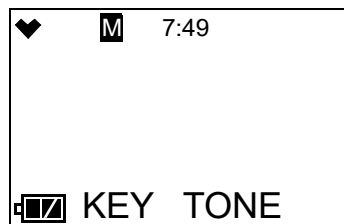

2. Press and release POWER MODE. The current setting flashes.

3. Use AIR to display the desired setting.
4. Press and release POWER MODE to save the setting and return to the **KEY TONE** menu item.
5. See “Entering Measuring Mode (START)” on page 96 to enter Measuring Mode.

Display Mode Items (DISP SET)

OFF: LIST, USER ID, and STN ID items do not appear in Display Mode.

ON (factory setting): LIST item appears in Display Mode. **USER ID** and **STATION ID** screens appear in Display Mode if **ID DISP** in Maintenance Mode is also set to **ON** (factory setting is **OFF**).

1. While in User Mode, press AIR to scroll to **DISP SET**.

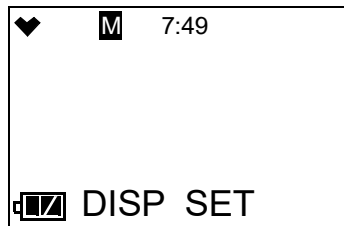

2. Press and release POWER MODE. The current setting flashes.
3. Use AIR to display the desired setting.
4. Press and release POWER MODE to save the setting and return to the **DISP SET** menu item.
5. See “Entering Measuring Mode (START)” on page 96 to enter Measuring Mode.

Zero Suppression (ZERO SUP)

This menu item only appears if **ZSUP.DISP** is set to **ON** in Maintenance Mode (factory setting is **OFF**).

The **ZERO SUP** setting is not intended for field adjustment. The default setting for each sensor is **ON**.

Sensor	Zero Suppression Value
Combustible Gas	2% LEL
O ₂	0.5% volume
H ₂ S	0.3 ppm
CO	2 ppm

Zero Follower (ZERO.FLWR)

This menu item only appears if **ZFLW.DISP** is set to **ON** in Maintenance Mode (factory setting is **OFF**).

The **ZERO.FLWR** setting is not intended for field adjustment. The default setting is **ON**. The oxygen channel does not support zero follower functionality.

Setting the Date/Time (DATE)

1. From the main menu, place the cursor next to **DATE**.

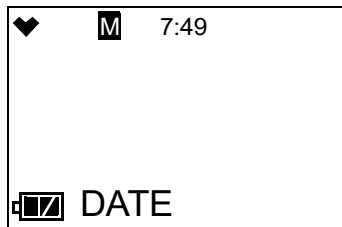

2. Press and release **POWER MODE**. The date and time display with the year flashing.

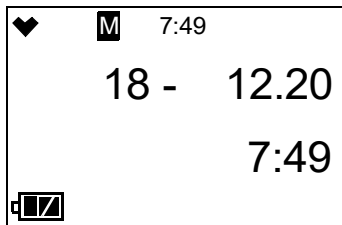

3. Use **AIR** to display the desired year.
4. Press and release **POWER MODE** to save the setting. The month setting flashes.
5. Repeat Step 3 and Step 4 to enter the month, day, hours, and minutes settings. The date and time are saved and the instrument returns to the **DATE** menu item.
6. See “Entering Measuring Mode (START)” on page 96 to enter Measuring Mode.

Turning the Password On/Off (PASSWORD)

ON: The GX-3R prompts you for a password when you enter User Mode. The factory-set password is **0405** but it can be changed as desired.

OFF (factory setting): No password is required to enter User Mode.

1. While in User Mode, press AIR to scroll to **PASSWORD**.

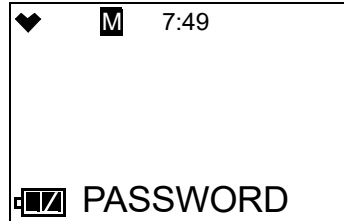

2. Press and release POWER MODE. The current setting flashes.
3. Use AIR to display the desired setting.
4. If you selected **OFF**, press and release POWER MODE to save the setting and return to the **PASSWORD** item in User Mode.
If you selected **ON**, continue with Step 5.
5. Press and release POWER MODE. The Set Password Screen appears. The current password appears and the first digit flashes.

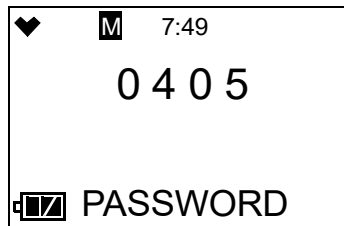

6. Use AIR to display a number from 0 to 9.
7. Press and release POWER MODE to enter the selection and advance to the next number. To go back a number, press and hold AIR and POWER MODE for a few seconds.
8. Repeat Step 6 and Step 7 to select the remaining numbers. When you press and release POWER MODE to enter the last number, the password is saved and you return to the **PASSWORD** item in User Mode.
9. See “Entering Measuring Mode (START)” on page 96 to enter Measuring Mode.

Viewing the ROM/SUM (ROM/SUM)

The **ROM/SUM** screen shows the instrument's firmware version and firmware checksum.

1. While in User Mode, press AIR to scroll to **ROM/SUM**.

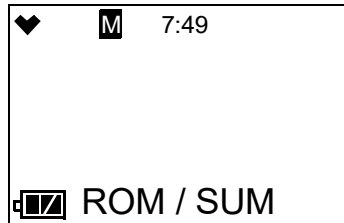

2. Press and release **POWER MODE**. The screen cycles through the main board's ROM/SUM and the sensor board's ROM/SUM. The ROM is the top value and the SUM is the bottom value.

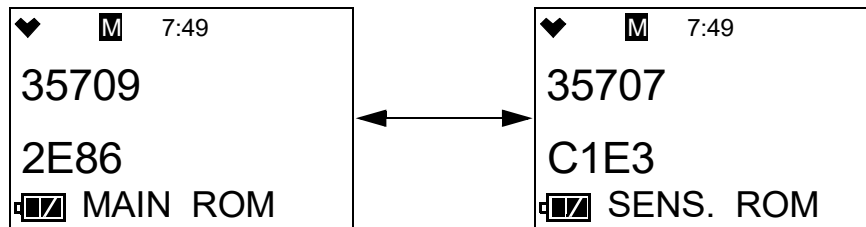

3. Press and release **POWER MODE** to return to the **ROM/SUM** menu item in User Mode.
4. See “Entering Measuring Mode (START)” on page 96 to enter Measuring Mode.

Entering Measuring Mode (START)

1. While in User Mode, press AIR to scroll to **START**.

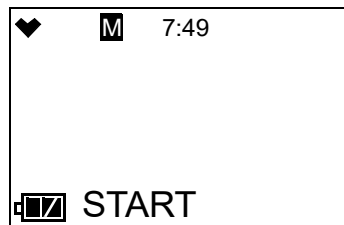

2. Press and release **POWER MODE**. The instrument begins its warmup sequence.

Chapter 6: Maintenance

Overview

This chapter describes troubleshooting procedures for the GX-3R. It also includes procedures for instrument cleaning, recharging the batteries, and replacing various consumable parts.

WARNING: *If the enclosure is damaged it shall be repaired before further use.*

WARNING: *RKI Instruments, Inc. recommends that service, calibration, and repair of RKI instruments be performed by personnel properly trained for this work. Replacing sensors and other parts with original equipment does not affect the intrinsic safety of the instrument.*

WARNING: *This product is an explosion-proof product and is not to be disassembled or modified with the exception of specified parts.*

Troubleshooting

Table 15 describes error messages, symptoms, probable causes, and recommended action for problems you may encounter with the GX-3R.

Table 15: Troubleshooting the GX-3R

Symptoms	Probable Causes	Recommended Action
<ul style="list-style-type: none">The LCD is blank.	<ul style="list-style-type: none">The unit may have been turned off.The batteries may need to be recharged.	<ol style="list-style-type: none">To turn on the unit, press and briefly hold POWER MODE.If the unit does not turn on, recharge the batteries.If the difficulties continue, contact RKI Instruments, Inc. for further instruction.
<ul style="list-style-type: none">The LCD shows abnormally high or low readings but other gas detection instruments do not.	<ul style="list-style-type: none">The filters may need to be replaced.The GX-3R may need to be recalibrated.The sensor for the affected channel(s) may need replacement.	<ol style="list-style-type: none">Replace the filters.Recalibrate the unit.If the difficulties continue, replace the sensor for the affected channel(s) and calibrate the affected channel(s).If the difficulties continue, contact RKI Instruments, Inc. for further instruction.

Table 15: Troubleshooting the GX-3R

Symptoms	Probable Causes	Recommended Action
<ul style="list-style-type: none"> • Calibration fails. 	<ul style="list-style-type: none"> • The calibration values may not match the cylinder gas concentrations. • The charcoal filter or charcoal half of the dual filter is saturated causing an elevated CO reading. • The sample gas is not reaching the sensors because of a bad connection. • The calibration cylinder may be out of gas or is outdated. • The sensor for the affected channel(s) may need replacement. 	<ol style="list-style-type: none"> 1. Make sure the GX-3R has been properly set up for calibration. 2. Change the charcoal filter or the dual filter. 3. Check all calibration tubing for leaks or for any bad connections. 4. Verify that the calibration cylinder contains an adequate supply of fresh test sample. 5. If the fail condition continues, replace the sensor(s). 6. If the difficulties continue, contact RKI Instruments, Inc. for further instruction.
<ul style="list-style-type: none"> • Heart symbol at the top of the screen becomes steadily on or disappears 	<ul style="list-style-type: none"> • A microprocessor error has occurred. 	<ul style="list-style-type: none"> • Contact RKI Instruments, Inc. for further instruction.
<ul style="list-style-type: none"> • Charge LED alternates between green and orange 	<ul style="list-style-type: none"> • Charging environment is outside the allowed 0 - 40°C charging temperature range. 	<ul style="list-style-type: none"> • Move the charger to a location that is within the allowed 0 - 40°C charging temperature range.

Instrument Cleaning

Clean the GX-3R with a cloth dampened with water if it becomes excessively dirty. Do not use alcohol or other cleaning solvents.

Recharging the Batteries

AVERTISSEMENT: *Do not charge batteries in a hazardous location. Do not charge the unit with a non-genuine charger. Charge only with RKI charger p/n 49-0133 or 49-0134. Use of other chargers will void the warranty.*

AVERTISSEMENT: *Ne chargez pas les batteries dans un endroit dangereux. Ne chargez pas l'appareil avec un chargeur qui n'est pas d'origine. Chargez uniquement avec le chargeur RKI réf. 49-0133 ou 49-0134. L'utilisation d'autres chargeurs annulera la garantie.*

Recharge the batteries when the battery icon indicates that the unit is in low battery warning. When in low battery warning, the lowest battery level indication bar disappears and the battery icon flashes.

1. Make sure the GX-3R is off.
2. Plug the AC adapter into an electrical outlet.
3. Plug the charging jack straight into the GX-3R's charging socket from the top. When properly connected, a green LED turns on at the top of the GX-3R.

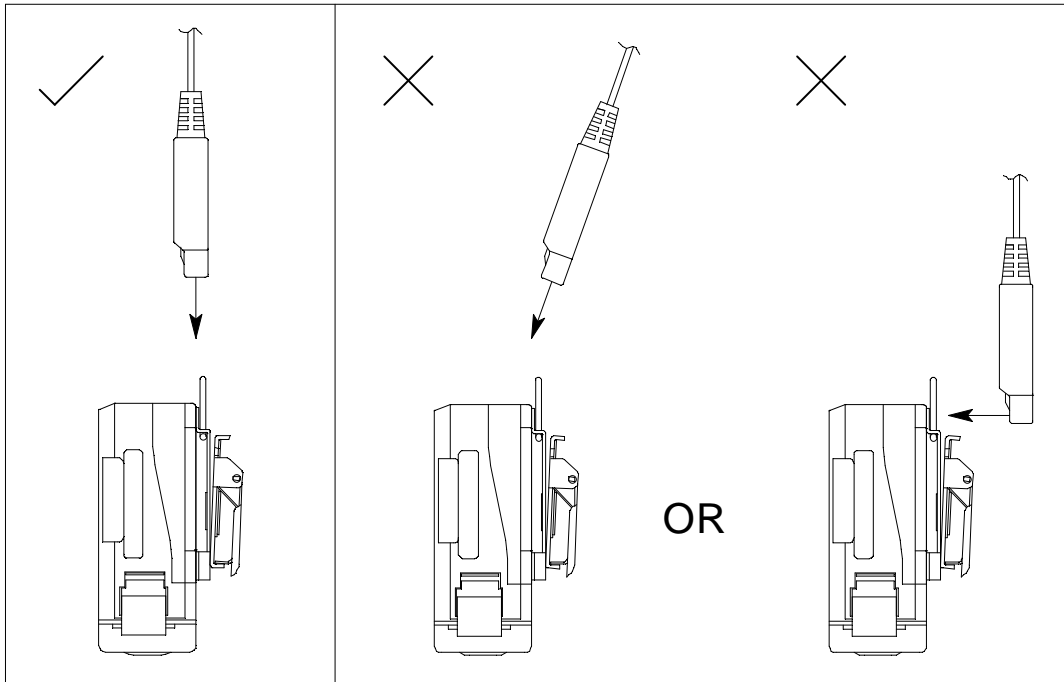

Figure 11: Connecting the Charging Cable

4. The LED at the top of the GX-3R turns orange while charging. When a full charge has been reached, approximately 3 hours, the LED turns green.

5. Pull the charging jack straight out of the GX-3R's charging socket.

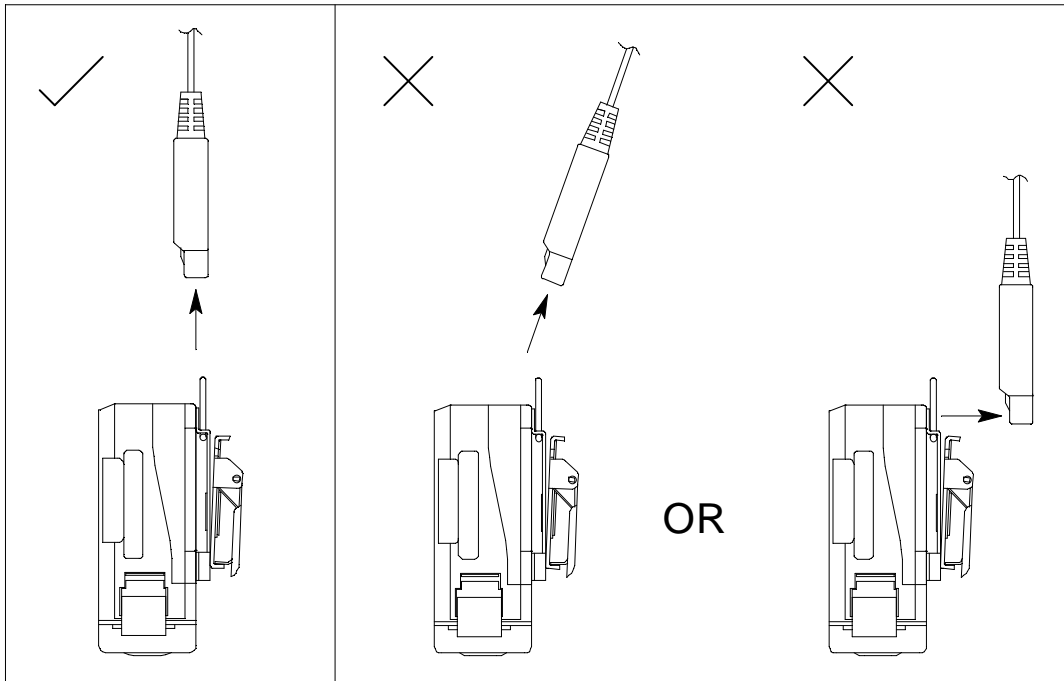

Figure 12: Removing the Charging Cable

6. Turn on the GX-3R and confirm that it starts up.

Replacing the Buzzer Cover

The buzzer cover may need to be replaced if it becomes saturated or clogged with particles.

1. Remove the rubber boot from the GX-3R.
2. Peel off the old buzzer cover located between the AIR and POWER MODE buttons.
3. If necessary, clean any remaining residue from the case.
4. Peel the backing off of the new buzzer cover.

5. Install the new buzzer cover between the AIR and POWER MODE buttons as shown below.

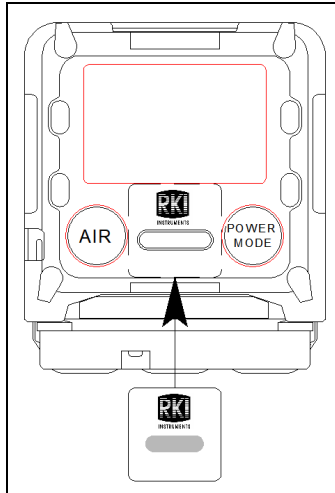

Figure 13: Buzzer Cover Replacement

6. Reinstall the rubber boot.

Replacing the Sensor Filters

CAUTION: *The buzzer cover, sensors, and filters are the only user-serviceable parts in the GX-3R. Do not replace or modify any other part.*

Combustible Gas Sensor Filter

The H₂S filter disk is dark red in color and although it may darken over time, its color is not indicative of remaining filter life. The H₂S filter disk can absorb H₂S for 33 ppm hours and should be replaced after that much exposure. With this many ppm hours of absorption, the H₂S filter disk should be replaced after 80 minutes of exposure to 25 ppm H₂S. This equates to replacing the H₂S filter disk after 40 2-minute calibrations with a cylinder containing 25 ppm H₂S. If H₂S exists in the monitoring environment, the H₂S filter disk will have to be replaced more frequently.

Dual CO/H₂S Sensor Filter

The dual CO/H₂S sensor has a half black/half white filter installed over it. The filter should be replaced if you notice either 1) unexplained CO readings or 2) For users with a 1 ppm H₂S alarm setpoint: a drift on the H₂S channel's zero reading, unexplained H₂S readings, the filter appears dirty, or every 6 months (whichever is sooner).

CO-Only Sensor Filter

A black charcoal filter is installed over CO-only sensors. The filter should be replaced if you notice unexplained CO readings.

H₂S-Only Sensor Filter

A white humidity filter is installed over H₂S-only sensors. The filter absorbs humidity in the sampling environment to prevent unstable readings around 0 ppm H₂S. For users with a 1 ppm H₂S alarm setpoint, the filter should be replaced if you notice: a drift on the H₂S channel's zero reading, unexplained H₂S readings, the filter appears dirty, or every 6 months (whichever is sooner). For users with a 2 ppm or higher H₂S alarm setpoint, the filter does not necessarily ever need to be replaced.

Replacement Procedure

1. Verify that the GX-3R is off.
2. Turn the GX-3R upside down.
3. Use a small Phillips screwdriver to unscrew the two screws holding the bottom cover to the rest of the GX-3R's case. Only unscrew them until the heads are flush with the edge of the bottom cover.
4. Using a small flat blade screwdriver, gently pry each side of the bottom cover away from the rest of the GX-3R's case.
5. Remove the bottom cover from the rest of the GX-3R's case.
6. Remove the filter gasket/sensor retainer assembly.
7. Remove the filter gasket/hydrophobic dust filter assembly.
8. Gently pry out the filter you want to replace.
9. Install the new filters.
 - a. Dark red H₂S scrubber disk for combustible gas sensor: The brown side of the filter case should face toward the GX-3R.
 - b. Black and white combo filter for CO/H₂S dual sensor: The red side of the filter case should face toward the GX-3R. The black filter material should face the edge of the GX-3R while the white filter material should face the H₂S scrubber disk.
 - c. Black filter for CO-only sensor: The red side of the filter case should face toward the GX-3R.
 - d. White filter for H₂S-only sensor: The white side of the filter case should face toward the GX-3R.

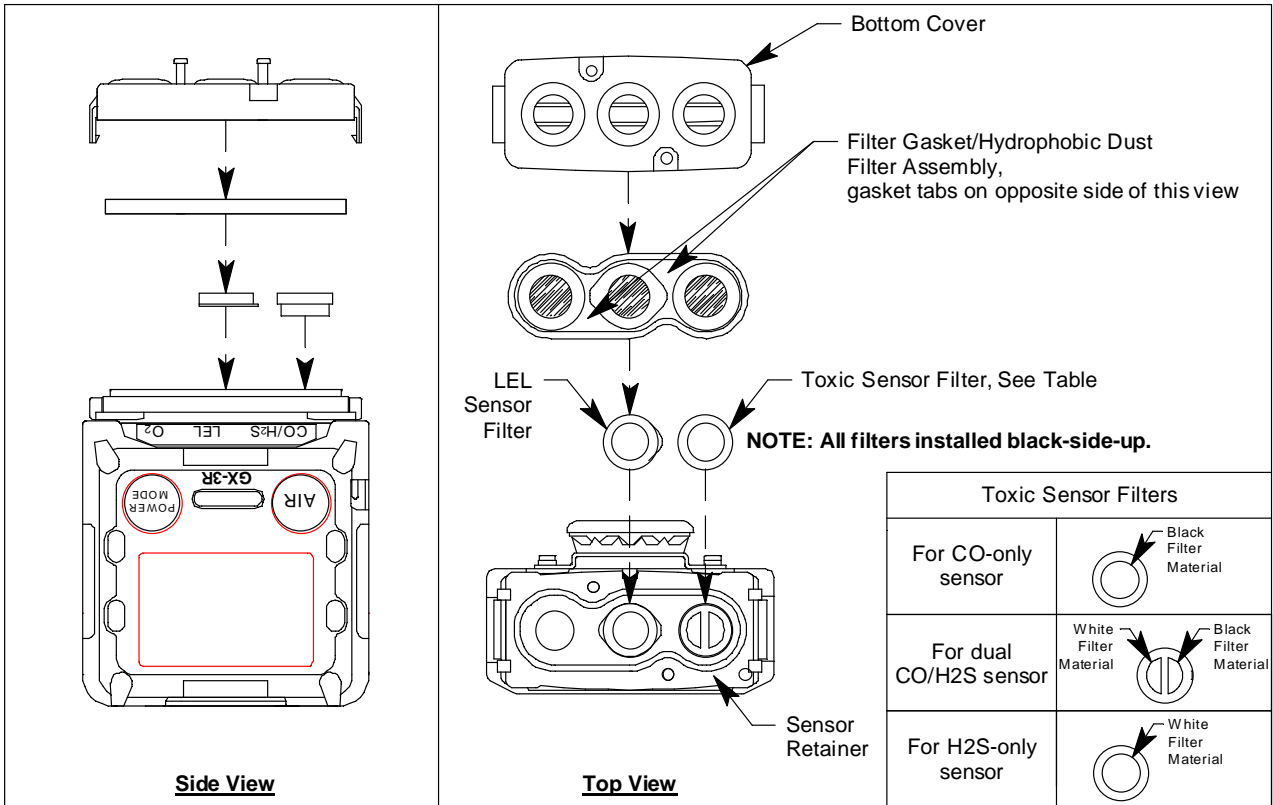
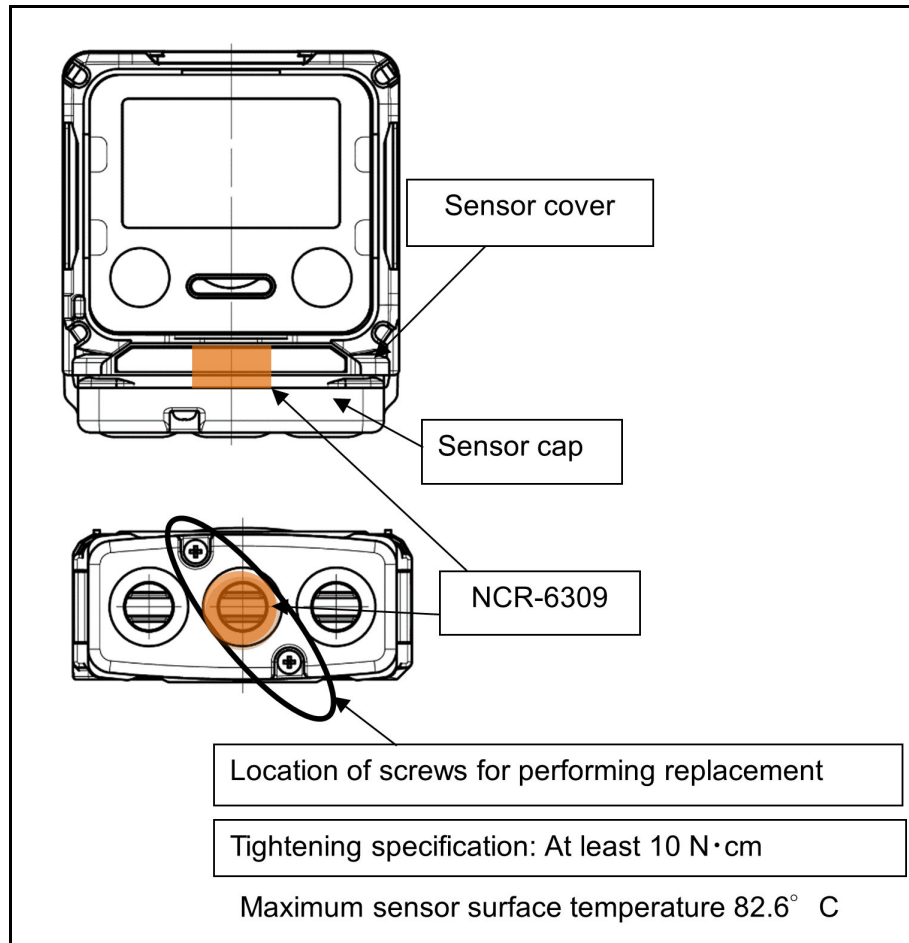

Figure 14: Replacing the Sensor Filters

10. Reinstall the filter gasket/hydrophobic dust filter assembly onto the sensor retainer. The gasket tabs face down.
11. Reattach the bottom cover to the GX-3R. Push it onto the GX-3R until it snaps into place.

12. Reinstall the two screws that were loosened in Step 3. Tighten the screws to at least 10 Ncm.



13. Perform a bump test as described on page 60 to confirm good operation.

Replacing the Hydrophobic Dust Filter

Some GX-3Rs have a hydrophobic dust filter that is not attached to the filter gasket. When replacing the hydrophobic dust filter on one of these GX-3Rs, remove the filter and the gasket and replace it with a filter gasket/hydrophobic dust filter assembly.

1. Verify that the GX-3R is off.
2. Turn the GX-3R upside down.
3. Use a small Phillips screwdriver to unscrew the two screws holding the bottom cover to the rest of the GX-3R's case. Only unscrew them until the heads are flush with the edge of the bottom cover.
4. Using a small flat blade screwdriver, gently pry each side of the bottom cover away from the rest of the GX-3R's case.
5. Remove the bottom cover from the rest of the GX-3R's case. The filter gasket/sensor retainer assembly may come out.

6. Remove the filter gasket/hydrophobic dust filter assembly.
7. Install the new filter gasket/hydrophobic dust filter assembly with the gasket tabs facing down.

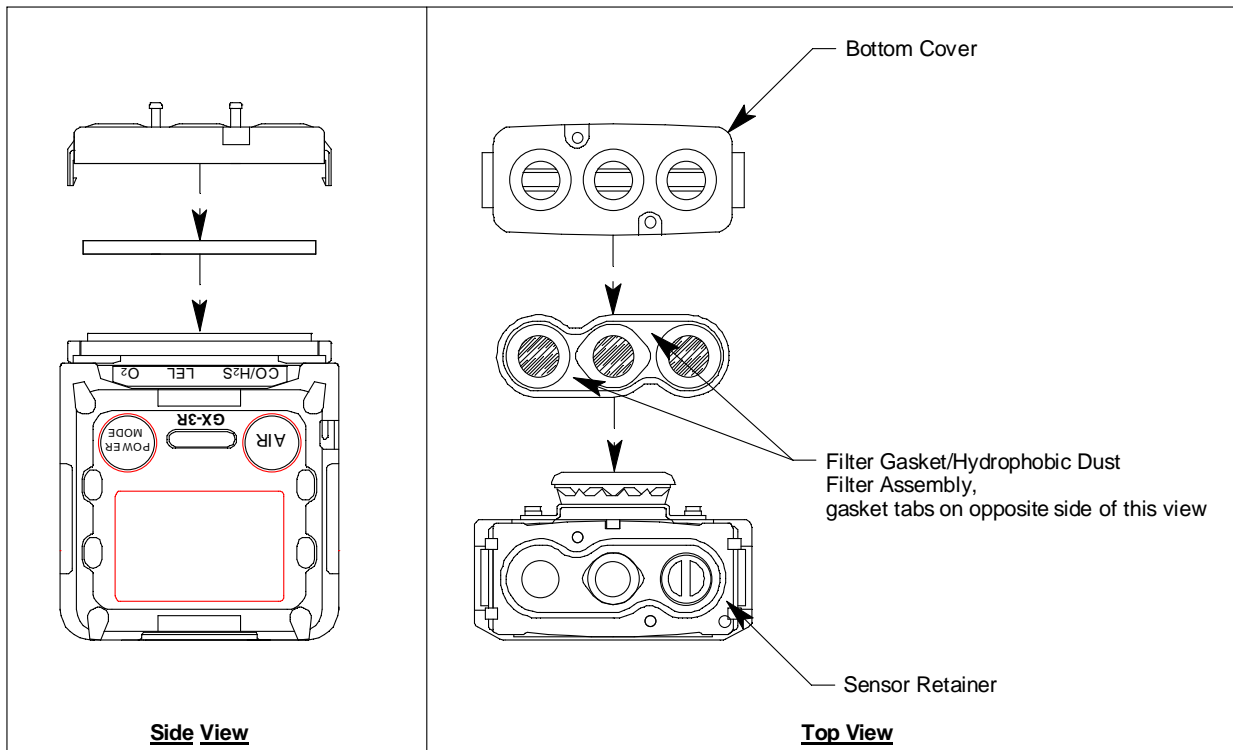
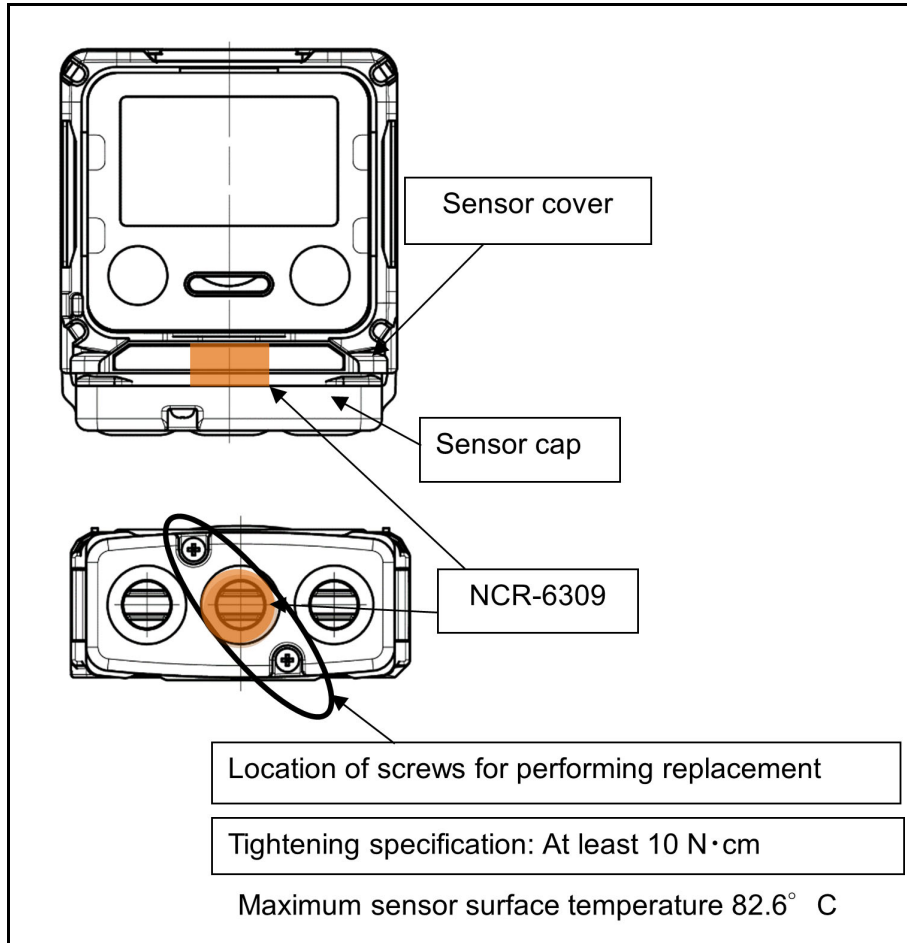

Figure 15: Replacing the Hydrophobic Dust Filter

8. Reattach the bottom cover to the GX-3R. Push it onto the GX-3R until it snaps into place.

9. Reinstall the two screws that were loosened in Step 3. Tighten the screws to at least 10 Ncm.



Replacing a Sensor

WARNING: *This product integrates a sensor having flameproof construction. If assembly is not performed as specified, explosion protection performance will be compromised. When replacing the sensor and filter, properly install genuine parts and torque to specification.*

CAUTION: *The CO and H₂S sensors contain an electrolyte solution. If contact with the electrolyte occurs, wash the area immediately.*

CAUTION: *The buzzer cover, sensors, and filters are the only user-serviceable parts in the GX-3R. Do not replace or modify any other part.*

1. Verify that the GX-3R is off.
2. Turn the GX-3R upside down.
3. Use a small Phillips screwdriver to unscrew the two screws holding the bottom cover to the rest of the GX-3R's case. Only unscrew them until the heads are flush with the edge of the bottom cover.
4. Using a small flat blade screwdriver, gently pry each side of the bottom cover away from the rest of the GX-3R's case.
5. Remove the filter gasket/sensor retainer assembly from the GX-3R. The sensors will be exposed.
6. Locate the sensor you want to replace and remove it from its socket.
7. Carefully insert the replacement sensor in the correct socket. Be sure that the new sensor is installed in the same position as the old sensor and that it is aligned correctly. The toxic and oxygen sensors have slots to orient the sensor. The combustible gas sensor has tabs to orient the sensor. Do not force a sensor into its slot.

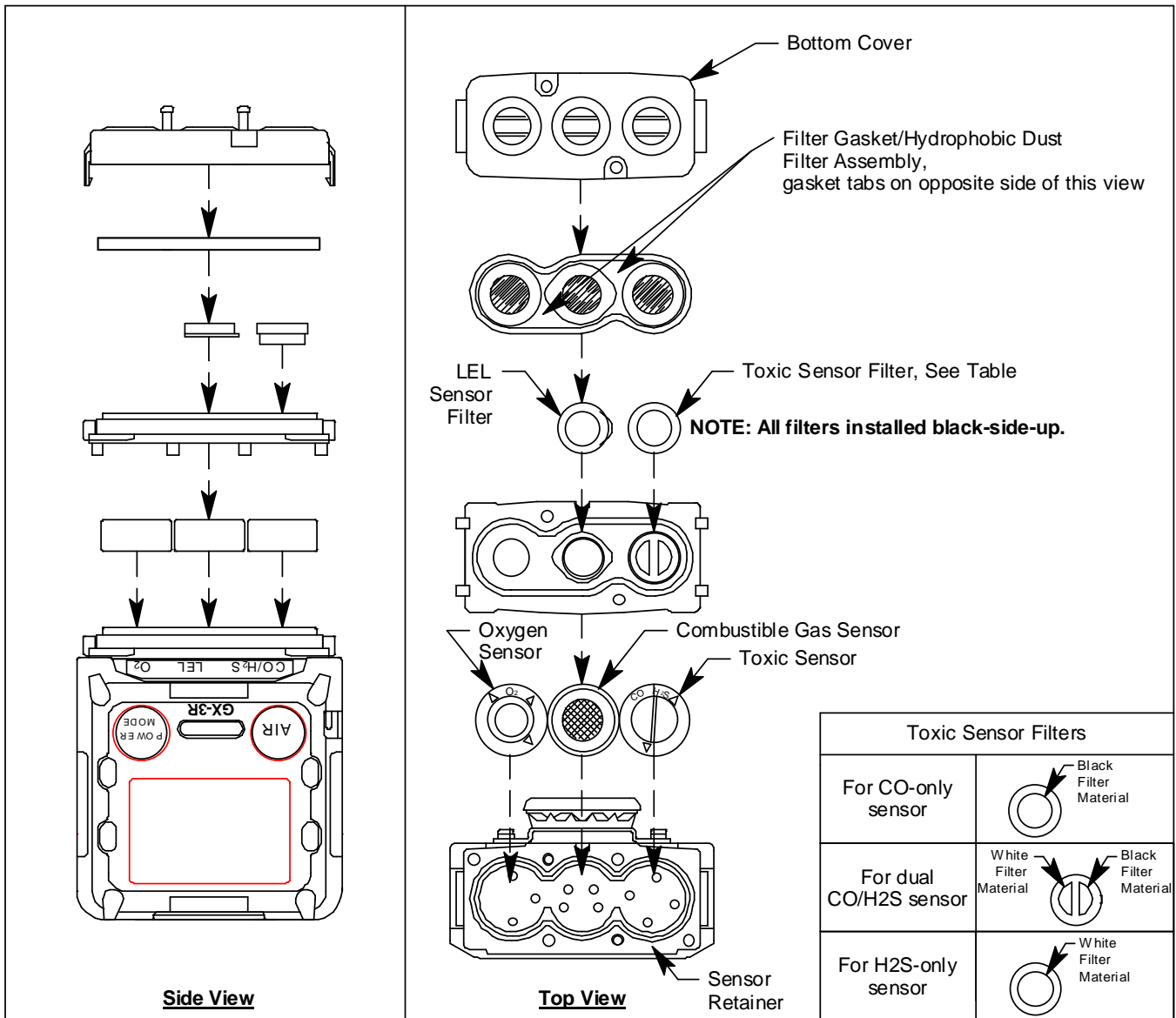
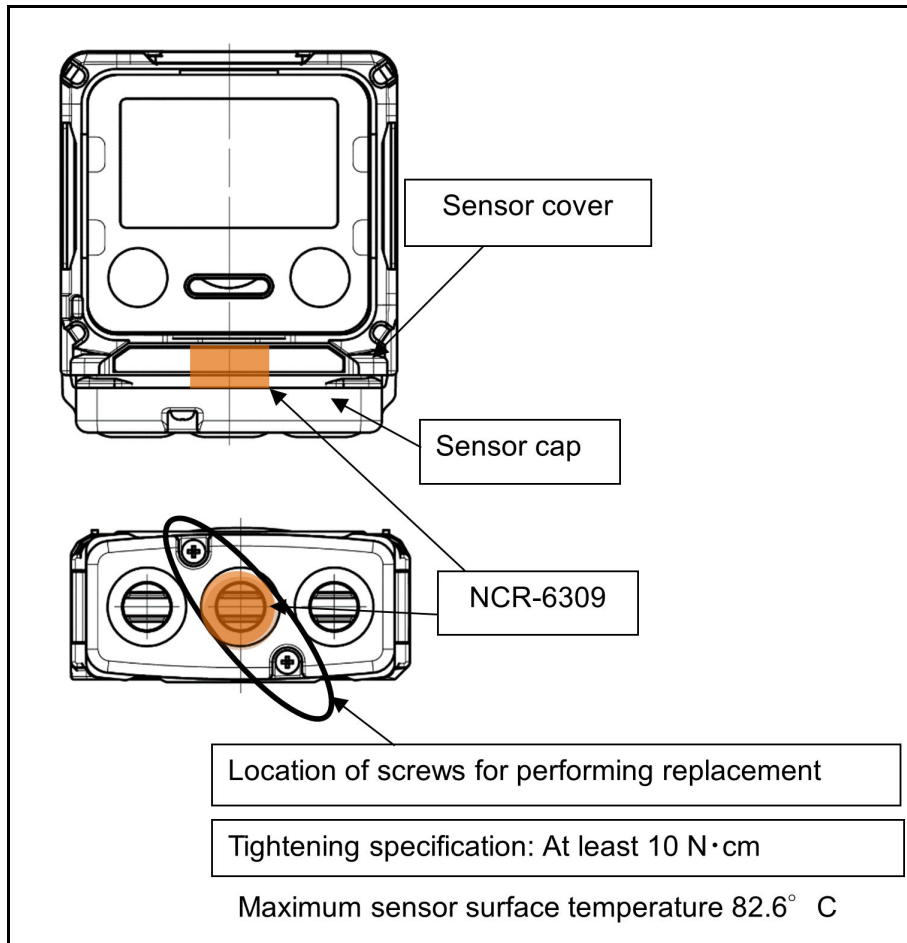

Figure 16: Replacing a Sensor

8. If your instrument has a factory installed dummy sensor, ensure that it is still installed correctly. Make sure that the flat side is facing away from the GX-3R.
9. Reinstall the filter gasket/sensor retainer assembly. The black and white filter goes over the CO/H₂S sensor with the black half of the filter facing the edge of the GX-3R. Be sure the filter gasket/sensor retainer is oriented correctly.
10. If the filter gasket/hydrophobic dust filter assembly came out, reinstall it with the gasket tabs facing down.
11. Reattach the bottom cover to the GX-3R. Push it onto the GX-3R until it snaps into place.

12. Reinstall the two screws that were loosened in Step 3. Tighten the screws to at least 10 Ncm.



13. Calibrate the new sensors as described on page 67. If a new H₂-compensated CO sensor was installed, you need to calibrate with CO and set the H₂ response.

Replacing the Battery Board

Replace the battery board when the GX-3R doesn't hold a charge anymore.

1. Verify that the GX-3R is off.
2. Remove the rubber boot, if installed.
3. Place the GX-3R LCD-side-down.

4. Unscrew the 4 screws that hold the two case halves together. The alligator or belt clip does not need to be removed.

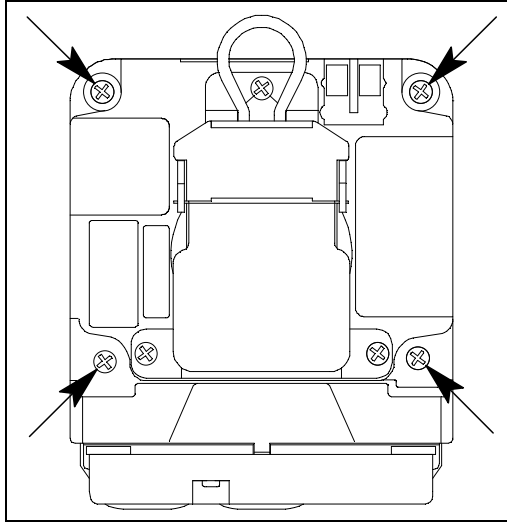

Figure 17: Removing Case Screws

5. Separate the two case halves. You may need to pry them apart.
6. The rear half of the case has the battery board.
7. Unscrew the 3 screws that hold the battery board.

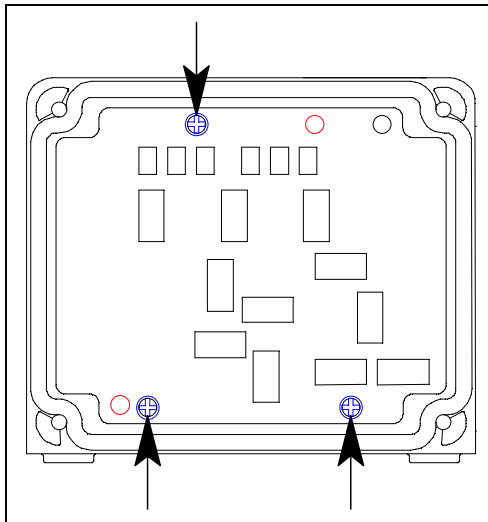

Figure 18: Removing Battery Board Screws

8. Gently remove the battery board. A black rectangular gasket may come out with the battery board.

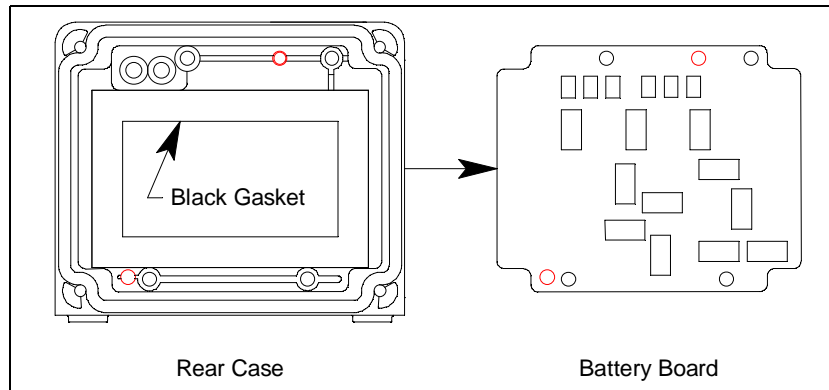

Figure 19: Removing the Battery Board

9. Place the black rectangular gasket flat in the rear case.
10. Place the new battery board battery-side-down in the rear case. The case has protrusions that fit in holes on the battery board.

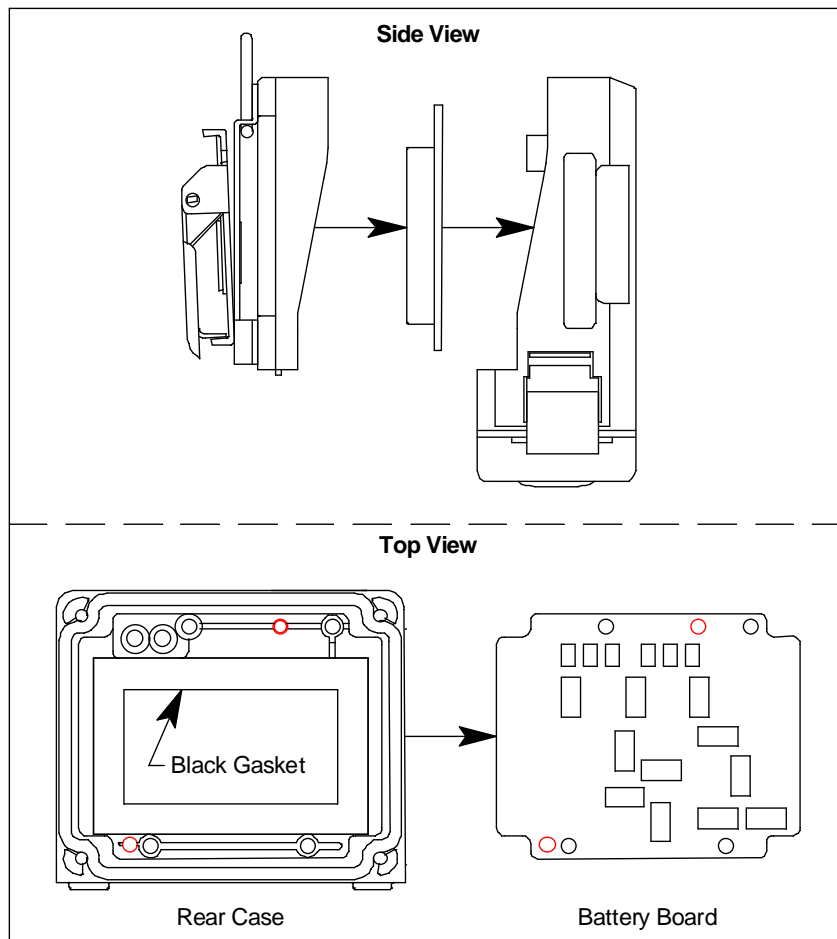

Figure 20: Reinstalling the Battery Board

11. Secure the battery board using the screws removed in Step 7.

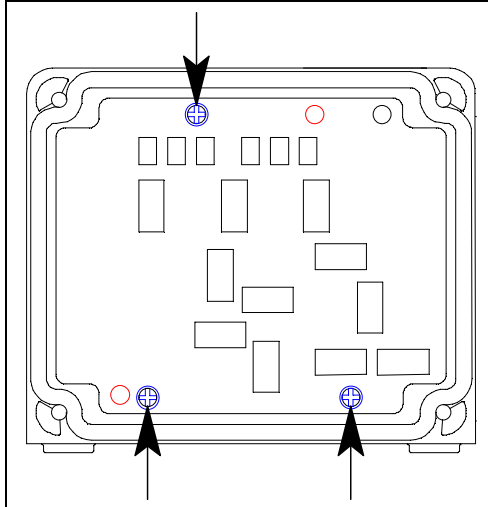

Figure 21: Reinstalling Battery Board Screws

12. Be sure the gasket along the edge of the rear case is seated correctly. The flat side of the gasket faces away from the case.

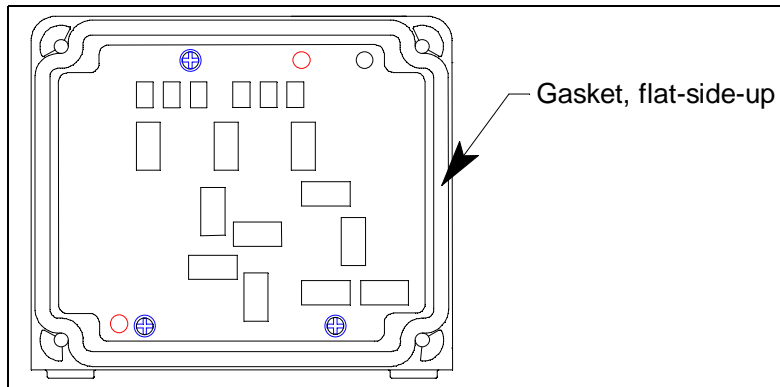

Figure 22: Reinstalling Battery Board Screws

13. Reinstall the rear case to the front case using the screws removed in Step 4.

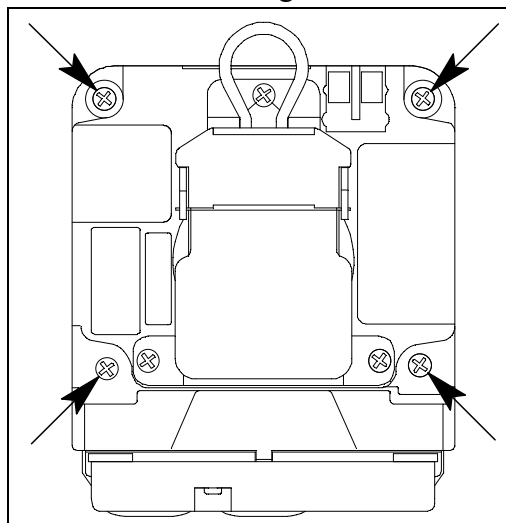

Figure 23: Removing Case Screws

14. Reinstall the rubber boot, if being used.
15. Turn on the GX-3R.
16. If the instruments goes into a clock failure, set the date/time as described on page 94.

Chapter 7: Storage and Disposal

Storage

- Store away from direct sunlight
- Store in a location with normal temperature and humidity
- Store in a location free of gases, solvents, and vapors
- Store away from dust and dirt
- Discharge the battery to 1 bar in the battery icon to help prolong battery life and prevent battery deterioration
- The GX-3R draws a small amount of power even while it is shut off. A GX-3R with a full battery can be stored for 3 years without losing power. A GX-3R with a battery in low battery alarm can be stored for about 3 months without losing power. If a GX-3R completely loses power during storage, the date/time must be reset as described on page 94.

Disposal

- Remove the batteries
- Dispose in accordance with local regulations

Chapter 8: General Parts List

Table 16: General Parts List

Part Number	Description
06-1248RK-03	Calibration kit tubing, 3 foot length
10-1083	Screw for belt clip
10-1086	Screw with flat and lock washers, for alligator clip
10-1087	Screw, for bottom cover and for battery pack
13-0112RK	Wrist strap
13-0124	Alligator clip with 3 installation screws
13-0125	Belt clip with 3 installation screws
20-0332	Rubber boot, black
20-0333	Leather case
20-0334	Heat-resistant case
21-1950	Screen protector
21-1962	Bottom cover
21-1963	Sensor retainer
33-0183	Filter gasket/hydrophobic dust filter assembly, 1 set (to replace hydrophobic dust filters that are separate from the filter gasket <u>and</u> to replace filter gasket/hydrophobic dust filter assemblies)
33-0183-10	Filter gasket/hydrophobic dust filter assembly, 10 sets (to replace hydrophobic dust filters that are separate from the filter gasket <u>and</u> to replace filter gasket/hydrophobic dust filter assemblies)
33-0553	Buzzer cover
33-7130	Charcoal filter/humidity filter disk (black and white), for dual CO/H ₂ S sensor, 5 pack
33-7131	H ₂ S scrubber disk (dark red), for combustible gas sensor, 5 pack
33-7132	Charcoal filter disk (black), for CO and H ₂ -compensated CO sensors, 5 pack
33-7133	Humidity filter (white), for H ₂ S sensor, 5 pack
47-1019	Charging cable for multi-unit charger, 2 feet
47-5084RK	USB/IrDA adapter module, no USB cable (for all premier portables)
47-5084RK-01	USB/IrDA adapter module, with USB cable (for all premier portables)

Table 16: General Parts List (Continued)

Part Number	Description
47-5085RK	USB A to USB mini cable, 6 feet, for 47-5084RK
47-5102	5 47-1019 charging cables with connector bar, no AC adapter
49-0133	Single-unit AC adapter, with 4 foot cable
49-0134	Multi-unit AC adapter, with 2 foot cables
49-2021	Single-unit DC adapter, with 4 foot cable
57-2098	Replacement Li-ion battery with board
65-7004	Dummy sensor
71-0477	Operator's Manual, GX-3R (this document)
71-0491	Operator's Manual, GX-3R Datalogging Program
81-0000RK-51	Calibration cylinder, 200 ppm H ₂ in air, 34 liter steel
81-0090RK-01	Calibration cylinder, 3-gas (CH ₄ /O ₂ /CO), 34 liter steel
81-0090RK-03	Calibration cylinder, 3-gas (CH ₄ /O ₂ /CO), 103 liter
81-0154RK-02	Calibration cylinder, 4-gas (CH ₄ /O ₂ / H ₂ S/CO), 58 liter
81-0154RK-04	Calibration cylinder, 4-gas (CH ₄ /O ₂ / H ₂ S/CO), 34 liter aluminum
81-1050RK-25	Regulator, fixed flow, 0.25 LPM, with gauge and knob, for 17 liter and 34 liter steel cylinders (cylinders with external threads)
81-1051RK-25	Regulator, fixed flow, 0.25 LPM, with gauge and knob, for 34 liter aluminum, 58 liter, and 103 liter cylinders (cylinders with internal threads)
81-1161	Aspirator assembly: Sample cup, aspirator bulb, 10 foot hose, and probe
81-1192	Calibration cup/sample cup for aspirator assembly
81-GX3RCO	Calibration kit: 103 liter 3-gas (CH ₄ /O ₂ /CO) cylinder, 0.25 LPM regulator, calibration tubing, and case
81-GX3RCO-LV	Calibration kit: 34 liter steel 3-gas (CH ₄ /O ₂ / CO) cylinder, 0.25 LPM regulator, calibration tubing, and case
81-GX3RHSCO	Calibration kit: 58 liter 4-gas (CH ₄ /O ₂ / H ₂ S/CO) cylinder, 0.25 LPM regulator, calibration tubing, and case
81-GX3RHSCO-LV	Calibration kit: 34 liter aluminum 4-gas (CH ₄ /O ₂ / H ₂ S/CO) cylinder, 0.25 LPM regulator, calibration tubing, and case
81-GX3RHSCO-116	Calibration kit: 116 liter aluminum 4-gas (CH ₄ /O ₂ / H ₂ S/CO), 0.25 LPM regulator, calibration tubing, and case

Table 16: General Parts List (Continued)

Part Number	Description
ESR-A13i-H2S	Hydrogen sulfide (H ₂ S) sensor
ESR-A13P-CO	Carbon monoxide (CO) sensor
ESR-A1CP-CO-H	Hydrogen-compensated carbon monoxide (CO) sensor
ESR-A1DP-COHS	Dual carbon monoxide (CO) and hydrogen sulfide (H ₂ S) sensor
ESR-X13P-OXY	Oxygen sensor
NCR-6309	Combustible gas sensor, catalytic

Appendix A: Maintenance Mode

Overview

This appendix describes the GX-3R in Maintenance Mode. The GX-3R is factory-set to suit most applications. Update settings in Maintenance Mode only if required for your specific application. Maintenance Mode items and their factory settings are listed in Table 17.

Table 17: Maintenance Mode Menu Items

Maintenance Mode Menu Item	Description
GAS CAL (page 121)	Perform an air adjust, perform a span adjustment, change the calibration values, set the cylinder group.
	AIR CAL Perform a fresh air adjustment.
	AUTO CAL Perform a span adjustment, set the calibration gas concentration, and set the cylinder for each gas.
	AUTO CAL CYL X Perform an automatic span adjustment on the gases selected for Cylinder X (A-E cylinders available).
	START Begin the warmup sequence and enter Measuring Mode.
	CAL-P Set the calibration concentration for each gas.
	CYL SEL Assign a cylinder (A-E) to each gas (all 4 gases set to Cylinder A is the default). For single cal operation, you would assign each gas its own cylinder.
	ESCAPE Return to the AUTO CAL menu item.
ESCAPE Return to the GAS CAL menu item.	
GAS TEST (page 122)	Apply gas to test sensor response and observe alarm indications without an alarm event being recorded.
SEN DATE (page 124)	View the replacement date for each sensor and the battery and/or set the replacement date for each sensor or the battery to the current date.

Table 17: Maintenance Mode Menu Items

Maintenance Mode Menu Item	Description	
BUMP (page 125)	Perform a bump test.	
	BUMP CYL X	Perform a bump test on the gases selected for Cylinder X (A-E cylinders available)
	START	Begin the warmup sequence and enter Measuring Mode.
	ESCAPE	Return to the BUMP menu item.
LATCHING (page 126)	<p>ON (factory setting): The GX-3R remains in alarm until the alarm condition passes <i>and</i> POWER MODE is pressed.</p> <p>OFF: The GX-3R automatically resets an alarm when the alarm condition passes.</p>	
DEM ZERO (page 126)	<p>ON (factory setting): You can manually perform a fresh air adjust in Measuring Mode by pressing AIR.</p> <p>OFF: You cannot manually perform a fresh air adjust in Measuring Mode by pressing AIR.</p>	
AUTOZERO (page 127)	<p>ON: The GX-3R asks if you want to perform a fresh air adjustment at the end of the startup sequence.</p> <p>OFF (factory setting): The GX-3R does not ask if you want to perform a fresh air adjustment at the end of the startup sequence.</p>	
ID DISP (page 127)	<p>ON: User ID and Station ID screens appear in startup sequence. IDs can be changed in Display Mode if DISP.SET in User Mode is also set to ON.</p> <p>OFF (factory setting): User ID and Station ID screens do not appear in startup sequence. IDs cannot be changed in Display Mode.</p>	
ZERO SUP (page 128)	<p>ON (factory setting): Not intended for field adjustment. The suppression values are:</p> <p>Combustible Gas: 2% LEL</p> <p>O₂: 0.5% volume</p> <p>H₂S: 0.3 ppm</p> <p>CO: 2 ppm</p>	
ZERO.FLWR (page 128)	<p>ON (factory setting): Not intended for field adjustment. Oxygen channel does not support zero follower functionality.</p>	
ZSUP.DISP (page 128)	<p>ON (factory setting): Zero suppression menu item appears in User Mode.</p> <p>OFF: Zero suppression menu item does not appear in User Mode.</p> <p>(Zero suppression menu item is always available in Maintenance Mode)</p>	
ZFLW.DISP (page 128)	<p>ON: Zero follower menu item appears in User Mode.</p> <p>OFF (factory setting): Zero follower menu item does not appear in User Mode.</p> <p>(Zero follower menu item is always available in Maintenance Mode)</p>	

Table 17: Maintenance Mode Menu Items

Maintenance Mode Menu Item	Description
DATE (page 129)	Set the current date and time.
PASSWORD (page 129)	ON (factory setting): Maintenance Mode is password-protected. Factory-set password is 8102 . OFF: Maintenance Mode is not password-protected.
ROM/SUM (page 130)	View the firmware information for the GX-3R's sensor board, main board, and gas list.
M.DEFAULT (page 131)	Set all parameters back to their RKI factory settings.
START (page 132)	Press and release POWER MODE to begin the warmup sequence and enter Measuring Mode.

Entering Maintenance Mode

WARNING: The GX-3R is not in operation as a gas detector while in Maintenance Mode.

1. Take the GX-3R to a non-hazardous location and turn it off if it is on.
2. Press and hold AIR, then press and hold POWER MODE. You will hear a beep after one second. Continue to hold the buttons down.
3. When you hear a second beep, release the buttons.
4. The screen that appears depends on the setting of Maintenance Mode's **PASSWORD** item.
If **PASSWORD** is set to **OFF**, continue with Step 8.
If **PASSWORD** is set to **ON** (factory setting), continue with Step 5.

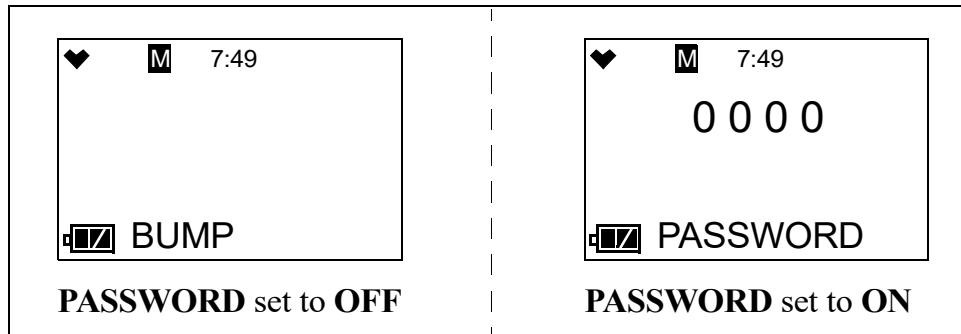

5. If **PASSWORD** is set to **ON** in Maintenance Mode, a password screen appears. The first digit flashes. The factory-set password is **8102** but it can be changed as desired.

6. Use AIR to select each password number then press POWER MODE to save it and move on to the next number. To go back a number, press and hold AIR and POWER MODE for a few seconds. To reverse the direction of change (ie. from increasing to decreasing or vice versa):
 - a. Press and hold AIR.
 - b. Immediately press POWER MODE and then release both buttons.
7. Continue to Step 6.
8. The **GAS CAL** menu item displays.

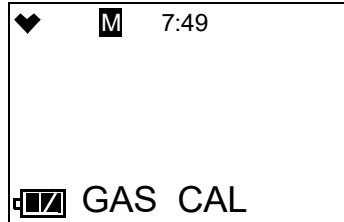

9. **M** at the top of the screen indicates that the GX-3R is in Maintenance Mode.
10. Use AIR to move through the Maintenance Mode menu items.

Tips for Using Maintenance Mode

- To scroll from one menu item to the next, press and release AIR. To reverse the scrolling direction:
 - a. Press and hold AIR.
 - b. Immediately press POWER/MODE and then release both buttons.
 - c. The scrolling direction returns to the original direction when you exit and reenter a menu.
- To skip an item when a question is asked, press and release AIR.
- To enter an item and to save any changes, press and release POWER MODE.
- To change a flashing parameter, press and release AIR. To reverse the direction of change (i.e. from increasing to decreasing or vice versa):
 - a. Press and hold AIR.
 - b. Immediately press POWER MODE and then release both buttons.
- To exit an entered menu item without saving a change, press and hold AIR and POWER MODE for a few seconds.

Performing a Calibration (GAS CAL)

See “Performing a Calibration (GAS CAL)” on page 67 for a description of the **GAS CAL** menu item.

Performing a Gas Test (GAS TEST)

The **GAS TEST** menu item allows you to apply gas to the instrument and see all alarm indications except for the buzzer indication. There is no buzzer indication in the **GAS TEST** menu even though the buzzer will sound in the event of a real gas alarm condition while in Measuring Mode.

Preparing for a Gas Test

To perform a gas test on the GX-3R, you will need:

- A calibration cylinder. The concentrations should be above the alarm condition you want to check. Standard alarm points are listed on page 11.
 - 0.25 LPM fixed flow regulator
 - Non-absorbent tubing
 - Calibration cup
1. Install the calibration cup onto the GX-3R. Use the label and imprinting to make sure that the calibration cup gets installed in the correct orientation relative to the GX-3R. Be sure the calibration cup is pushed on all the way.

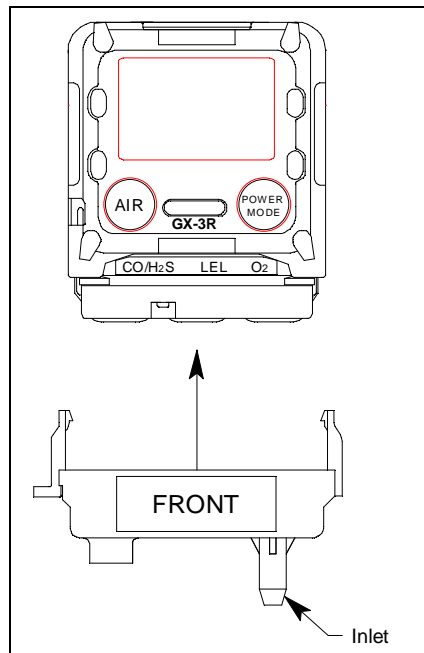
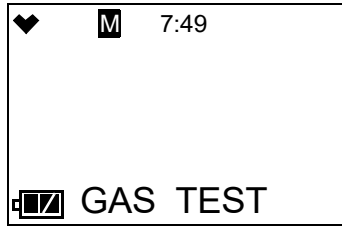

Figure 24: Calibration Cup Installation

2. Use the tubing to connect the regulator to the inlet of the calibration cup.

Performing a Gas Test

1. While in Maintenance Mode, press AIR to scroll to **GAS TEST**.



2. Press and release POWER MODE. The current gas readings display. The bottom of the LCD alternates between “GAS TEST” and “BUZZ OFF”.

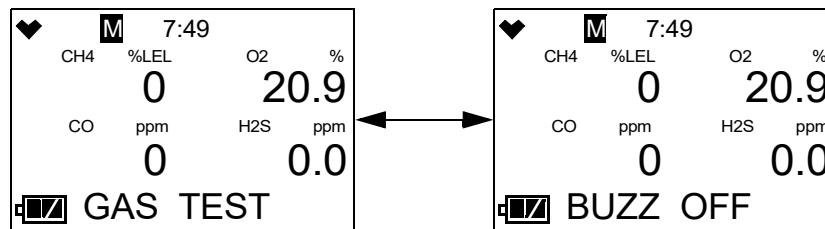

3. For toxic gas cylinders (like cylinders containing H₂S), it is important to vent the regulator while installing it onto the cylinder. Venting the regulator during installation helps prevent air from getting into the cylinder and degrading the gas. Open the regulator by turning the knob counterclockwise and install it onto the cylinder.
4. The instrument initiates alarm indications except for the buzzer. There is no buzzer indication in the **GAS TEST** menu even though the buzzer will sound in the event of a real gas alarm condition.
5. Turn the regulator knob clockwise to close the regulator.
6. Unscrew the regulator from the calibration cylinder.
7. Remove the calibration cup from the GX-3R.
8. Store the calibration kit in a safe and convenient place.
9. Press and release POWER MODE to return to the **GAS TEST** menu item in Maintenance Mode.
10. See “Entering Measuring Mode (START)” on page 132 to enter Measuring Mode.

Sensor/Battery Replacement Date (SEN DATE)

The **SEN DATE** menu item allows you to keep track of when the sensors and the battery were replaced.

1. While in Maintenance Mode, press AIR to scroll to **SEN DATE**.

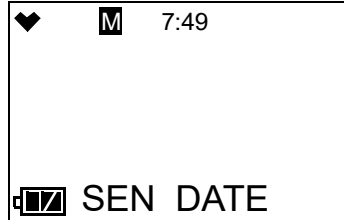

2. Press and release POWER MODE. The combustible gas sensor's replacement date displays.

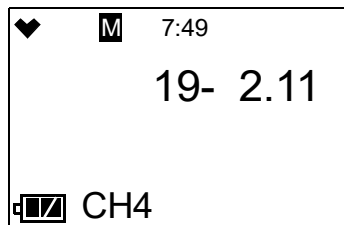

- Use AIR to scroll to the item whose replacement date you want to view or change.

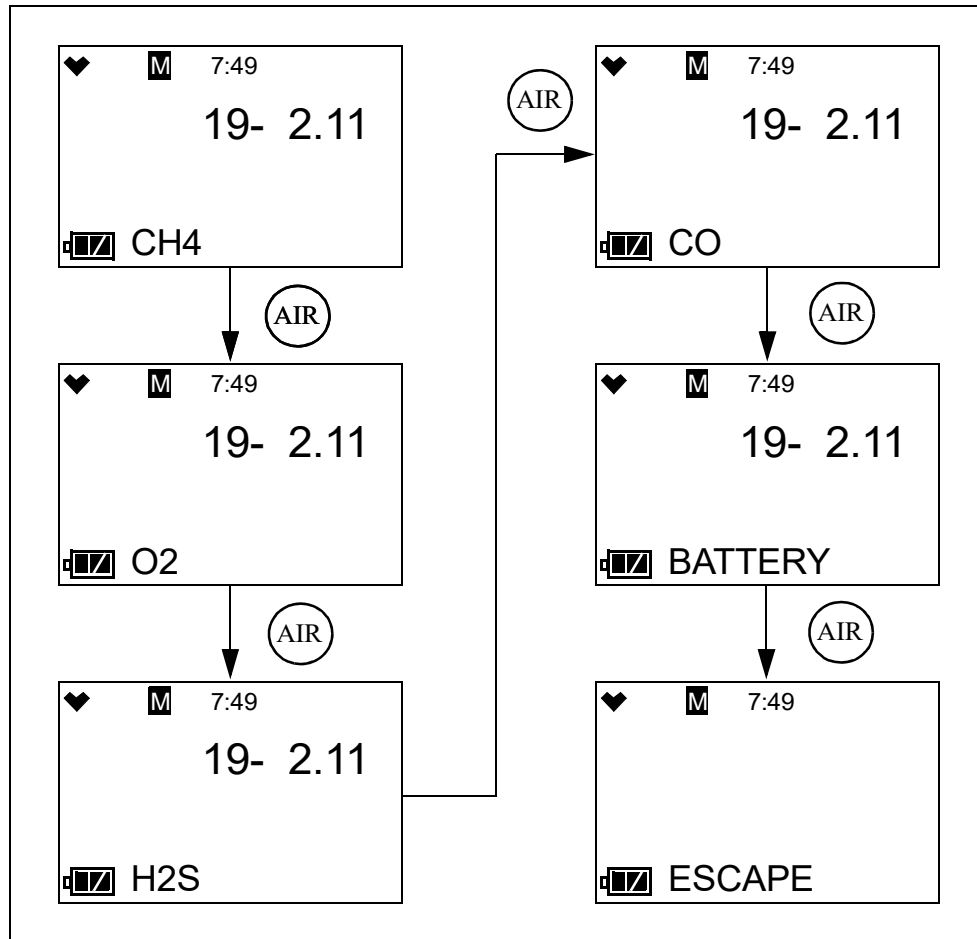

- To change the replacement date:
 - With the desired item displayed, press and release POWER MODE.
 - Press and release POWER MODE again to set the replacement date to the current date.
- Use the AIR button to scroll to the **ESCAPE** menu item.
- Press and release POWER MODE to return to the **SEN DATE** menu item in Maintenance Mode.
- See “Entering Measuring Mode (START)” on page 132 to enter Measuring Mode.

Performing a Bump Test (BUMP)

See “Performing a Bump Test (BUMP)” on page 60 for a description of the **BUMP** menu item.

Setting Alarms to Latching or Self-Resetting (LATCHING)

ON (factory setting): The GX-3R remains in alarm until the alarm condition passes *and* POWER MODE is pressed.

OFF: The GX-3R automatically resets an alarm when the alarm condition passes.

1. While in Maintenance Mode, press AIR to scroll to **LATCHING**.

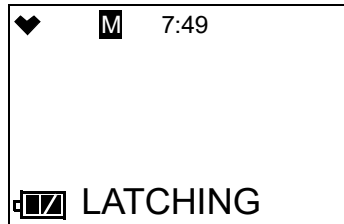

2. Press and release POWER MODE. The current setting flashes.
3. Use AIR to display the desired setting.
4. Press and release POWER MODE to save the setting and return to the **LATCHING** menu item.
5. See “Entering Measuring Mode (START)” on page 132 to enter Measuring Mode.

Turning the Demand Zero Function On/Off (DEM ZERO)

ON (factory setting): You can manually perform a fresh air adjust in Measuring Mode by pressing AIR.

OFF: You cannot manually perform a fresh air adjust in Measuring Mode.

1. While in Maintenance Mode, press AIR to scroll to **DEM ZERO**.

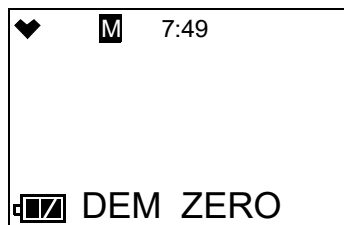

2. Press and release POWER MODE. The current setting flashes.
3. Use AIR to display the desired setting.
4. Press and release POWER MODE to save the setting and return to the **DEM ZERO** menu item.
5. See “Entering Measuring Mode (START)” on page 132 to enter Measuring Mode.

Turning the Auto Zero Function On/Off (AUTOZERO)

ON: The GX-3R asks if you want to perform a fresh air adjustment at the end of the startup sequence.

OFF (factory setting): The GX-3R does not ask if you want to perform a fresh air adjustment at the end of the startup sequence.

1. While in Maintenance Mode, press AIR to scroll to **AUTOZERO**.

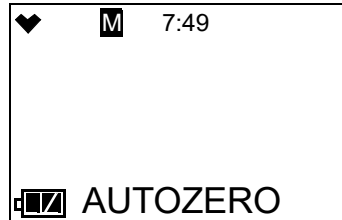

2. Press and release POWER MODE. The current setting flashes.
3. Use AIR to display the desired setting.
4. Press and release POWER MODE to save the setting and return to the **AUTOZERO** menu item.
5. See “Entering Measuring Mode (START)” on page 132 to enter Measuring Mode.

Turning the ID Display Function On/Off (ID DISP)

ON: The User ID and Station ID screens appear in startup sequence. If **DISP.SET** in User Mode is also set to **ON**, then the IDs can be changed in Display Mode.

OFF (factory setting): The User ID and Station ID screens do not appear in startup sequence and the IDs cannot be changed in Display Mode.

1. While in Maintenance Mode, press AIR to scroll to **ID DISP**.

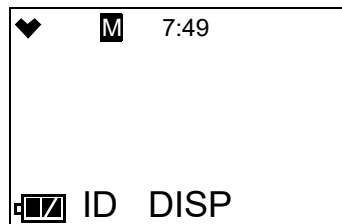

2. Press and release POWER MODE. The current setting flashes.
3. Use AIR to display the desired setting.
4. Press and release POWER MODE to save the setting and return to the **ID DISP** menu item.
5. See “Entering Measuring Mode (START)” on page 132 to enter Measuring Mode.

Turning the Zero Suppression On/Off (ZERO SUP)

The **ZERO SUP** setting is not intended for field adjustment. The default setting for each sensor is **ON**.

Sensor	Zero Suppression Value
Combustible Gas	2% LEL
O ₂	0.5% volume
H ₂ S	0.3 ppm
CO	2 ppm

Turning the Zero Follower On/Off (ZERO.FLWR)

The **ZERO.FLWR** setting is not intended for field adjustment. The default setting is **ON**. The oxygen channel does not support zero follower functionality.

User Mode Zero Suppression (ZSUP.DISP)

ON (factory setting): Zero suppression menu item appears in User Mode.

OFF: Zero suppression menu item does not appear in User Mode. The zero suppression menu item is always available in Maintenance Mode.

User Mode Zero Follower (ZFLW.DISP)

ON: Zero follower menu item appears in User Mode.

OFF (factory setting): Zero follower menu item does not appear in User Mode. The zero follower menu item is always available in Maintenance Mode.

It is not normally necessary to have the zero follower menu item appear in User Mode. Contact RKI Instruments before turning this setting on.

Setting the Date/Time (DATE)

1. From the main menu, place the cursor next to **DATE**.

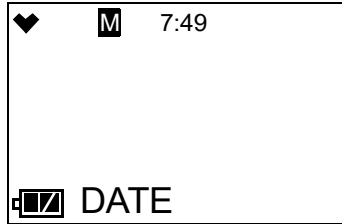

2. Press and release POWER MODE. The date and time display with the year flashing.

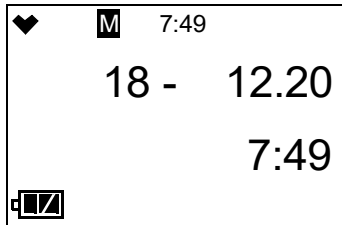

3. Use AIR to display the desired year.
4. Press and release POWER MODE to save the setting. The month setting flashes.
5. Repeat Step 3 and Step 4 to enter the month, day, hours, and minutes settings. The date and time are saved and the instrument returns to the **DATE** menu item.
6. See “Entering Measuring Mode (START)” on page 132 to enter Measuring Mode.

Turning the Password On/Off (PASSWORD)

ON (factory setting): The GX-3R prompts you for a password when you enter Maintenance Mode. The factory-set password is **8102** but it can be changed as desired.

OFF: No password is required to enter Maintenance Mode.

1. While in Maintenance Mode, press AIR to scroll to **PASSWORD**.

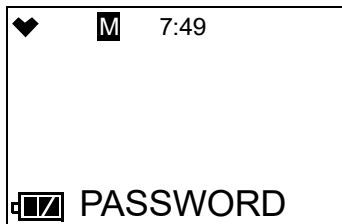

2. Press and release POWER MODE. The current setting flashes.
3. Use AIR to display the desired setting.

- If you selected **OFF**, press and release **POWER MODE** to save the setting and return to the **PASSWORD** item in Maintenance Mode.
If you selected **ON**, continue with Step 5.
- Press and release **POWER MODE**. The Set Password Screen appears. The current password appears and the first digit flashes.

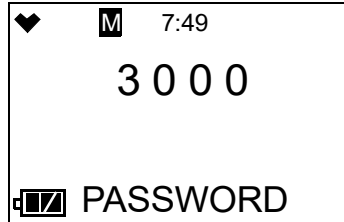

- Use **AIR** to display a number from 0 to 9.
- Press and release **POWER MODE** to enter the selection and advance to the next number. To go back a number, press and hold **AIR** and **POWER MODE** for a few seconds.
- Repeat Step 6 and Step 7 to select the remaining numbers. When you press and release **POWER MODE** to enter the last number, the password is saved and the instrument returns to the **PASSWORD** item in Maintenance Mode.
- See “Entering Measuring Mode (START)” on page 132 to enter Measuring Mode.

Viewing the ROM/SUM (ROM/SUM)

The **ROM/SUM** screen shows the instrument’s firmware version and the firmware checksum.

- While in Maintenance Mode, press **AIR** to scroll to **ROM/SUM**.

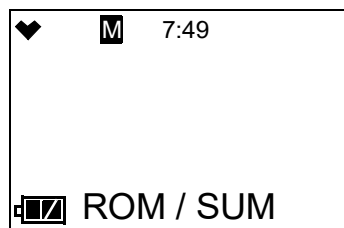

2. Press and release POWER MODE. The screen cycles through the main board's ROM/SUM, the sensor board's ROM/SUM, and the gas list's ROM/SUM. The ROM is the top value and the SUM is the bottom value.

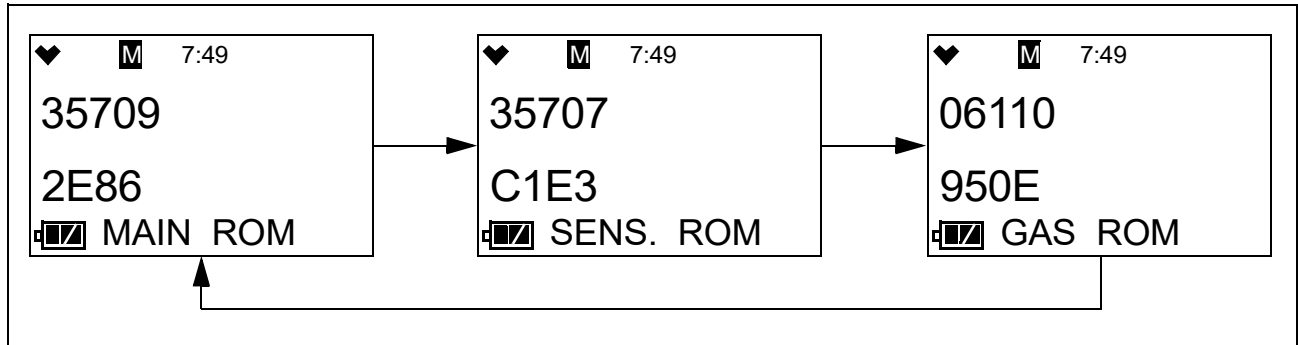

3. Press and release POWER MODE to return to the **ROM/SUM** menu item in Maintenance Mode.
4. See “Entering Measuring Mode (START)” on page 132 to enter Measuring Mode.

Performing a Default (M.DEFAULT)

Performing a default operation in Maintenance Mode returns all parameters to their RKI factory settings.

1. While in Maintenance Mode, press AIR to scroll to **M.DEFAULT**.

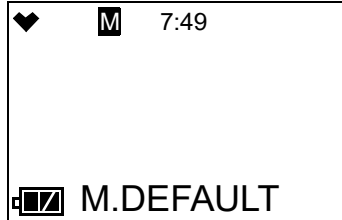

2. Press and release POWER MODE to continue. Press and release AIR to return to the **M.DEFAULT** menu item in Maintenance Mode.

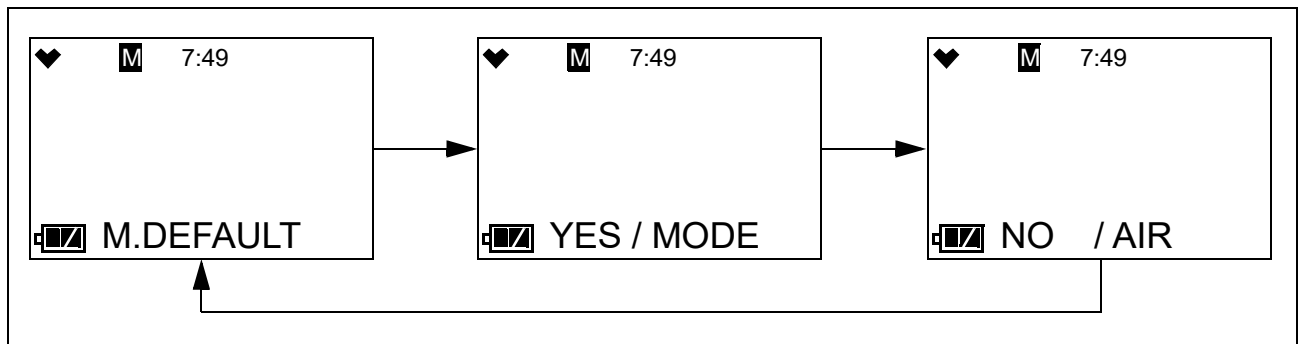

3. Press and release POWER MODE to perform a default operation. The instrument asks if you are sure you want to perform a default operation.

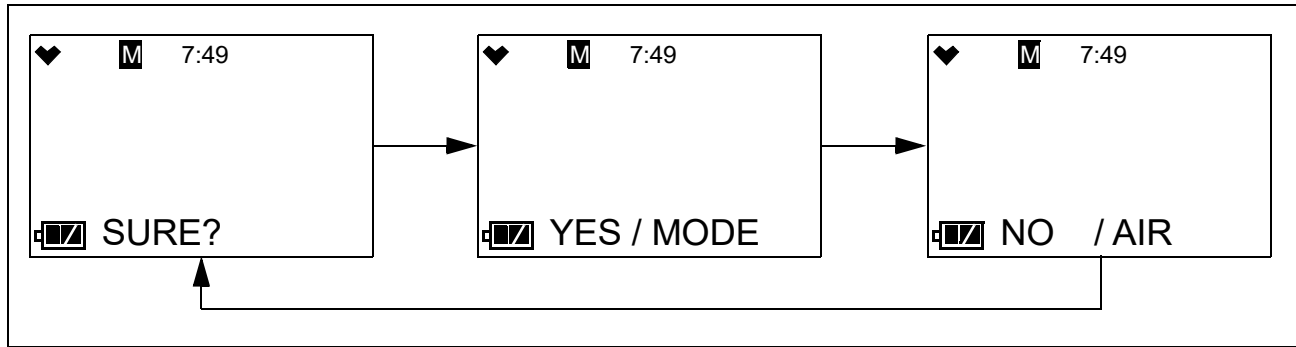

4. Press and release POWER MODE to perform a default operation. Press and release AIR to return to **M.DEFAULT** menu item in Maintenance Mode.
5. The instrument beeps twice and returns to the **M.DEFAULT** menu item in Maintenance Mode.
6. See “Entering Measuring Mode (START)” on page 132 to enter Measuring Mode.

Entering Measuring Mode (START)

1. While in Maintenance Mode, press AIR to scroll to **START**.



2. Press and release POWER MODE. The instrument begins its warmup sequence.

Appendix B: Gas Select Mode

Overview

This appendix describes the GX-3R in Gas Select Mode. The GX-3R is factory-set to suit most applications. Update settings in Gas Select Mode only if required for your specific application. A description of the Gas Select Mode items is shown in Table 18.

Table 18: Gas Select Mode Menu Items

Menu Item (Page # of Description)	Description
GAS COMB (page 135)	Turn channels on or off and change target gas for each channel.
SAVE-AP (page 137)	Set the current alarm points as the default alarm points.
MAX SPAN (page 138)	ON : Maximum span screen appears after a successful calibration. OFF (factory setting) : No maximum span screen appears.
STEALTH (page 138)	STEALTH ON : No backlight, LED, or buzzer operation. STEALTH OFF (factory setting) : Backlight, LED, and buzzer operate normally.
	This setting has no effect unless STEALTH is set to ON. VIB ON : Vibrator activates for alarm conditions. VIB OFF (factory setting) : Vibrator does not activate in any situation.
CHG LEL (page 139)	STANDARD (factory setting) : Apply standard settings for lower explosive limit's ppm level. IEC : Apply IEC standards for the lower explosive limit's ppm level. ISO : Apply ISO standards for the lower explosive limit's ppm level.
START (page 141)	Enter Measuring Mode

Entering Gas Select Mode

WARNING: *The GX-3R is not in operation as a gas detector while in Gas Select Mode.*

1. Take the GX-3R to a non-hazardous location and turn it off if it is on.
2. Press and hold AIR, then press and hold POWER MODE. You will hear a beep after one second. Continue to hold the buttons down.
3. You will hear a second beep. Continue to hold the buttons down.
4. When you hear a third beep, release the buttons.

5. A password screen appears. The first digit flashes. The password is **2014**.

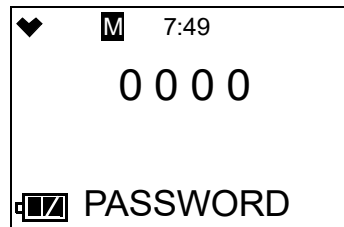

6. Use AIR to select each password number then press POWER MODE to save it and move on to the next number. To go back a number, press and hold AIR and POWER MODE for a few seconds. To reverse the direction of change (ie. from increasing to decreasing or vice versa):
- Press and hold AIR.
 - Immediately press POWER MODE and then release both buttons.
7. The **GAS COMB** menu item displays.

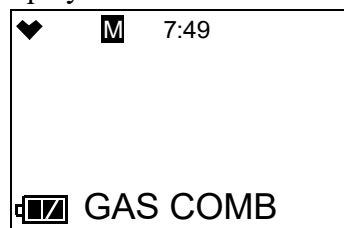

8. **M** at the top of the screen indicates that the GX-3R is in Gas Select Mode.
9. Use AIR to move through the Gas Select Mode menu items.

Tips for Using Gas Select Mode

To scroll from one menu item to the next, press and release AIR. To reverse the scrolling direction:

- Press and hold AIR.
- Immediately press POWER/MODE and then release both buttons.
- The scrolling direction returns to the original direction when you exit and reenter a menu.

To skip an item when a question is asked, press and release AIR.

To enter an item and to save any changes, press and release POWER MODE.

- To change a flashing parameter, press and release AIR. To reverse the direction of change (i.e. from increasing to decreasing or vice versa):
 - Press and hold AIR.
 - Immediately press POWER MODE and then release both buttons.
- To exit an entered menu item without saving a change, press and hold AIR and POWER MODE for a few seconds.

Changing the Gas Combination (GAS COMB)

The **GAS COMB** menu item allows you to turn channels on and off and change each channel's target gas.

If you want the combustible gas channel to be calibrated to a specific target gas, select that target gas here and then calibrate to it in User Mode (see page 67).

1. While in Gas Select Mode, press **AIR** to scroll to **GAS COMB**.

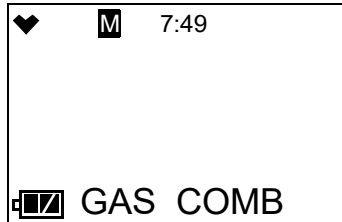

2. Press and release **POWER MODE**. The first channel displays.

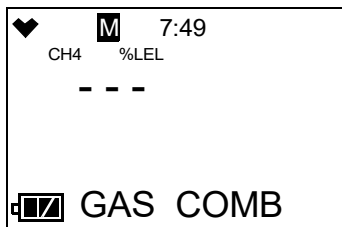

3. Press **AIR** to scroll through to the instrument channel whose target gas you want to change.

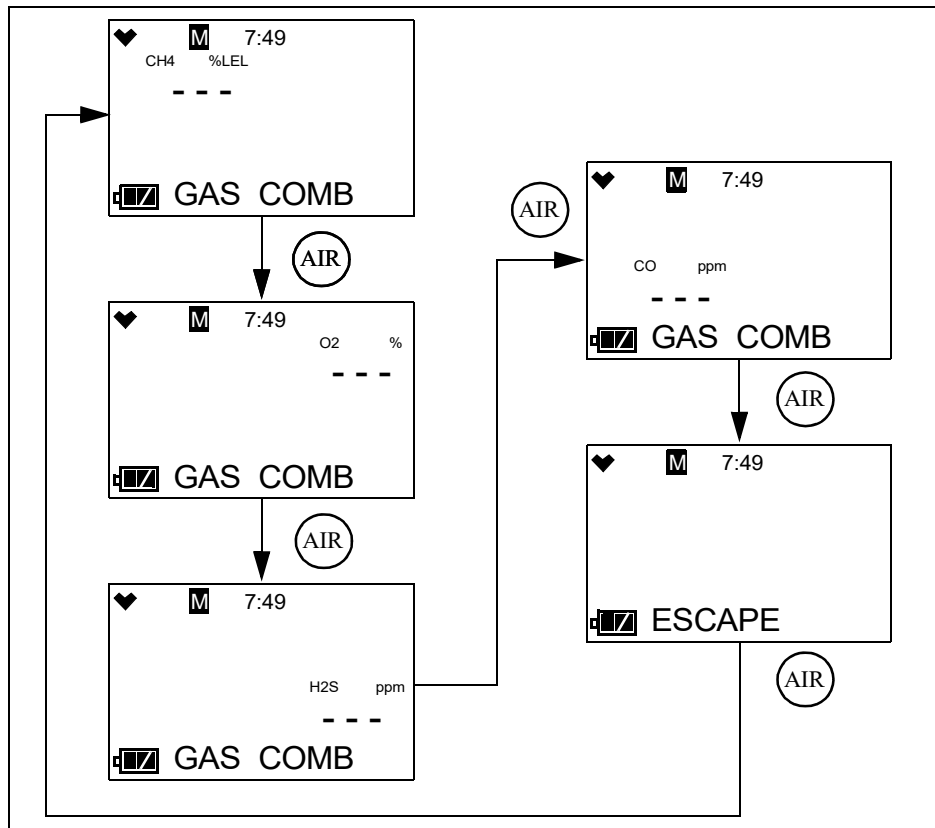

4. Press and release POWER MODE.
5. The target gas for the selected channel flashes. In the example below, the combustible gas channel is selected.

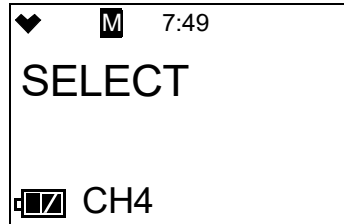

6. Use AIR to change the target gas or turn the channel off.

Table 19: Target Gas Options for Each Channel

Channel	Target Gas Options
Combustible Gas	<ul style="list-style-type: none"> • CH4 (methane) • i-C4H10 (isobutane) • H2 (hydrogen) • CH3OH (methanol) • C2H2 (acetylene) • C2H4 (ethylene) • C2H6 (ethane) • C2H5OH (ethanol) • C3H6 (propylene) • C3H6O (acetone) • C3H8 (propane) • C4H6 (butyne) • C5H10 (cyclopentane) • C6H6 (benzene) • n-C6H14 (hexane) • C7H8 (toluene) • n-C7H16 (heptane) • C8H10 (xylene) • n-C9H20 (nonane) • EtAc (ethyl acetate) • IPA (isopropyl alcohol) • MEK (methyl ethyl ketone) • MMA (methyl methacrylate) • DME (dimethyl ether) • MIBK (methyl isobutyl ketone) • THF (tetrahydrofuran) • n-C5H12 (n-pentane) • CH4_VOL (methane %volume)* • ----- (off)
O2	<ul style="list-style-type: none"> • O2 (oxygen) • ----- (off)
H2S	<ul style="list-style-type: none"> • H2S (hydrogen sulfide for dual CO/H₂S sensor) • H2S SING (hydrogen sulfide for single-gas H₂S sensor) • H2_CO-H2 (hydrogen compensated CO) • ----- (off)
CO	<ul style="list-style-type: none"> • CO (carbon monoxide for dual CO/H₂S sensor or single-gas CO sensor) • CO_CO-H2 (hydrogen compensated CO) • ----- (off)
<p>* If CH4_VOL is selected, the CHG LEL item in Gas Select Mode has no effect on operation.</p>	

7. Press and release POWER MODE to save the setting.
8. The instrument returns to the channel selection screen.
9. Repeat Step 3 - Step 8 to change the target gas for other channels.
10. Use AIR to scroll to **ESCAPE** and press and release POWER MODE.
11. The instrument returns to the **GAS COMB** menu item.
12. See “Exiting Gas Select Mode (START)” on page 141 to enter Measuring Mode.

Saving the Alarm Points (SAVE-AP)

Performing a **SAVE-AP** operation saves the current alarm setpoints.

Performing a **DEF ALMP** operation in the **ALARM-PT** User Mode menu item sets the instrument’s alarm points to those saved during the **SAVE-AP** operation (if performed).

Performing a **SAVE-AP** operation has no effect on an **M.DEFAULT** in Maintenance Mode. An **M.DEFAULT** operation returns all instrument settings to the RKI default regardless of if a **SAVE-AP** operation was performed.

1. While in Gas Select Mode, press AIR to scroll to **SAVE-AP**.

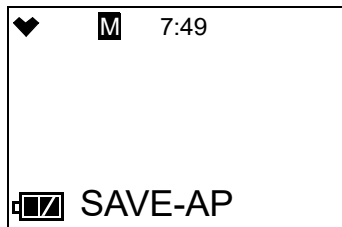

2. Press and release POWER MODE. The display cycles through the following screens.

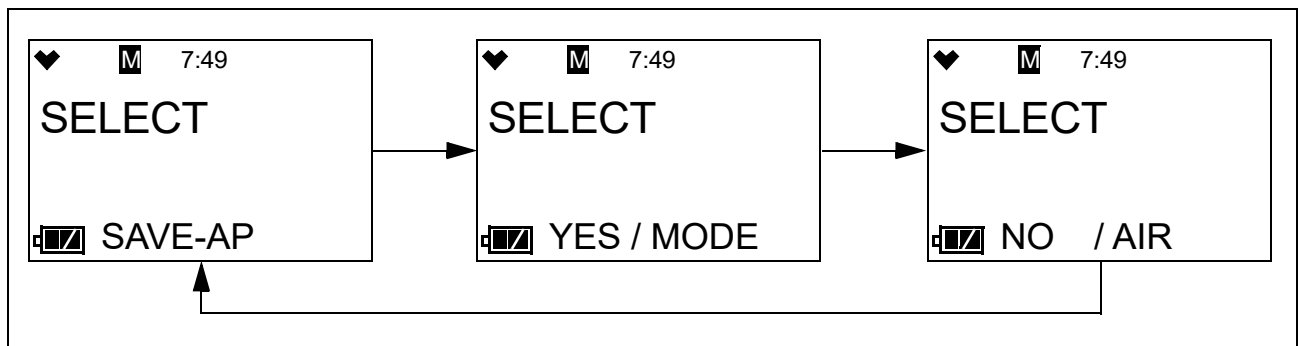

3. Press and release POWER MODE to save the current alarm point settings as the default.
4. The instrument returns to the **SAVE-AP** menu item.
5. See “Exiting Gas Select Mode (START)” on page 141 to enter Measuring Mode.

Turning Calibration Max Span On/Off (MAX SPAN)

ON: After a passed calibration, the GX-3R displays the maximum possible adjustment it could have made to the response reading. So if the combustible gas channel was calibrated with 50% LEL gas and the maximum indicated span is 95% LEL, this means that there was enough adjustment left on that channel to set the reading to 95% LEL when the detector was exposed to 50% LEL gas. If the maximum span value is close to the calibration gas value, for example if it is 53% LEL when exposed to 50% LEL gas, the sensor should be replaced soon. The upper limit on the maximum adjustment indicated for all channels except for oxygen is either twice the calibration value or full scale, whichever is lower. The upper limit on the maximum adjustment indicated for the oxygen channel is 25.0% volume.

OFF (factory setting): There is no maximum span indication at the end of a calibration.

1. While in Gas Select Mode, press AIR to scroll to **MAX SPAN**.

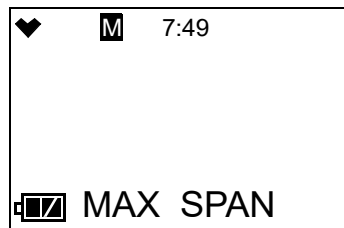

2. Press and release POWER MODE. The current setting flashes.
3. Use AIR to display the desired setting.
4. Press and release POWER MODE to save the setting and return to the **MAX SPAN** menu item.
5. See “Exiting Gas Select Mode (START)” on page 141 to enter Measuring Mode.

Stealth and Vibrator Settings (STEALTH)

STEALTH

ON:

- The instrument’s backlight does not come on, regardless of the **BL TIME** setting.
- The instrument’s LEDs do not come on for any reason, even alarm conditions.
- The instrument’s buzzer does not sound for any reason, even alarm conditions.
- An “S” appears at the top of the LCD.

OFF (factory setting): The instrument’s backlight and LEDs operate normally.

VIB

The **VIB** setting only affects instrument operation if **STEALTH** is set to **ON**.

ON: The vibrator activates for alarm conditions. It can be useful to have this feature turned on if you have also turned **STEALTH** on.

OFF (factory setting): The vibrator does not activate for any reason.

1. While in Gas Select Mode, press AIR to scroll to **STEALTH**.

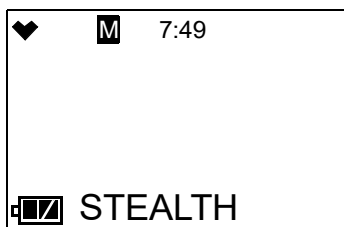

2. Press and release POWER MODE. The current **STEALTH** setting flashes.
3. Use AIR to display the desired setting.
4. Press and release POWER MODE. The current **VIB** setting flashes.
5. Use AIR to display the desired setting.
6. Press and release POWER MODE to save the setting and return to the **STEALTH** menu item.
7. See “Exiting Gas Select Mode (START)” on page 141 to enter Measuring Mode.

LEL Definition (CHG LEL)

NOTE: If **CH4_VOL** is selected for the combustible gas sensor in the **GAS COMB** menu item, the **CHG LEL** setting has no effect on operation.

The **CHG LEL** menu item defines what standard the instrument follows in determining the LEL (lower explosive limit) for the combustible channel’s target gas.

STANDARD: Apply the standard settings for the lower explosive limit’s ppm level.

IEC: Apply the IEC settings (per IEC 60079-20-1 2010[ed1.0]) for the lower explosive limit’s ppm level.

ISO: Apply the ISO settings (per ISO 10156 2017) for the lower explosive limit’s ppm level.

Gas	Standard (ppm)	IEC (ppm)	ISO (ppm)
Methane (CH ₄)	50,000	44,000	44,000
Isobutane (i-C ₄ H ₁₀)	18,000	13,000	15,000
Hydrogen (H ₂)	40,000	40,000	40,000
Methanol (CH ₃ OH)	55,000	60,000	60,000

Gas	Standard (ppm)	IEC (ppm)	ISO (ppm)
Acetylene (C ₂ H ₂)	15,000	23,000	23,000
Ethylene (C ₂ H ₄)	27,000	23,000	24,000
Ethane (C ₂ H ₆)	30,000	24,000	24,000
Ethanol (C ₂ H ₅ OH)	33,000	31,000	31,000
Propylene (C ₃ H ₆)	20,000	20,000	18,000
Acetone (C ₃ H ₆ O)	21,500	25,000	25,000
Propane (C ₃ H ₈)	20,000	17,000	17,000
Butadiene (C ₄ H ₆)	11,000	14,000	14,000
Cyclopentane (C ₅ H ₁₀)	14,000	14,000	14,000*
N-pentane (n-C ₅ H ₁₂)	15,000	11,000	11,000
Benzene (C ₆ H ₆)	12,000	12,000	12,000
N-hexane (n-C ₆ H ₁₄)	12,000	10,000	10,000
Toluene (C ₇ H ₈)	12,000	10,000	10,000
N-heptane (n-C ₇ H ₁₆)	11,000	8,500	8,000
Xylene (C ₈ H ₁₀)	10,000	10,000	10,000*
N-nonane (n-C ₉ H ₂₀)	7,000	7,000	7,000
Ethyl acetate (EtAc)	21,000	20,000	20,000
Isopropyl alcohol (IPA)	20,000	20,000	20,000*
Methyl ethyl ketone (MEK)	18,000	15,000	15,000
Methyl methacrylate (MMA)	17,000	17,000	17,000*
Dimethyl ether (DME)	30,000	27,000	27,000
Methyl isobutyl ketone (MIBK)	12,000	12,000	12,000*
Tetrahydrofuran (THK)	20,000	15,000	15,000*
* Values are actually IEC because no ISO definition exists for these gases.			

1. While in Gas Select Mode, press AIR to scroll to **CHG LEL**.

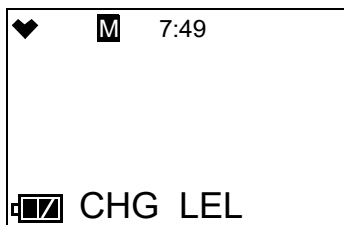

2. Press and release POWER MODE. The current setting flashes.
3. Use AIR to display the desired setting.
4. Press and release POWER MODE to save the setting and return to the **CHG LEL** menu item will be displayed.
5. See “Exiting Gas Select Mode (START)” on page 141 to enter Measuring Mode.

Exiting Gas Select Mode (START)

1. While in Gas Select Mode, press AIR to scroll to **START**.

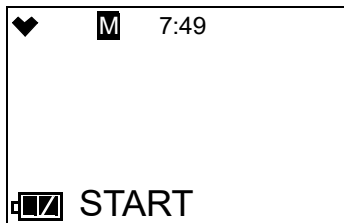

2. Press and release POWER MODE. The instrument begins its warm-up sequence.

Appendix C: Interference Information

All interference response values shown in this appendix are approximate. Response may vary between sensors.

ESR-A13i-H2S, H₂S Detection

Table 20: Interference Chart for ESR-A13i-H2S, H₂S Detection

Gas	Chemical Formula	Concentration	Indication Value
Acetone	C ₃ H ₆ O	0.54 vol%	0.0 ppm
Acetylene	C ₂ H ₂	100 ppm	0.0 ppm
Ammonia	NH ₃	38.6 ppm	0.0 ppm
Benzene	C ₆ H ₆	0.30 vol%	0.0 ppm
Carbon Dioxide	CO ₂	20.0 vol%	0.0 ppm
Carbon Monoxide	CO	100.0 ppm	0.2 ppm
Chlorine	CL ₂	2.0 ppm	0.0 ppm
Cyclopentane	C ₅ H ₁₀	0.35 vol%	0.0 ppm
Ethane	C ₂ H ₆	0.75 vol%	0.0 ppm ^{*1}
Ethanol	C ₂ H ₅ OH	0.83 vol%	-0.5 ppm ^{*1}
Ethyl Acetate	C ₄ H ₈ O ₂	0.53 vol%	-0.1 ppm ^{*1}
Fluorine	F ₂	1.6 ppm	0.0 ppm
Hydrogen	H ₂	500 ppm	0.2 ppm
Hydrogen Bromide	HBr	9.0 ppm	0.0 ppm
Hydrogen Chloride	HCl	3.2 ppm	0.0 ppm
Isobutane	i-C ₄ H ₁₀	0.45 vol%	0.0 ppm
Isobuten	C ₄ H ₈	1000 ppm	0.1 ppm
Isopropyl Alcohol	C ₃ H ₈ O	2.0 vol%	-0.5 ppm
Methane	CH ₄	1.26 vol%	0.0 ppm
Methanol	CH ₃ OH	1.38 vol%	-0.6 ppm ^{*1}
Methyl Ethyl Ketone	C ₄ H ₈ O	0.45 vol%	0.0 ppm

Table 20: Interference Chart for ESR-A13i-H2S, H₂S Detection

Gas	Chemical Formula	Concentration	Indication Value
Methyl Isobutyl Ketone	C ₆ H ₁₂ O	0.30 vol%	0.0 ppm
Methyl Methacrylate	C ₅ H ₈ O ₂	0.43 vol%	0.1 ppm ^{*1}
n-Hexane	n-C ₆ H ₁₄	0.30 vol%	0.0 ppm
Nitrogen Dioxide	NO ₂	5.0 ppm	-0.4 ppm
Nitrogen Monoxide	NO	99.2 ppm	2.6 ppm
Nonane	n-C ₉ H ₂₀	0.18 vol%	0.0 ppm
Ozone	O ₃	0.48 ppm	0.0 ppm
Phosphine	PH ₃	2.51 ppm	1.0 ppm
Propane	C ₃ H ₈	0.49 vol%	0.0 ppm
Propylene	C ₃ H ₆	0.5 vol%	-0.2 ppm
Sulfur Dioxide	SO ₂	25.0 ppm	0.0 ppm
Tetrahydrofuran	C ₄ H ₈ O	0.50 vol%	-0.4 ppm
Toluene	C ₇ H ₈	1.0 vol%	0.0 ppm
Xylene	C ₈ H ₁₀	0.25 vol%	0.0 pm
^{*1} The indicated value may fluctuate when exposed to this gas.			

ESR-A13P-CO, CO Detection

Table 21: Interference Chart for ESR-A13P-CO, CO Detection

Gas	Chemical Formula	Concentration	Indication Value
Acetone	$(\text{CH}_3)_2\text{CO}$	5380 ppm	0 ppm
Acetylene	C_2H_2	99.6 ppm	50 ppm
Ammonia	NH_3	255 ppm	1 ppm
Arsine	AsH_3	1.1 ppm	4 ppm
Benzene	C_6H_6	0.3 vol%	-1 ppm
Carbon Dioxide	CO_2	100 vol%	8 ppm
Chlorine	Cl_2	0.8 ppm	0 ppm
Cyclopentane	C_5H_{10}	0.35 vol%	0 ppm
Diborane	B_2H_6	5.25 ppm	2 ppm
Ethane	C_2H_6	0.75 vol%	-1 ppm
Ethanol	$\text{CH}_3\text{CH}_2\text{OH}$	0.825 vol%	2 ppm ^{*1}
Ethyl Acetate	$\text{CH}_3\text{COOCH}_2\text{CH}_3$	0.525 vol%	-1 ppm
Fluorine	F_2	1.6 ppm	-1 ppm
Germane	GeH_4	10.2 ppm	3 ppm
Hydrogen	H_2	100 ppm	11 ppm
Hydrogen Chloride	HCl	11.7 ppm	-1 ppm
Hydrogen Cyanide	HCN	1.8 ppm	-1 ppm
Hydrogen Selenide	H_2Se	1 ppm	1 ppm
Hydrogen Sulfide	H_2S	30 ppm	0 ppm
Isobutane	C_4H_{10}	0.45 vol%	-1 ppm
Isobuten	$(\text{CH}_3)_2\text{C}=\text{CH}_2$	1000 ppm	2 ppm
Isopropyl Alcohol	$(\text{CH}_3)_2\text{CHOH}$	0.5 vol%	-1 ppm
Methane	CH_4	1.25 vol%	0 ppm
Methanol	CH_3OH	1000 ppm	3 ppm
Methyl Ethyl Ketone	$\text{C}_4\text{H}_8\text{O}$	0.45 vol%	-1 ppm

Table 21: Interference Chart for ESR-A13P-CO, CO Detection

Gas	Chemical Formula	Concentration	Indication Value
Methyl Isobutyl Ketone	C ₆ H ₁₂ O	3000 ppm	-1 ppm
Methyl Methacrylate	C ₅ H ₈ O ₂	0.425 vol%	0 ppm
n-Heptane	CH ₃ (CH ₂) ₅ CH ₃	0.275 vol%	-1 ppm
n-Hexane	CH ₃ (CH ₂) ₄ CH ₃	0.3 vol%	0 ppm
Nitrogen Dioxide	NO ₂	50.5 ppm	1 ppm
Nitrogen Monoxide	NO	99.2 ppm	53 ppm
Nonane	CH ₃ (CH ₂) ₇ CH ₃	0.175 vol%	0 ppm
Ozone	O ₃	1.8 ppm	0 ppm
Phosphine	PH ₃	2.5 ppm	3 ppm
Propane	C ₃ H ₈	0.5 vol%	0 ppm
Propylene	C ₃ H ₆	5000 ppm	16 ppm
Silane	SiH ₄	29.9 ppm	27 ppm
Sulfur Dioxide	SO ₂	30 ppm	0 ppm
Tetrahydrofuran	C ₄ H ₈ O	0.5 vol%	0 ppm
Toluene	C ₆ H ₅ CH ₃	3000 ppm	0 ppm
Xylene	C ₆ H ₄ (CH ₃) ₂	2500 ppm	0 ppm
* ¹ The indicated value may fluctuate when exposed to this gas.			

ESR-A1CP-COH, H₂-Compensated CO Detection

Table 22: Interference Chart for ESR-A1CP-COH, H₂-Compensated CO Detection

Gas	Chemical Formula	Concentration	Indication Value
Acetone	C ₃ H ₆ O	0.54 vol%	1 ppm
Acetylene	C ₂ H ₂	100 ppm	109 ppm
Ammonia	NH ₃	38.6 ppm	0 ppm
Benzene	C ₆ H ₆	0.30 vol%	0 ppm
Carbon Dioxide	CO ₂	20.0 vol%	0 ppm
Chlorine	Cl ₂	2.0 ppm	-1 ppm
Cyclopentane	C ₅ H ₁₀	0.35 vol%	1 ppm
Ethane	C ₂ H ₆	0.75 vol%	0 ppm
Ethanol	C ₂ H ₅ OH	0.83 vol%	4 ppm ^{*1}
Ethyl Acetate	C ₄ H ₈ O ₂	0.53 vol%	1 ppm
Fluorine	F ₂	1.6 ppm	-1 ppm
Hydrogen	H ₂	500 ppm	7 ppm
Hydrogen Bromide	HBr	9.0 ppm	0 ppm
Hydrogen Chloride	HCl	15.8 ppm	0 ppm
Hydrogen Sulfide	H ₂ S	24.2 ppm	0 ppm
Isobutane	i-C ₄ H ₁₀	0.45 vol%	0 ppm
Isobuten	C ₄ H ₈ O	1000 ppm	3 ppm
Isopropyl Alcohol	C ₃ H ₈ O	0.50 vol%	0 ppm
Nitrogen Monoxide	NO	99.2 ppm	53 ppm
Nitrogen Dioxide	NO ₂	50.5 ppm	0 ppm
Methane	CH ₄	1.26 vol%	1 ppm
Methanol	CH ₃ OH	1.38 vol%	131 ppm ^{*1}
Methyl Ethyl Ketone	C ₄ H ₈ O	0.45 vol%	0 ppm
Methyl Isobutyl Ketone	C ₆ H ₁₂ O	0.30 vol%	0 ppm

Table 22: Interference Chart for ESR-A1CP-COH, H₂-Compensated CO Detection

Gas	Chemical Formula	Concentration	Indication Value
Methyl Methacrylate	C ₅ H ₈ O ₂	0.43 vol%	1 ppm
n-Hexane	n-C ₆ H ₁₄	0.30 vol%	1 ppm
Nonane	n-C ₉ H ₂₀	0.18 vol%	0 ppm
Ozone	O ₃	0.48 ppm	0 ppm
Phosphine	PH ₃	2.51 ppm	3 ppm
Propane	C ₃ H ₈	0.49 vol%	0 ppm
Propylene	C ₃ H ₆	0.50 vol%	78 ppm ^{*1}
Sulfur Dioxide	SO ₂	25.0 ppm	1 ppm
Tetrahydrofuran	C ₄ H ₈ O	0.50 vol%	1 ppm
Toluene	C ₇ H ₈	0.30 vol%	1 ppm
Xylene	C ₈ H ₁₀	0.25 vol%	0 ppm
^{*1} The indicated value may fluctuate when exposed to this gas.			

ESR-A1DP-COHS, CO Detection

Table 23: Interference Chart for ESR-A1DP-COHS, CO Detection

Gas	Chemical Formula	Concentration	Indication Value
Acetone	$(\text{CH}_3)_2\text{CO}$	0.538 vol%	-1 ppm
Acetylene	C_2H_2	99.6 ppm	84 ppm
Ammonia	NH_3	255 ppm	2 ppm
Arsine	AsH_3	1.1 ppm	4 ppm
Benzene	C_6H_6	0.3 vol%	-1 ppm
Carbon Dioxide	CO_2	100 vol%	8 ppm
Chlorine	Cl_2	0.8 ppm	-1 ppm
Cyclopentane	C_5H_{10}	0.35 vol%	0 ppm
Diborane	B_2H_6	5.25 ppm	2 ppm
Ethane	C_2H_6	0.75 vol%	0 ppm
Ethanol	$\text{CH}_3\text{CH}_2\text{OH}$	0.825 vol%	25 ppm ^{*1}
Ethyl Acetate	$\text{CH}_3\text{COOCH}_2\text{CH}_3$	0.525 vol%	9 ppm ^{*1}
Fluorine	F_2	1.6 ppm	0 ppm
Germane	GeH_4	10.2 ppm	7 ppm
Hydrogen	H_2	100 ppm	17 ppm
Hydrogen Chloride	HCl	11.7 ppm	-1 ppm
Hydrogen Cyanide	HCN	1.8 ppm	-1 ppm
Hydrogen Selenide	H_2Se	1 ppm	2 ppm
Hydrogen Sulfide	H_2S	30 ppm	2 ppm
Isobutane	C_4H_{10}	0.45 vol%	0 ppm
Isobuten	$(\text{CH}_3)_2\text{C}=\text{CH}_2$	1000 ppm	9 ppm
Isopropyl Alcohol	$(\text{CH}_3)_2\text{CHOH}$	0.5 vol%	15 ppm ^{*1}
Methane	CH_4	1.25 vol%	-1 ppm
Methanol	CH_3OH	1000 ppm	10 ppm ^{*1}
Methyl Ethyl Ketone	$\text{C}_4\text{H}_8\text{O}$	0.45 vol%	-1 ppm

Table 23: Interference Chart for ESR-A1DP-COHS, CO Detection

Gas	Chemical Formula	Concentration	Indication Value
Methyl Isobutyl Ketone	C ₆ H ₁₂ O	0.3 vol%	0 ppm
Methyl Methacrylate	C ₅ H ₈ O ₂	0.425 vol%	2 ppm
n-Heptane	CH ₃ (CH ₂) ₅ CH ₃	0.275 vol%	-1 ppm
n-Hexane	CH ₃ (CH ₂) ₄ CH ₃	0.3 vol%	0 ppm
Nitrogen Dioxide	NO ₂	50.5 ppm	1 ppm
Nitrogen Monoxide	NO	99.2 ppm	38 ppm
Nonane	CH ₃ (CH ₂) ₇ CH ₃	0.175 vol%	0 ppm
Ozone	O ₃	1.8 ppm	0 ppm
Phosphine	PH ₃	2.5 ppm	3 ppm
Propane	C ₃ H ₈	0.5 vol%	0 ppm
Propylene	C ₃ H ₆	0.5 vol%	42 ppm ^{*1}
Silane	SiH ₄	29.9 ppm	46 ppm
Sulfur Dioxide	SO ₂	30 ppm	3 ppm
Tetrahydrofuran	C ₄ H ₈ O	0.5 vol%	21 ppm
Toluene	C ₆ H ₅ CH ₃	0.3 vol%	0 ppm
Xylene	C ₆ H ₄ (CH ₃) ₂	0.25 vol%	0 ppm
^{*1} The indicated value may fluctuate when exposed to this gas.			

ESR-A1DP-COHS, H₂S Detection

Table 24: Interference Chart for ESR-A1DP-COHS, H₂S Detection

Gas	Chemical Formula	Concentration	Indication Value
Acetone	CH ₃ COCH ₃	0.538 vol%	-0.1 ppm
Acetylene	C ₂ H ₂	99.6 ppm	-0.1 ppm
Ammonia	NH ₃	250 ppm	-0.1 ppm
Arsine	AsH ₃	1.1 ppm	0.5 ppm
Benzene	C ₆ H ₆	0.3 vol%	-0.1 ppm
Carbon Dioxide	CO ₂	100 vol%	-0.1 ppm
Carbon Monoxide	CO	1000 ppm	2.6 ppm
Chlorine	Cl ₂	0.8 ppm	-0.1 ppm
Cyclopentane	C ₅ H ₁₀	0.35 vol%	-0.1 ppm
Diborane	B ₂ H ₆	5.25 ppm	0.2 ppm
Ethane	C ₂ H ₆	0.75 vol%	0.0 ppm
Ethanol	CH ₃ CH ₂ OH	0.825 vol%	0.5 ppm
Ethyl Acetate	CH ₃ COOCH ₂ CH ₃	0.525 vol%	-0.1 ppm
Fluorine	F ₂	1.6 ppm	-0.1 ppm
Germane	GeH ₄	10.2 ppm	0.3 ppm
Hydrogen	H ₂	2000 ppm	1.3 ppm
Hydrogen Chloride	HCl	11.7 ppm	-0.2 ppm
Hydrogen Cyanide	HCN	1.8 ppm	0.0 ppm
Hydrogen Selenide	H ₂ Se	1 ppm	0.3 ppm
Isobutane	C ₄ H ₁₀	0.45 vol%	-0.1 ppm
Isobuten	CH ₂ CH(CH ₃) ₂	1000 ppm	0.1 ppm
Isopropyl Alcohol	CH ₃ C(OH)CH ₃	0.5 vol%	0.0 ppm
Methane	CH ₄	1.25 vol%	-0.1 ppm
Methanol	CH ₃ OH	1.375 vol%	0.5 ppm

Table 24: Interference Chart for ESR-A1DP-COHS, H₂S Detection

Gas	Chemical Formula	Concentration	Indication Value
Methyl Ethyl Ketone	C ₄ H ₈ O	0.45 vol%	0.3 ppm
Methyl Isobutyl Ketone	C ₆ H ₁₂ O	0.3 vol%	-0.1 ppm
Methyl Methacrylate	C ₅ H ₈ O ₂	0.425 vol%	-0.1 ppm
n-Heptane	CH ₃ (CH ₂) ₅ CH ₃	0.275 vol%	-0.1 ppm
n-Hexane	CH ₃ (CH ₂) ₄ CH ₃	0.3 vol%	-0.1 ppm
Nitrogen Dioxide	NO ₂	50.5 ppm	-4.6 ppm
Nitrogen Monoxide	NO	99.2 ppm	6.0 ppm
Nonane	CH ₃ (CH ₂) ₇ CH ₃	0.175 vol%	0.2 ppm
Ozone	O ₃	1.8 ppm	-0.1 ppm
Phosphine	PH ₃	2.5 ppm	1.5 ppm
Propane	C ₃ H ₈	0.5 vol%	-0.1 ppm
Propylene	C ₃ H ₆	0.5 vol%	-0.1 ppm
Silane	SiH ₄	29.9 ppm	0.6 ppm
Sulfur Dioxide	SO ₂	30 ppm	-0.1 ppm
Tetrahydrofuran	C ₄ H ₈ O	0.5 vol%	0.1 ppm
Toluene	C ₆ H ₅ CH ₃	0.3 vol%	-0.1 ppm
Xylene	C ₆ H ₅ (CH ₃) ₂	0.25 vol%	-0.1 ppm

Warranty

RKI Instruments, Inc. warrants the GX-3R sold by us to be free from defects in materials, workmanship, and performance for a period of three years from the date of shipment from RKI Instruments, Inc. This includes the instrument and the original sensors. Replacement parts are warranted for 1 year from the date of their shipment from RKI Instruments, Inc. except for replacement sensors which are warranted for 3 years. Any parts found defective within their warranty period will be repaired or replaced, at our option, free of charge. This warranty does not apply to those items which by their nature are subject to deterioration or consumption in normal service, and which must be cleaned, repaired, or replaced on a routine basis. Examples of such items are:

- Absorbent cartridges
- Fuses
- Pump diaphragms and valves
- Batteries
- Filter elements, disks, or sheets

Warranty is voided by abuse including mechanical damage, alteration, rough handling, or repair procedures not in accordance with the instruction manual. This warranty indicates the full extent of our liability, and we are not responsible for removal or replacement costs, local repair costs, transportation costs, or contingent expenses incurred without our prior approval.

THIS WARRANTY IS EXPRESSLY IN LIEU OF ANY AND ALL OTHER WARRANTIES AND REPRESENTATIONS, EXPRESSED OR IMPLIED, AND ALL OTHER OBLIGATIONS OR LIABILITIES ON THE PART OF RKI INSTRUMENTS, INC. INCLUDING BUT NOT LIMITED TO THE WARRANTY OF MERCHANTABILITY OR FITNESS FOR A PARTICULAR PURPOSE. IN NO EVENT SHALL RKI INSTRUMENTS, INC. BE LIABLE FOR INDIRECT, INCIDENTAL, OR CONSEQUENTIAL LOSS OR DAMAGE OF ANY KIND CONNECTED WITH THE USE OF ITS PRODUCTS OR FAILURE OF ITS PRODUCTS TO FUNCTION OR OPERATE PROPERLY.

This warranty covers instruments and parts sold to users only by authorized distributors, dealers, and representatives as appointed by RKI Instruments, Inc. We do not assume indemnification for any accident or damage caused by the operation of this gas monitor and our warranty is limited to replacement of parts or our complete goods.



EU-Declaration of Conformity

Document No.: 320CE22069



We, RIKEN KEIKI Co., Ltd. 2-7-6, Azusawa, Itabashi-ku, Tokyo, 174-8744 Japan declare under our sole responsibility that the following product conforms to all the relevant provisions.

Product Name: Portable Gas Monitor
Model: GX-3R

Council Directives		Applicable Standards
2014/34/EU	ATEX Directive	EN IEC 60079-0:2018 EN 60079-1:2014 EN 60079-11:2012 EN 50303:2000
2014/30/EU	EMC Directive	EN 50270:2015
2011/65/EU ^[1]	RoHS Directive	EN IEC 63000:2018

^[1]Including substances added by Commission Delegated Directive (EU) 2015/863

EU-Type examination Certificate No. DEKRA 17ATEX0103 X

Notified Body for ATEX DEKRA Certification B.V. (NB 0344)
Meander 1051, 6825 MJ Arnhem
P.O.Box 5185, 6802 ED Arnhem
The Netherlands

Auditing Organization for ATEX DNV Product Assurance AS (NB 2460)
Veritasveien 1
1363 Høvik
Norway

The marking of the product shall include the following:



II 1 G Ex da ia IIC T4 Ga or Ex ia IIC T4 Ga and
I M1 Ex da ia I Ma or Ex ia I Ma

Alternative Marking: da ia:with thermo catalytic gas sensor NCR-6309
ia:without thermo catalytic gas sensor NCR-6309

Place: Tokyo, Japan

Date: Jun. 29, 2022

Takakura Toshiyuki
General manager
Quality Control Center



EU-Declaration of Conformity

Document No.: 320CE22053



We, RIKEN KEIKI Co., Ltd. 2-7-6, Azusawa, Itabashi-ku, Tokyo, 174-8744 Japan declare under our sole responsibility that the following product conforms to all the relevant provisions.

Product Name: Battery Charger
Model: BC-3R

Council Directives		Applicable Standards
2011/65/EU ^[1]	RoHS Directive	EN IEC 63000:2018

^[1]Including substances added by Commission Delegated Directive (EU) 2015/863

Place: Tokyo, Japan

Date: Jun. 29, 2022

Takakura Toshiyuki
General manager
Quality Control Center

GX-3R

1. Safety information

Necessary information for explosion proof construction of Model GX-3R.

Overview

The GX-3R can measure up to 4 gases using 3 sensors.

The GX-3R measures the combustible gases (LEL), oxygen (O₂), hydrogen sulfide (H₂S), and carbon monoxide (CO).

This model displays measurement results on an LCD and issue gas alarms (via LED and buzzer) as needed.

Gas sampling is by diffusion. The model does not have internal suction pumps.

Power sources

The GX-3R draws power from an integrated rechargeable Li-ion battery that is not user-replaceable.

A dedicated AC adapter is used for recharging the Li-ion battery.

Explosion proof structure	Intrinsically safe explosion-proof construction and flame-proof enclosures		
Specification for safety	Ex da ia I Ma , Ex da ia IIC T4 Ga (with combustible gas sensor NCR-6309) Ex ia I Ma , Ex ia IIC T4 Ga (without combustible gas sensor NCR-6309)		
	 I M1 Ex da ia I Ma, II 1 G Ex da ia IIC T4 Ga (with combustible gas sensor NCR-6309) I M1 Ex ia I Ma, II 1 G Ex ia IIC T4 Ga (without combustible gas sensor NCR-6309)		
Ambient temperature range	-40°C to +60°C		
Ambient temperature range (for charging)	0°C to +40°C		
Electrical data	<ul style="list-style-type: none">• Lithium-ion battery: Maxell rechargeable battery model no. ICP463048XS• The battery should be charged with the dedicated AC adapter or by power from a IEC60950-certified SELV power source, or IEC62368-1-certified ES1 power source. The maximum voltage from the charger shall not exceed 6.3Vdc.		
Certificate numbers	<ul style="list-style-type: none">• IECEx : IECEx DEK 17.0050 X• ATEX : DEKRA 17 ATEX 0103 X		
List of standards	<table><tr><td><ul style="list-style-type: none">• IEC 60079-0:2017• IEC 60079-1:2014-06• IEC 60079-11:2011</td><td><ul style="list-style-type: none">• EN IEC 60079-0:2018• EN60079-1:2014• EN60079-11:2012• EN50303:2000</td></tr></table>	<ul style="list-style-type: none">• IEC 60079-0:2017• IEC 60079-1:2014-06• IEC 60079-11:2011	<ul style="list-style-type: none">• EN IEC 60079-0:2018• EN60079-1:2014• EN60079-11:2012• EN50303:2000
<ul style="list-style-type: none">• IEC 60079-0:2017• IEC 60079-1:2014-06• IEC 60079-11:2011	<ul style="list-style-type: none">• EN IEC 60079-0:2018• EN60079-1:2014• EN60079-11:2012• EN50303:2000		



WARNING

- Do not attempt to disassemble or modify the instrument.
- The combustible gas sensor NCR-6309, to measure LEL, is the only part of this Gas Monitor system with flame - proof construction.
- This product is an explosion-proof product and is not to be disassembled or modified with the exception of specified parts.
- NCR-6309 must not be exposed to ultraviolet light.
- This product integrates a sensor having flameproof construction. If assembly is not performed as specified, explosion protection performance will be compromised. When replacing the sensor and filter, properly install genuine parts and torque to specification.
- If the enclosure is damaged it shall be repaired before further use.
- The Sensor shall not be exposed to ultraviolet light or used in equipment in which it is not fully enclosed.
- Do not charge in a hazardous location.
- Do not charge the unit with a non-genuine charger.

Group I Additional Specific Condition

- Do not give strong force or shock to NCR - 6309. There is a danger that the flame - proof performance will be damaged due to breakage etc. This sensor uses flame-proof conditions of "low" possibility of mechanical damage.
- The enclosures shall be protected against exposure to hydraulic liquids, oil or grease.

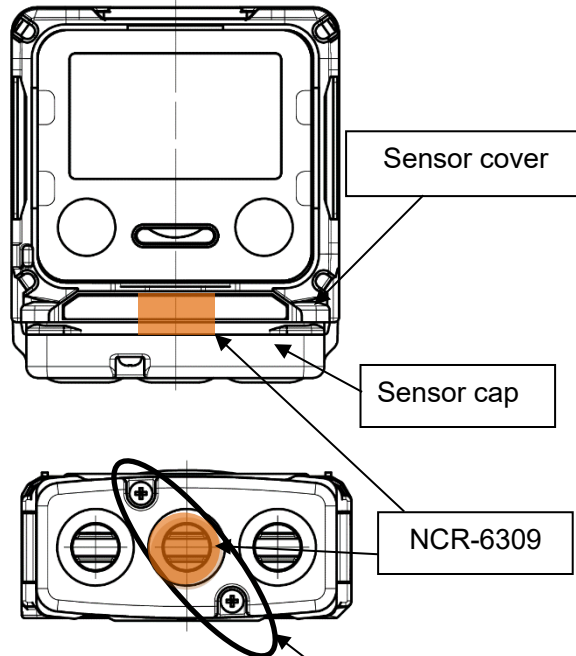

Location of screws for performing replacement

Tightening specification: At least 10 N·cm

Maximum sensor surface temperature 82.6°C

Instruments No.

INST. No. 00 0 000 0000 00
A B C D E

- A: Year of manufacture (0 to 9)
- B: Month of manufacture (1 to 9 for Jan.-Sep.; XYZ for Oct., Nov., Dec.)
- C: Manufacturing lot
- D: Serial number
- E: Factory codes



RIKEN KEIKI Co., Ltd.

2-7-6 Azusawa, Itabashi-ku, Tokyo, 174-8744, Japan

Phone: +81-3-3966-1113

Fax: +81-3-3558-9110

E-mail: intdept@rikenkeiki.co.jp

Website: <https://www.rikenkeiki.co.jp>