



**INSTRUMENTS**

**GX-2009**  
**Portable Gas Monitor**  
**Operator's Manual**

**Part Number: 71-0158RK**

**Revision: Q**

**Released: 6/5/20**

## **WARNING**

Read and understand this instruction manual before operating instrument. Improper use of the gas monitor could result in bodily harm or death.

Periodic calibration and maintenance of the gas monitor is essential for proper operation and correct readings. Please calibrate and maintain this instrument regularly! Frequency of calibration depends upon the type of use you have and the sensor types. Typical calibration frequencies for most applications are between 1 and 3 months, but can be required more often or less often based on your usage.

---

## Warranty

RKI Instruments, Inc. warrants the GX-2009 sold by us to be free from defects in materials, workmanship, and performance for a period of two years from the date of shipment from RKI Instruments, Inc. This includes the instrument and the original sensors. Replacement parts are warranted for 1 year from the date of their shipment from RKI Instruments, Inc except for sensors which are warranted for 2 years. Any parts found defective within their warranty period will be repaired or replaced, at our option, free of charge. This warranty does not apply to those items which by their nature are subject to deterioration or consumption in normal service, and which must be cleaned, repaired, or replaced on a routine basis. Examples of such items are:

Absorbent cartridges

Filter elements, disks, or sheets

Pump diaphragms and valves

Warranty is voided by abuse including mechanical damage, alteration, rough handling, or repair procedures not in accordance with the instruction manual. This warranty indicates the full extent of our liability, and we are not responsible for removal or replacement costs, local repair costs, transportation costs, or contingent expenses incurred without our prior approval.

THIS WARRANTY IS EXPRESSLY IN LIEU OF ANY AND ALL OTHER WARRANTIES AND REPRESENTATIONS, EXPRESSED OR IMPLIED, AND ALL OTHER OBLIGATIONS OR LIABILITIES ON THE PART OF RKI INSTRUMENTS, INC. INCLUDING BUT NOT LIMITED TO THE WARRANTY OF MERCHANTABILITY OR FITNESS FOR A PARTICULAR PURPOSE. IN NO EVENT SHALL RKI INSTRUMENTS, INC. BE LIABLE FOR INDIRECT, INCIDENTAL, OR CONSEQUENTIAL LOSS OR DAMAGE OF ANY KIND CONNECTED WITH THE USE OF ITS PRODUCTS OR FAILURE OF ITS PRODUCTS TO FUNCTION OR OPERATE PROPERLY.

This warranty covers instruments and parts sold to users only by authorized distributors, dealers, and representatives as appointed by RKI Instruments, Inc.

We do not assume indemnification for any accident or damage caused by the operation of this gas monitor and our warranty is limited to replacement of parts or our complete goods.

---

## Table of Contents

<b>Introduction</b> .....	<b>6</b>
<b>Specifications</b> .....	<b>7</b>
<b>Description</b> .....	<b>8</b>
Case.....	10
Alligator & Belt Clips.....	11
Sensor Retainer/Sensor Retainer Gasket/Sensor Cover Retainer.....	11
Scrubber Filters/Sensor Cover.....	11
Sensors.....	12
LCD.....	13
Control Buttons.....	13
Printed Circuit Boards.....	14
Alarm LED Arrays.....	14
Buzzer & Vibrator.....	14
NiMH Batteries.....	14
Charging Station.....	15
<b>Start Up</b> .....	<b>18</b>
Start-up Procedure.....	18
Performing a Fresh Air Adjustment.....	21
Turning Off the GX-2009.....	22
<b>Operation</b> .....	<b>23</b>
Normal Operation.....	23
Display Mode.....	23
Combustible Gas Detection.....	25
Alarms.....	26
Aspirator Adapter.....	30
<b>Data Logging</b> .....	<b>31</b>
<b>GX-2009 Setup Program</b> .....	<b>31</b>
<b>Calibration Mode</b> .....	<b>32</b>
Using Calibration Mode.....	33
Setting the Date & Time.....	34
Performing a Fresh Air Adjustment.....	34
Performing a Span Adjustment in AUTO CAL.....	35
Performing a Span Adjustment in ONE CAL.....	40
Performing a Bump Test in BUMP.....	44
Discharging the Batteries With the REFRESH Function.....	48

<b>User Setup Mode</b> .....	<b>50</b>
Using User Setup Mode .....	50
Setting the Date & Time .....	52
Performing a Fresh Air Adjustment .....	52
Performing a Span Adjustment in AUTO CAL .....	52
Performing a Span Adjustment in ONE CAL .....	52
Setting the Alarm Points .....	53
Setting the Password .....	54
<b>Maintenance</b> .....	<b>56</b>
Troubleshooting .....	56
Recharging the GX-2009's NiMH Batteries .....	57
Replacing the GX-2009's NiMH Batteries .....	60
Checking the Combustible Gas Sensor's Condition .....	62
Replacing the Scrubber Filters .....	63
Replacing the Sensor Cover .....	64
Replacing a Sensor .....	64
<b>Parts List</b> .....	<b>67</b>

---

**WARNING:** *Understand manual before operating. Substitution of components may impair intrinsic safety. To prevent ignition of a hazardous atmosphere, batteries must only be changed or charged in an area known to be nonhazardous. Not tested in oxygen enriched atmospheres (above 21%).*

---



---

**NOTE:** RKI Instruments, Inc. recommends that you refer to ISA-RP12.13, Part II-1987 or an equivalent international recommended practice for guidance in the use of combustible gas detection instruments.

---

---

## Introduction

Using an advanced detection system consisting of four gas sensors, the GX-2009 personal four-gas monitor detects the presence of combustible gas, oxygen (O<sub>2</sub>), carbon monoxide (CO), and hydrogen sulfide (H<sub>2</sub>S) simultaneously. The GX-2009's compact size and easy-to-use design makes it ideally suited for a wide range of applications, including sewage treatment plants, utility manholes, tunnels, hazardous waste sites, power stations, petrochemical refineries, mines, paper mills, drilling rigs, and fire fighting stations. The GX-2009 offers a full range of features, including:

- Simultaneous four-gas monitoring and display of combustible gases, O<sub>2</sub>, CO, and H<sub>2</sub>S
- Backlit LCD (liquid crystal display) for complete and understandable information at a glance
- Distinctive audible/vibrating alarms for dangerous gas conditions and audible alarms for unit malfunction
- Microprocessor control for reliability, ease of use, and advanced capabilities
- Resistance to RF (radio frequency) interference
- Datalogging including interval trend data and alarm trend data
- STEL/TWA and over range alarm display
- Peak hold readouts
- Built-in time function
- Lightweight and compact high impact plastic case
- Rotatable alligator clip for "hands-free" gas monitoring, belt clip optional
- CSA classified for Class I, Division I, Groups A, B, C, and D hazardous atmospheres

---

**WARNING:** *The GX-2009 detects oxygen deficiency and elevated levels of oxygen, combustible gases, carbon monoxide, and hydrogen sulfide, all of which can be dangerous or life threatening. When using the GX-2009, you must follow the instructions and warnings in this manual to assure proper and safe operation of the unit and to minimize the risk of personal injury. Be sure to maintain and periodically calibrate the GX-2009 as described in this manual.*


---

**NOTE:** Only the combustible gas detector portion of this instrument has been assessed for performance.

---

# Specifications

**Table 1: Model GX-2009 Specifications**

Target Gas	Combustible Gas, Methane (CH <sub>4</sub> ) calibration standard*	Oxygen (O <sub>2</sub> )	Hydrogen Sulfide (H <sub>2</sub> S)	Carbon Monoxide (CO)
Range (Increment)	0-100% LEL (1% LEL)	0-40.0 vol% (0.1 vol%)	0-100.0 ppm (0.5 ppm)	0-500 ppm (1 ppm)
Detection Method	Diffusion			
Response Time	T90 Within 30 Seconds			
Accuracy	± 5% of reading or ± 2% LEL (whichever is greater)	± 0.5% O <sub>2</sub>	± 5% of reading or ± 2 ppm H <sub>2</sub> S (whichever is greater)	± 5% of reading or ± 5 ppm CO (whichever is greater)
Display	Digital LCD			
Gas Alarms (Factory Settings)	Alarm 1: 10% LEL Alarm 2: 50% LEL Over: 100% LEL	Alarm 1: 19.5 vol% (Decreasing) Alarm 2: 23.5 vol% Over: 40.0 vol%	Alarm 1: 5.0 ppm Alarm 2: 30.0 ppm Over: 100.0 ppm TWA: 1.0 ppm STEL: 5.0 ppm	Alarm 1: 25 ppm Alarm 2: 50 ppm Over: 300 ppm TWA: 25 ppm STEL: 200 ppm
Operating Temperature and Humidity	-20 to 50° C/Below 85% RH (Without Condensation)			
Safety/Regulatory	 C US 186718 CSA classified, "C/US", as Intrinsically Safe. Exia. Class I, Groups A, B, C, & D. Class I, Zone 0, Group IIC. Temperature Code T3C.			
Power Supply	NiMH Batteries (2.4 VDC Nominal), Direct Charging			
Continuous Operating Hours	Up to 20 Hours (Non Alarm Operation After Full Charge)			
Charge Time	3 hours for a full charge			
Case	High-impact Plastic, Dust and Water Resistant to IP-67			
Required Accessories	AC or DC Charging Station, AC Charging Station Available For From 1 to 5 Instruments			
Other Accessories	<ul style="list-style-type: none"> <li>• IrDA/USB cable for downloading data to computer</li> <li>• Product CD, includes GX-2009 Data Logger Management Program and GX-2009 Setup Program</li> <li>• SDM-2009 Automatic Calibration Station</li> <li>• Hand Aspirated Sample Draw Adapter with Hose and Probe</li> <li>• Wrist Strap (included with every unit)</li> </ul>			

**Table 1: Model GX-2009 Specifications**

Dimensions and Weight	Dimensions: 2.7 H, 3.0 W, 1.0 D inches Approx. 70 H, 75 W, 25 D mm Weight: 4.6 oz.
*The GX-2009 is also available set up for general hydrocarbons and calibrated to a combustible gas other than methane, such as isobutane. Consult RKI Instruments, Inc. for further information.	

---

**NOTE:** The bump test function in Calibration Mode is included in instruments with firmware version 03955 or later installed. See page 44 for a description of the bump test function. GX-2009 instruments shipped after May 2011 include the bump test function. Instruments that have a serial number starting with 04516 or later shipped from the factory with the bump test function available. Instruments that have a serial number starting with 04515 did not include the bump test function when shipped from the factory. The factory setting for the bump test function is off.

---



## Description

This section describes the GX-2009's components and the charging station. These components include the GX-2009's case, alligator and belt clips, sensor retainer, sensor retainer gasket, sensor cover retainer, scrubber filters, sensor cover, sensors, LCD, control buttons, printed circuit boards, alarm LED arrays, buzzer, vibrator, batteries, and charging station.

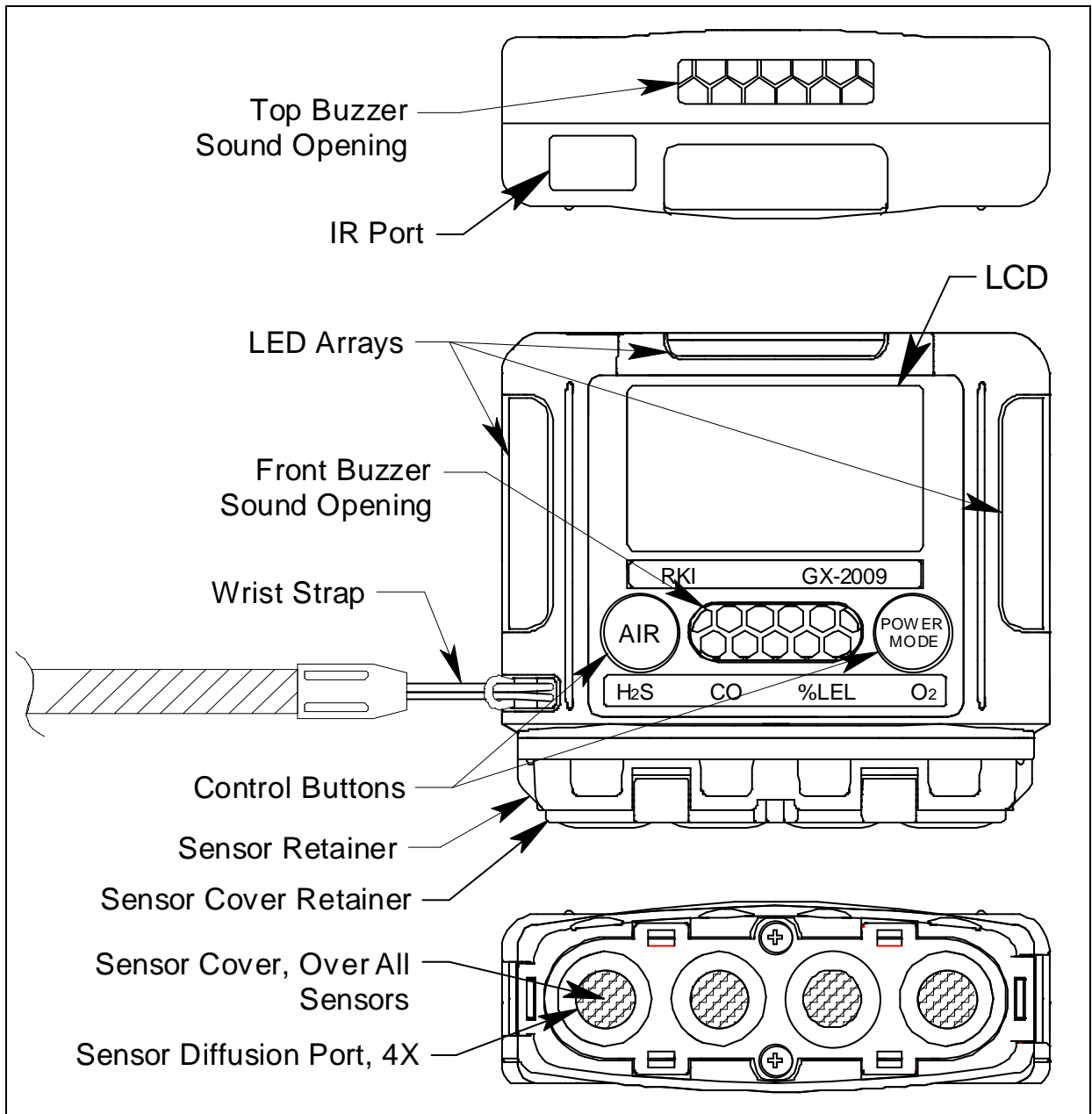
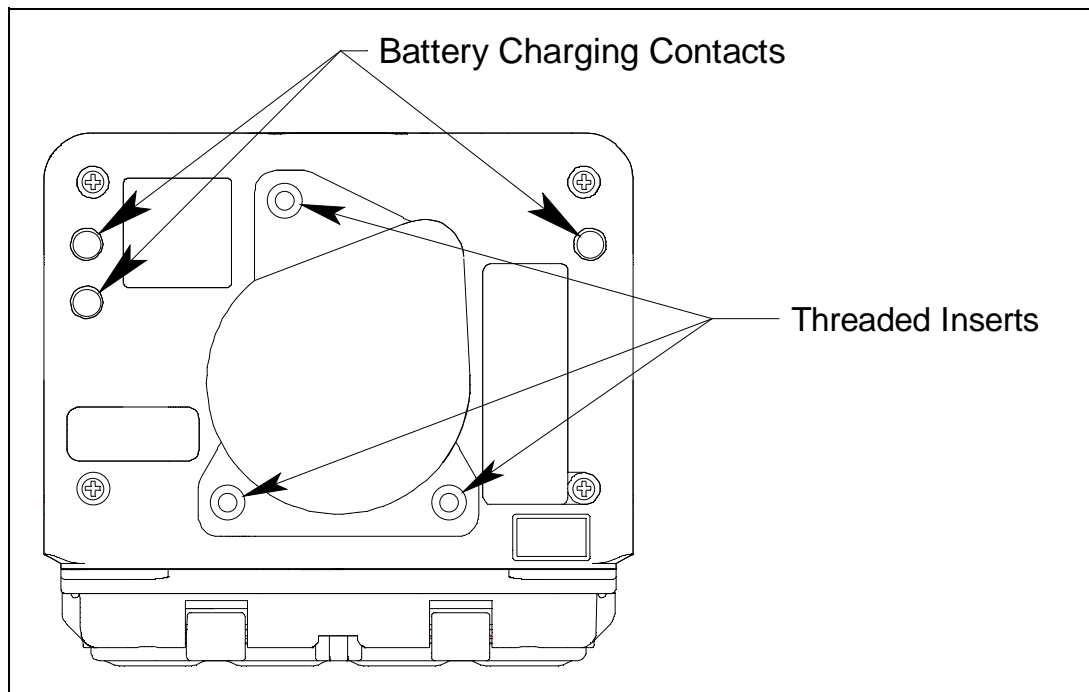


Figure 1: Top, Front & Bottom Views



**Figure 2: GX-2009 Rear View**

## Case

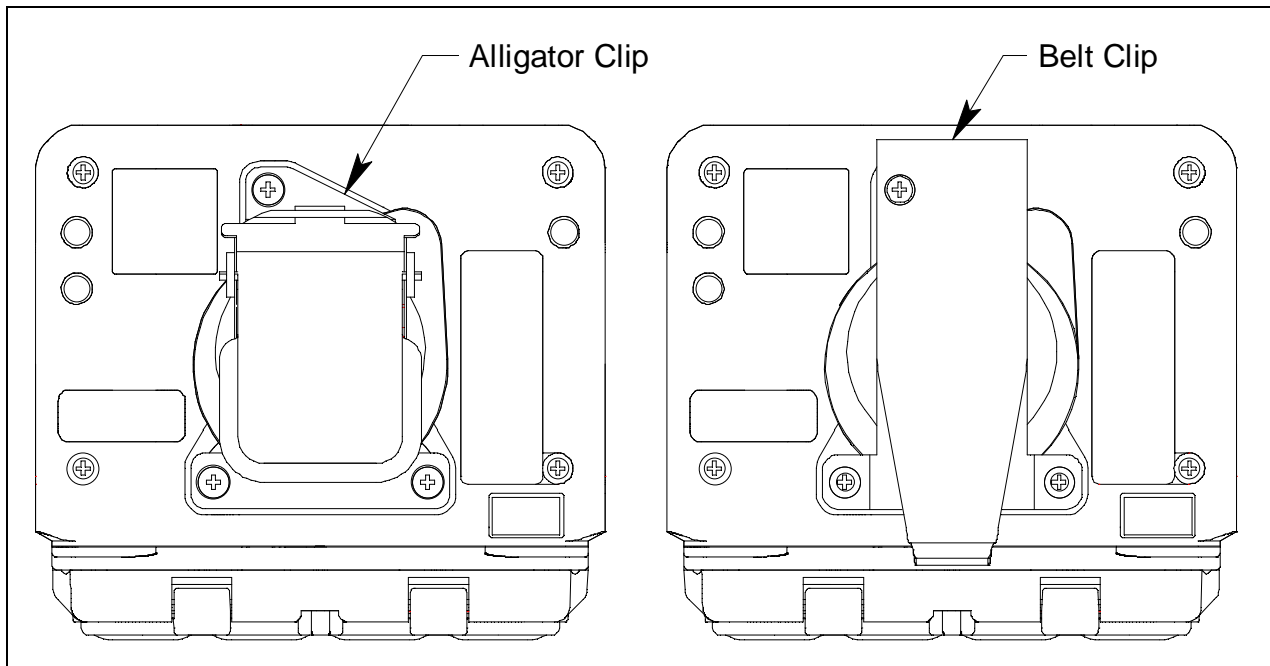
The GX-2009's sturdy, high-impact plastic case is suitable for use in many environmental conditions, indoors and out. The unit is dust proof and water resistant. Rubber overmolded surfaces on much of the case help protect it from impact damage and aid in holding the instrument in your hand.

A clear plastic window through which the LCD can be viewed is located on the front of the case. Three brass charging contacts that are used when the GX-2009 is placed in the charging station are on the back of the case. Four sensor diffusion ports are located on the bottom of the case. The ports are labelled as follows from left to right: H<sub>2</sub>S, CO, HC, and O<sub>2</sub>. Three frosted windows, one on the left side, one of the right side, and one on top, cover alarm LED arrays. There are two buzzer sound openings, one on the front below the LCD and one on the top behind the top LED array. An IR (infrared) communication port is located on the top left side which is used to transfer information when the instrument is used with one of the calibration or downloading accessories.

There are three threaded inserts on the back of the case. These are used to mount the alligator clip or the optional belt clip.

## Alligator & Belt Clips

The GX-2009 is available with two types of clips, the standard alligator clip and the optional belt clip. Both are illustrated in Figure 3.



**Figure 3: Alligator and Belt Clips**

The alligator clip can be used to attach the GX-2009 to clothing or a belt. Teeth in the alligator clip's jaws prevent the unit from slipping off. The alligator clip can be rotated to change how the instrument is oriented when worn. The belt clip is used to easily clip the GX-2009 on a belt.

## Sensor Retainer/Sensor Retainer Gasket/ Sensor Cover Retainer

The sensor retainer holds the gas sensors in place and snaps onto the bottom of the case. It has 4 diffusion ports, one for each sensor, and has recessed areas in it for the charcoal filter, and the H<sub>2</sub>S removal filters. It also has indexing features for the sensor retainer gasket. The sensor retainer gasket seats onto the sensor retainer and seals the interface between the sensor retainer, sensor cover, and sensor cover retainer. The sensor cover retainer snaps onto the sensor retainer. Two screws secure the sensor retainer and the sensor cover retainer to the case.

## Scrubber Filters/Sensor Cover

### *Charcoal Filter Disk*

The charcoal filter disk is located in the CO sensor diffusion port of the sensor retainer. It is black, has a woven texture, and is impregnated with an H<sub>2</sub>S absorbing material. It fits into a recessed area of that port. The CO sensor will respond if exposed to H<sub>2</sub>S and certain hydrocarbon gasses. The charcoal filter scrubs these gasses out of the gas sampled to avoid false CO readings. The H<sub>2</sub>S absorbing material added to the charcoal filter extends its H<sub>2</sub>S

absorbing life. If false CO readings are noticed, especially high readings in the presence of H<sub>2</sub>S, change the charcoal filter disk.

### ***H<sub>2</sub>S Removal Filter Disks***

One H<sub>2</sub>S removal filter disk is located in a recessed area of the combustible gas sensor diffusion port in the sensor retainer. It prevents H<sub>2</sub>S in the ambient air from reaching the unit's combustible gas sensor. Removing H<sub>2</sub>S that is present in the monitored air prolongs the life of the sensor. The H<sub>2</sub>S filter disk is dark red in color and although it may darken over time, its color is not indicative of remaining filter life. The H<sub>2</sub>S filter disk can absorb H<sub>2</sub>S for 33 ppm hours and should be replaced after that much exposure. With this many ppm hours of absorption, the H<sub>2</sub>S filter disk should be replaced after 80 minutes of exposure to 25 ppm H<sub>2</sub>S. This equates to replacing the H<sub>2</sub>S filter disk after 40 2-minute calibrations with a cylinder containing 25 ppm H<sub>2</sub>S. If H<sub>2</sub>S exists in the monitoring environment, the H<sub>2</sub>S filter disk will have to be replaced more frequently.

### ***Sensor Cover***

The sensor cover is white and protects the scrubber filters and sensors from dust and water. It fits on the sensor retainer gasket over all the sensor diffusion ports and is secured in place by the sensor cover retainer. If the sensor cover becomes dirty, the response time and accuracy of the GX-2009 will be affected. Replace the sensor cover if it appears dirty.

## **Sensors**

The GX-2009 uses four sensors to monitor combustible gases, O<sub>2</sub>, CO, and H<sub>2</sub>S simultaneously. The sensors are protected from the environment by the sensor cover which allows ambient air to diffuse to the sensors. The sensors use different detection principles, as described below.

### ***Combustible Gas (LEL) Sensor***

The combustible gas sensor detects combustible gas and vapors in the LEL (lower explosive limit) range with a catalytic element. A sintered metal flame arrestor covers the element and allows ambient air to diffuse into the sensor. The reaction of gas with oxygen on the catalyst causes a change in the resistance of the element which affects the current flowing through it. The current is amplified by the GX-2009's circuitry, converted to a measurement of combustible gas concentration, and displayed on the LCD.

---

***CAUTION:*** *Do not expose the combustible sensor to high concentrations of combustible gas such as that from a butane lighter. Exposure to high concentrations of combustible gas may adversely affect the performance of the sensor.*

---

## Oxygen (O<sub>2</sub>) Sensor

The O<sub>2</sub> sensor is a galvanic type sensor. A membrane covers the cell and allows gas to diffuse into the cell at a rate proportional to the partial pressure of oxygen. The oxygen reacts in the cell and produces a voltage proportional to the concentration of oxygen. The voltage is measured by the GX-2009's circuitry, converted to a measurement of gas concentration, and displayed on the LCD.

## CO and H<sub>2</sub>S Sensors

The CO and H<sub>2</sub>S sensors are electrochemical sensors that consist of two precious metal electrodes in an acid electrolyte. A gas permeable membrane covers the sensor face and allows gas to diffuse into the electrolyte. The gas reacts in the sensor and produces a current proportional to the concentration of the target gas. The current is amplified by the GX-2009's circuitry, converted to a measurement of gas concentration, and displayed on the LCD.

## LCD

The LCD (liquid crystal display) is visible through the GX-2009's front window. Target gas concentrations, the time, battery condition, and alarm indications are displayed on the LCD. When either of the control buttons are pressed, the LCD backlight comes on for 30 seconds.

## Control Buttons

Two control buttons are located below the display on either side of the front buzzer opening. The AIR button is on the left and the POWER MODE button is on the right. The functions performed by the control buttons are summarized in the following table:

**Table 2: GX-2009 Control Buttons**

Button	Function
POWER MODE	<ul style="list-style-type: none"><li>• Turns the unit on and off</li><li>• Turns the LCD back light on</li><li>• Scrolls through Display Mode</li><li>• Resets the alarm circuit (gas alarms)</li><li>• Enters Calibration Mode with the AIR button</li><li>• Enters User Setup Mode with the AIR button</li><li>• Selects a displayed item</li><li>• Saves adjusted parameters</li><li>• Selects displayed parameters</li></ul>
AIR	<ul style="list-style-type: none"><li>• Turns the LCD back light on.</li><li>• Performs a fresh air adjustment</li><li>• Enters Calibration Mode with the MODE POWER button.</li><li>• Enters User Setup Mode with the MODE POWER button.</li><li>• Adjusts or changes displayed parameters</li></ul>

## Printed Circuit Boards

The primary function of the GX-2009's printed circuit boards is to amplify the signal sent to them from the four gas sensors, convert the signal to a measurement of gas concentration, display the gas concentration on the LCD, store peak, STEL, and TWA readings, and activate the alarm circuit if an alarm point has been reached. They monitor battery level, battery failure, and sensor failure. They also control the GX-2009's time function and various operating modes.

---

**NOTE:** The printed circuit boards contain no user serviceable parts.

---

## Alarm LED Arrays

Three red alarm LED (light emitting diode) arrays are visible through frosted plastic lenses in the case. One is on the top, one on the left side, one on the right side of the case. The alarm LED arrays alert you to gas, low battery, and failure alarms.

## Buzzer & Vibrator

A solid-state electronic buzzer is mounted inside the GX-2009's case. The buzzer sounds for gas alarms, failure alarms, and as an indicator during normal use of the GX-2009's various operating modes.

A vibrating motor inside the GX-2009 case vibrates for gas alarms and as an indicator during normal use of the GX-2009's various operating modes.

## NiMH Batteries

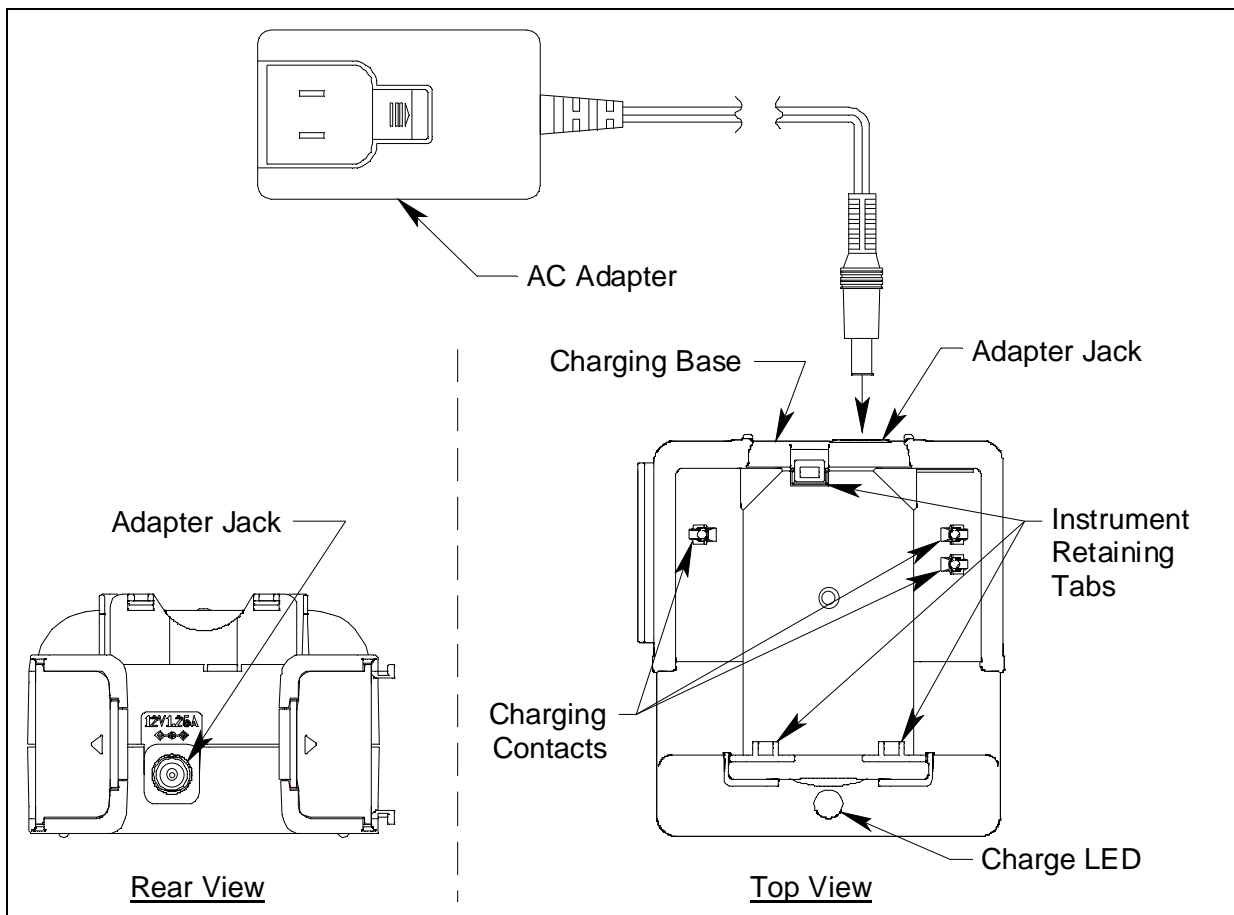
Two NiMH (nickel metal hydride) batteries, each with an integral holder, supply 2.4 volts to power the GX-2009. The batteries will run the unit for up to 20 hours when no alarms have been activated during that time period. The batteries are designed to be charged while in the GX-2009 with the GX-2009 Charging Station. The batteries should not be removed from the GX-2009 unless they need to be replaced because they will no longer hold a charge. The battery icon in the lower left corner of the LCD shows the charge remaining in the batteries. See "Recharging the GX-2009's NiMH Batteries" on page 57 for instructions to recharge the batteries and "Replacing the GX-2009's NiMH Batteries" on page 60 for instructions to replace the batteries.

## Charging Station

The GX-2009's NiMH batteries are charged with the GX-2009 Charging Station. There are two types of charging stations available, the standard AC powered charging station and the optional vehicle plug DC powered charging station.

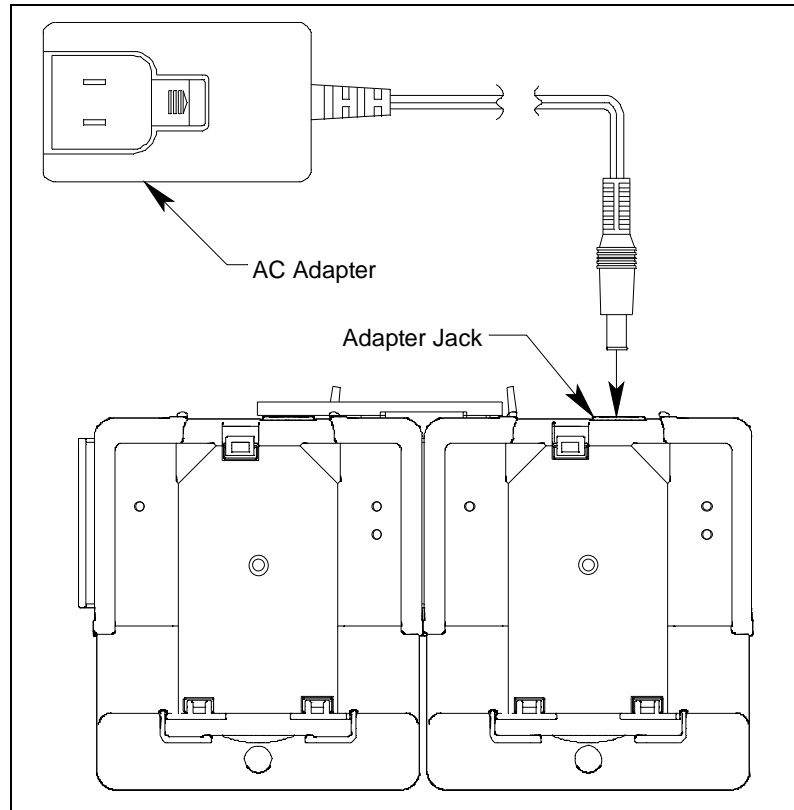
### AC Powered Charging Station

The standard AC powered charging station is available in configurations that charge from one to five instruments at a time. The single instrument charging station consists of one instrument charging base and an AC adapter. The AC adapter for the standard charging station plugs into a 115 VAC wall outlet and connects to the charging station with a jack on the end of a five foot DC output cable. The AC adapter will also work for 100 VAC or 220 VAC if an appropriate plug adapter is provided. The single instrument AC charging station is shown in Figure 4.

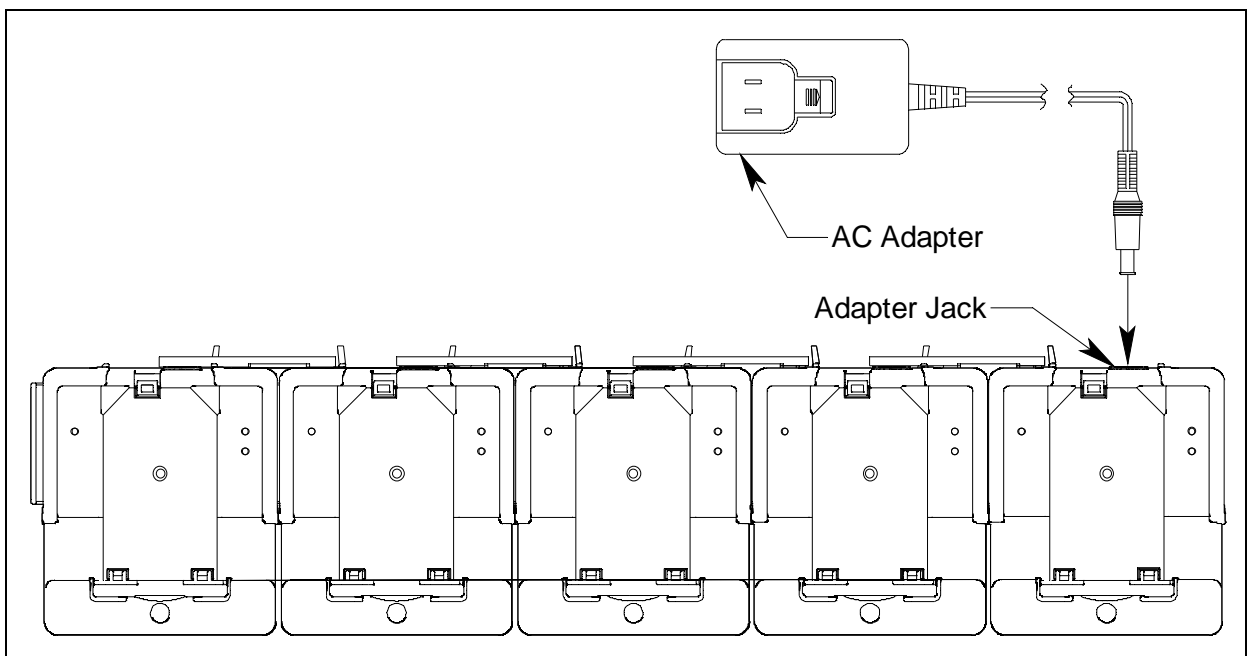


**Figure 4: GX-2009 Charging Station, Single Instrument Station**

Charging stations for more than one instrument include additional chargers that are attached to each other. The same AC adapter can power up to a maximum of 5 charging bases. The two instrument charging station is shown in Figure 5, and the five instrument station is shown in Figure 6.



**Figure 5: GX-2009 Charging Station, Two Instrument Station**

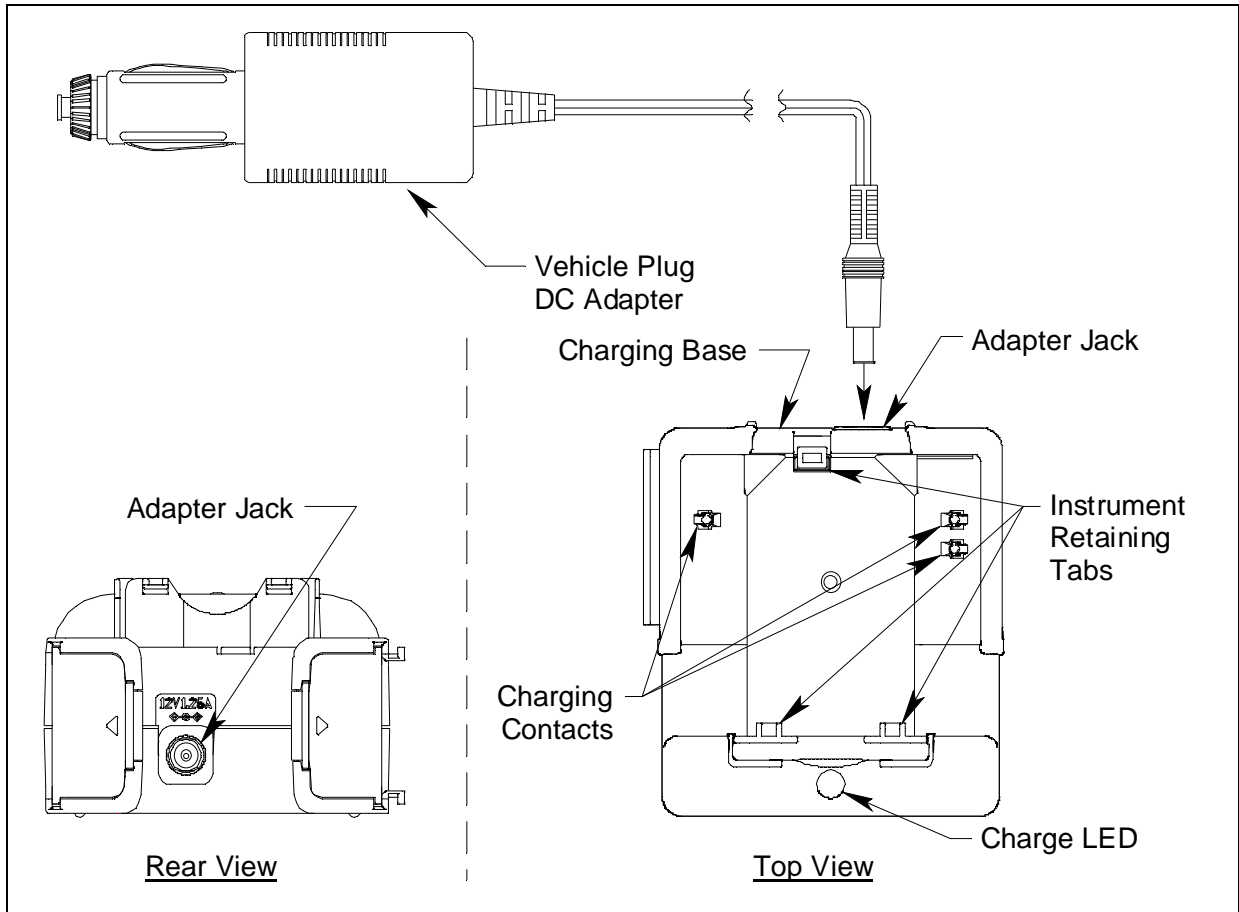


**Figure 6: GX-2009 Charging Station, Five Instrument Station**



## DC Powered Charging Station

An optional DC powered single instrument charging station is available with a vehicle plug 12 VDC adapter. The DC adapter for the charging station can only provide enough power to charge one instrument at a time, so the DC powered charging station is only available as a single instrument charging station. It uses the same charging base as the AC powered charging station.



**Figure 7: GX-2009 DC Powered Charging Station**

---

## Start Up

This section explains how to start up the GX-2009 and get it ready for operation.

### Start-up Procedure

1. Press and briefly hold down the POWER MODE button. The backlight will turn on and all the display segments will turn on. Release the button when you hear a beep.
2. The vibrator vibrates and the alarm lights flash momentarily.
3. If **Cal. Limit Display** is turned on, the screen that appears next depends on how **Cal. Limit Check** is set. These parameters and the **Auto Zero Adjustment** parameter mentioned in Step 9 below cannot be set using the GX-2009's instrument menus, but are set using the GX-2009 Setup Program. See the GX-2009 Setup Program Operator's Manual for information regarding changing various instrument parameters that are not available for adjustment in the instrument's operating modes.
  - If the unit is due for calibration and **Cal. Limit Check** is set to *Confirm to use*, then the following screen displays.



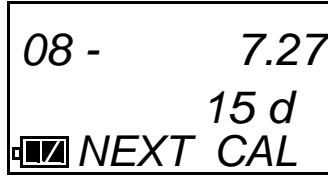
The alarm LED's and buzzer will pulse several times. After this, press and release the POWER MODE button. You will hear a beep and startup sequence will continue.

- If the unit is due for calibration and **Cal. Limit Check** is set to *Can't use*, then the following screen displays.



The alarm LED's and buzzer will pulse several times. This screen will then remain on the display until the unit is turned off. The GX-2009 cannot be used until a complete calibration has been performed either by selecting AUTO CAL or ONE CAL in the Calibration Mode menu. See "Performing a Span Adjustment in AUTO CAL" on page 35 or "Performing a Span Adjustment in ONE CAL" on page 40 for calibration instructions.

- If calibration is not due or **Cal. Limit Check** is set to *None*, then the following screen appears for a few seconds indicating when the next calibration is due.



---

**NOTE:** The following screen only appears if **Bump Test Limit Display** is set to On using the User Setup Program. The standard factory setting for this function is Off.

---

4. If **Bump Test Limit Display** is set to On using the User Setup Program, the next screen will depend on how **Bump Limit Check** is set using the User Setup Program.
  - If the unit is due for bump testing and **Bump Test Limit Check** is set to *Confirm to use*, then the following screen displays.



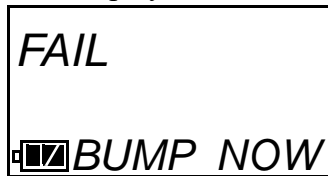
The alarm LED's and buzzer will pulse several times. After this, press and release the POWER MODE button. You will hear a beep and startup sequence will continue.

---

**WARNING:** *You must press the POWER MODE button to continue to normal operation. If you do not press the POWER MODE button, the buzzer will continue to beep and the LEDs will continue to flash for 6 seconds every 5 seconds and the unit will not enter normal operation.*

---

- If the unit is due for bump testing and **Bump Test Limit Check** is set to *Can't use*, then the following screen displays.



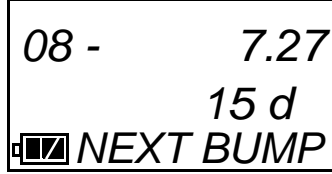
The alarm LED's and buzzer will pulse several times. This screen will then remain on the display until the unit is turned off. The GX-2009 cannot be used until a bump test has been performed. See "Performing a Bump Test in BUMP" on page 44 for bump test procedures.

---

**WARNING:** *You must perform a bump test in order to continue to normal operation. If you do not perform a bump test, the buzzer will continue to beep and the LEDs will continue to flash for 6 seconds every 5 seconds and the unit will not enter normal operation.*

---

- If bump testing is not due or **Bump Test Limit Check** is set to *None*, then the following screen appears for a few seconds indicating when the next bump test is due.

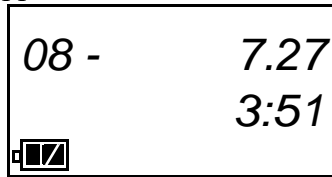



---

**NOTE:** If a successful calibration is performed, the next bump test date is reset and starts over even though a bump test was not performed.

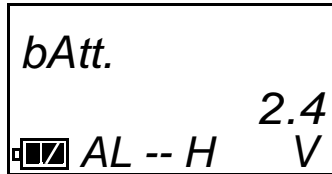
---

5. The Date/Time Screen appears for a few seconds.



This screen displays the current date and time.

6. The Battery Voltage/Alarm Pattern Screen appears for a few seconds.



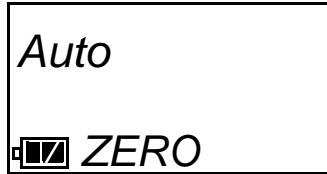
The screen displays the current battery voltage and the alarm pattern. AL -- H indicates latching alarms and AL -- A indicates self-resetting alarms. See “Alarm Logic/Resetting Alarms” on page 27 for a description of latching and self-resetting alarms.

7. The display then indicates the following items for about a second each:
  - Full scale values for all channels
  - Warning setpoint (low gas alarm) for all channels
  - Alarm setpoint (high gas alarm) for all channels
  - STEL alarm setpoint for the CO and H<sub>2</sub>S channels
  - TWA alarm setpoint for the CO and H<sub>2</sub>S channels
8. If the GX-2009 experiences a sensor failure during start up, a screen indicating which sensor failed displays. In the example below, the CO sensor has failed.



If you wish to continue, press and release the POWER MODE button to acknowledge the failure. The gas reading for the failed sensor will be replaced by “- -”. Replace the failed sensor as soon as possible.

9. If **Auto Zero Adjustment** is set to *On*, then the GX-2009 will perform an automatic fresh air adjustment.



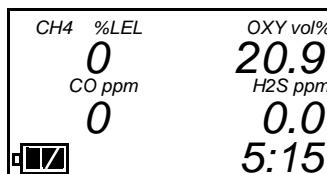
If the fresh air adjustment is successful, the unit will proceed to Normal Mode. If one or more of the sensors fails the fresh air adjustment, the display will indicate which sensor or sensors failed. If a failure occurs, press and release the POWER MODE button to proceed to Normal Mode. The gas reading for the failed sensor or sensors will be replaced by “- -”. Replace any sensors that fail the automatic fresh air adjustment as soon as possible.

---

**WARNING:** *If the Auto Zero Adjustment feature is turned on, make sure that you start-up the GX-2009 in a known fresh air environment, an environment free of combustible or toxic gasses and of normal oxygen content, 20.9%. If you do not start-up the unit in a fresh air environment, the fresh air adjustment will not be accurate.*

---

10. The GX-2009 is now operating in Measuring Mode and monitoring for gas. The Normal Operation Screen appears.



The concentrations of the target gasses are displayed along with the time in the lower right corner and the battery charge level in the lower left corner.

## Performing a Fresh Air Adjustment

Before using the GX-2009, set the fresh air reading. Performing this adjustment ensures accurate gas readings in the monitoring environment as long as the calibration is current.

1. Find a fresh-air environment. This is an environment free of toxic or combustible gasses and of normal oxygen content (20.9%).
2. With the unit on and in the Normal Operation Screen, press and hold the AIR button. The LCD displays the following screen prompting you to keep pressing the AIR button.



3. After a few seconds the LCD displays the following screen prompting you to release the AIR button.



4. The unit will take a few seconds to adjust the fresh air readings, then return to the Normal Operation Screen.

### **Turning Off the GX-2009**

1. Press and hold the POWER MODE button for about three seconds to turn off the unit. The buzzer will sound and the LCD back light will turn on.
2. Release the button when the LCD is blank. The unit is off.

---

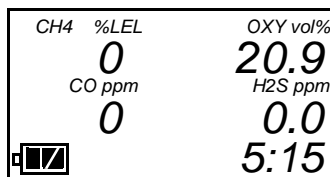
## Operation

This section describes the operation of the GX-2009 in Measuring Mode. It explains how enter Display Mode to view the peak gas readings of the four target gasses, the STEL and TWA readings for H<sub>2</sub>S and CO, and the full scale detection range value for each target gas. It covers important issues regarding combustible gas detection. It also covers alarm indications and use of the aspirator adapter accessory.

### Normal Operation

When the GX-2009 comes out of its startup sequence, see “Start Up” on page 18, it enters Measuring Mode and is in normal operation if no alarm indications are taking place. It is advisable to perform a fresh air adjustment when the GX-2009 comes out of its startup sequence as described in “Start Up”. If **Auto Zero Adjustment** is set to *On*, be sure to follow the guidelines in Step 9 in “Start-up Procedure” on page 18.

In the Normal Operation Screen of Measuring Mode, the battery level, time, and gas concentrations for each channel are displayed on the LCD. The time is in the lower right corner and the battery level is in the lower left corner. Combustible gas is displayed as a percentage of the lower explosive limit (%LEL), oxygen is displayed as a volume percentage (vol%), H<sub>2</sub>S and CO as parts per million (ppm). The combustible channel gas name is CH<sub>4</sub> if it is calibrated to methane (CH<sub>4</sub>) or HC if it is calibrated to a another combustible gas. See “Combustible Gas Detection” on page 25 for a discussion of the combustible channel gas name and calibration.



### Display Mode

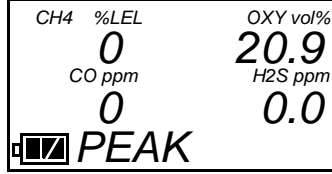
You can access Display Mode while in Measuring Mode by using the POWER MODE button. In Display Mode you can view and reset the peak readings for each target gas, view the TWA and STEL values for CO and H<sub>2</sub>S, and view the detection range full scale for each target gas.

STEL is an acronym for short-term exposure limit, and it is the average reading of the target gas during the last 15 minutes. TWA is an acronym for time-weighted average, and it is the average reading for the target gas during the last eight (8) hours. If eight (8) hours has not elapsed since the unit was turned on, the TWA is still calculated over eight hours, with the missing time assigned a zero (0) value for the readings. Similarly, if the unit has not been on for 15 minutes, the missing time is assigned a 0 value and the STEL is calculated over 15 minutes. The peak readings, STEL values, and TWA values are cleared when the unit is turned off.

To enter Display Mode and view items or reset the peak readings, do the following:

1. Make sure the GX-2009 is in the Measuring Mode Normal Operation screen. The GX-2009 must be in the Normal Operation Screen for you to access Display Mode.

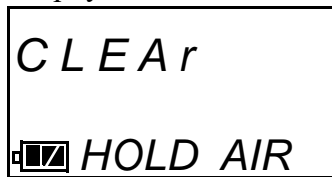
2. Press and release the POWER MODE button to enter Display Mode. The backlight will turn on and the PEAK Screen will appear.



The peak readings since the GX-2009 was turned on are displayed for combustible gas, CO, and H<sub>2</sub>S. The minimum reading is displayed for oxygen.

3. If you do not want to clear the peak readings, continue to the next step.

If you want to clear the peak readings, press and hold the AIR button. After a couple of seconds, the LCD will prompt you to hold the AIR button with the following screen.



Hold the AIR button until the following screen appears, then release it.



The peak readings will be cleared and the unit will return to the PEAK Screen.

4. Press and release the POWER MODE button again to proceed to the STEL Screen. The STEL values for CO and H<sub>2</sub>S are displayed.
5. Press and release the POWER MODE button again to proceed to the TWA Screen. The TWA values for CO and H<sub>2</sub>S are displayed.
6. Press and release the POWER MODE button again to proceed to the Full Scale Screen. The detection range full scale value for each channel is displayed.
7. Press and release the POWER MODE button again to return to Measuring Mode.

---

**NOTE:** If you do not press a button for 20 seconds while in Display Mode, the GX-2009 will return to Measuring Mode automatically and the backlight will turn off 30 seconds since the last button was pressed.

---



## Combustible Gas Detection

There are three issues that must be considered when monitoring for combustible gas.

- The combustible sensor will respond to any combustible gas. The standard calibration gas for the GX-2009 combustible channel is methane (CH<sub>4</sub>). If the instrument is calibrated to a different combustible gas, such as hexane or propane, the gas name for the combustible channel may be set to HC by using the GX-2009 Setup Program. See the GX-2009 Setup Program Operator's Manual for information on how to set the combustible gas name.

The table below lists the conversion factors for several hydrocarbon gasses **if the GX-2009 is calibrated to methane**. To use this table, multiply the display reading on the combustible gas channel by the factor in the appropriate row to obtain the actual gas concentration. For example, if you are detecting pentane and the display reads 10% LEL on the combustible channel, you actually have 10% LEL x 1.56 = 15.6% LEL pentane present.

**Table 3: LEL Hydrocarbon Conversions**

Gas	LEL Conversion Factor (CH <sub>4</sub> Cal.)	Gas	LEL Conversion Factor (CH <sub>4</sub> Cal.)
Acetone	1.79	Iso Butane	1.47
Acetylene	1.92	MEK	2.27
Benzene	2.00	Methane	1.00
Ethane	1.09	Methanol	1.92
Ethanol	2.50	Pentane	1.56
Ethylene	1.06	Propane	1.35
Heptane	2.50	Propylene	1.32
Hexane	2.08	Toluene	3.13
Hydrogen	1.25	Xylene	4.27
IPA	2.78		

- The GX-2009 provides the combustible sensor with some protection against exposure to high levels of combustible gas. It does this by turning off the combustible sensor power temporarily when it determines that an over scale (more than 100% LEL) concentration of combustible gas is present that may damage the sensor. Nevertheless, concentrations of combustible gas of more than 100% LEL can still affect the zero level or calibration of the combustible sensor if the concentration is high enough.

---

**CAUTION:** Do not expose the combustible sensor to high concentrations of combustible gas such as that from a butane lighter. Exposure to high concentrations of combustible gas may adversely affect the performance of the sensor.

---

---

**CAUTION:** Any rapid increase in the combustible gas reading followed by a declining or erratic reading may indicate a gas concentration above the LEL which may be hazardous.

---

- Some gases such as silicone vapors, chlorinated hydrocarbons, and sulphur compounds can contaminate the detection elements inside the combustible sensor damaging the sensor and resulting in reduced response to combustible gas. Make every effort to avoid these gases. The H<sub>2</sub>S scrubber disks protect the combustible sensor from H<sub>2</sub>S, but you should avoid other sulphur compounds.

## Alarms

This section covers alarm indications. It also describes the two types of alarm logic, how to reset the GX-2009 after an alarm has occurred, and how to respond to an alarm condition.

---

**NOTE:** False alarms may be caused by radio frequency (RF) or electromagnetic (EMI) interference. Keep the GX-2009 away from RF and EMI sources such as radio transmitters or large motors.

---

### Alarm Indications

The GX-2009 will sound an alarm, the LEDs will flash, and the unit will vibrate when one of the target gas concentrations rises above the Warning (low alarm) setpoint, or in the case of oxygen falls below the Warning setpoint, for that gas.

The GX-2009 will also sound an alarm, the LEDs will flash, and the unit will vibrate when the Alarm (high alarm) setpoint is reached for any of the channels and when the STEL and TWA alarm points are reached for CO and H<sub>2</sub>S.

When a trouble condition occurs, such as a sensor failure or low battery charge, the alarm indication will depend on the alarm type.

Table 4 below summarizes the types of alarms produced by the GX-2009.

**Table 4: Alarm Types and Indications**

Alarm Type	Visual Indications	Other Indications
<u>Warning (low alarm)</u> Concentration of gas rises above the Warning setpoint or falls below the Warning setpoint for O <sub>2</sub>	<ul style="list-style-type: none"><li>• <b>WARNING</b> blinks to the right of the battery level icon</li><li>• Reading for the gas in alarm flashes</li><li>• Alarm LEDs flash</li><li>• Backlight turns on</li></ul>	<ul style="list-style-type: none"><li>• Buzzer sounds alternating between a low and high pitch</li><li>• Vibrator pulses</li></ul>

**Table 4: Alarm Types and Indications**

Alarm Type	Visual Indications	Other Indications
<u>Alarm (high alarm)</u> Concentration of gas rises above the Alarm setpoint	<ul style="list-style-type: none"> <li>• <b>ALARM</b> flashes to the right of the battery level icon faster than Warning indication</li> <li>• Reading for the gas in alarm flashes faster than Warning indication</li> <li>• Alarm LEDs flash faster than Warning indication</li> <li>• Backlight turns on</li> </ul>	<ul style="list-style-type: none"> <li>• Buzzer sounds alternating between a low and high pitch faster than Warning indication</li> <li>• Vibrator pulses faster than Warning indication</li> </ul>
<u>TWA or STEL</u> Concentration of CO or H <sub>2</sub> S rises above the TWA or STEL alarm point setting	<ul style="list-style-type: none"> <li>• <b>TWA</b> or <b>STEL</b> flashes to the right of the battery level icon</li> <li>• The gas name in alarm flashes</li> <li>• Alarm LEDs flash</li> <li>• Backlight turns on</li> </ul>	<ul style="list-style-type: none"> <li>• Buzzer sounds alternating between a low and high pitch at the same rate as Warning indication</li> <li>• Vibrator pulses at same rate as Warning indication</li> </ul>
<u>Over Range</u> Concentration of gas rises above full scale	<ul style="list-style-type: none"> <li>• <b>OVER</b> flashes to the right of the battery level icon at the same rate as Alarm indication</li> <li>• Gas reading replaced by brackets flashing at the same rate as Alarm indication □□□□</li> <li>• Alarm LEDs flash at the same rate as Alarm indication</li> <li>• Backlight turns on</li> </ul>	<ul style="list-style-type: none"> <li>• Buzzer sounds alternating between a low and high pitch at same rate as Alarm indication</li> <li>• Vibrator pulses at same rate as Alarm indication</li> </ul>
Low Battery Warning	<ul style="list-style-type: none"> <li>• Battery icon blinks</li> </ul>	None
Dead Battery Alarm	<ul style="list-style-type: none"> <li>• Gas readings replaced by <b>FAIL</b> in the upper left corner of LCD</li> <li>• <b>BATTERY</b> is displayed to the right of the battery icon.</li> <li>• Battery icon blinks</li> <li>• LEDs flash</li> </ul>	Buzzer pulses
Sensor Failure	<ul style="list-style-type: none"> <li>• Name of failed sensor or sensors displayed.</li> <li>• <b>FAIL</b> is displayed</li> <li>• LEDs flash</li> </ul>	Buzzer sounds a double pulsing tone (two pulses in quick succession)

**Alarm Logic/Resetting Alarms**

The gas alarm logic can be set to either latching or self resetting with the GX-2009 Setup Program by setting the **Alarm Pattern** parameter. See the GX-2009 Setup Program Operator’s Manual for information on how to set the alarm logic. If **Alarm Pattern** is set to *Latch*, the gas alarms are latching. If **Alarm Pattern** is set to *Reset*, the gas alarms are self-resetting. The standard factory setting is *Latch* for latching alarms.

If the alarms are latching, then an alarm indication will continue even if the gas reading causing the alarm decreases below the alarm setpoint (increases above for oxygen Warning) and will continue until the alarm is reset. To be able to reset the alarm, the gas reading that

caused the alarm must decrease below the alarm setpoint (increase above for oxygen Warning) before that alarm can be reset. To reset latching alarms, press and release the POWER MODE button after the gas reading falls below the alarm setpoint (or above for oxygen Warning).

If the alarms are self-resetting, then an alarm condition will automatically reset when the gas reading that caused the alarm decreases below the alarm setpoint (increases above for oxygen Warning).

If a STEL or TWA alarm has been activated, it cannot be reset. You must turn off the unit to clear the alarm.

### ***Responding to Alarms***

This section describes response to gas, over range, battery, and sensor failure alarms.

#### ***Responding to Gas Alarms***

1. Determine which gas alarm has been activated.
2. Follow your established procedure for an increasing gas condition or a decreasing oxygen condition.
3. If your unit is set for latching alarms, reset the alarm using the POWER MODE button once the alarm condition has been cleared.

#### ***Responding to Over Range Alarms***

---

***WARNING: An over range condition may indicate an extreme combustible gas, toxic gas, or oxygen content condition. Take immediate action and confirm the gas levels in the area with a different GX-2009 or with another gas detecting device.***

---

1. Determine which channel is indicating the alarm.
2. Follow your established procedure for an increasing gas condition.
3. Reset the alarm using the POWER MODE button once the alarm condition has cleared.
4. Calibrate the GX-2009 as described in “Performing a Span Adjustment in AUTO CAL” on page 35 or “Performing a Span Adjustment in ONE CAL” on page 40.
5. If the over range condition continues, replace the sensor that has triggered the over range alarm.
6. If the over range condition continues after you have replaced the sensor, contact RKI Instruments, Inc. for further instructions.

### Responding to Battery Alarms

---

**WARNING:** *The GX-2009 is not operational as a gas monitoring device during a dead battery alarm. Take the GX-2009 to a non-hazardous area and recharge the battery as described in “Recharging the GX-2009’s NiMH Batteries” on page 57*

---

The GX-2009 is fully functional during a low battery warning. However, depending upon conditions, the GX-2009 has only two or three hours of operating time left after the low battery warning has been triggered. Recharge the battery pack as soon as possible as described in “Recharging the GX-2009’s NiMH Batteries” on page 57.

---

**NOTE:** Alarms and the back light feature consume battery power and reduce the amount of operating time remaining.

---

### Responding to Sensor Failure Alarms

1. Determine which sensor has triggered the sensor failure alarm.
2. Try calibrating the sensor first as described in “Performing a Span Adjustment in AUTO CAL” on page 35 or “Performing a Span Adjustment in ONE CAL” on page 40 before replacing it.
3. If the sensor failure continues, replace the sensor as described in “Replacing a Sensor” on page 64.
4. If the sensor failure condition continues after you have replaced the sensor, contact RKI Instruments, Inc. for further instructions.

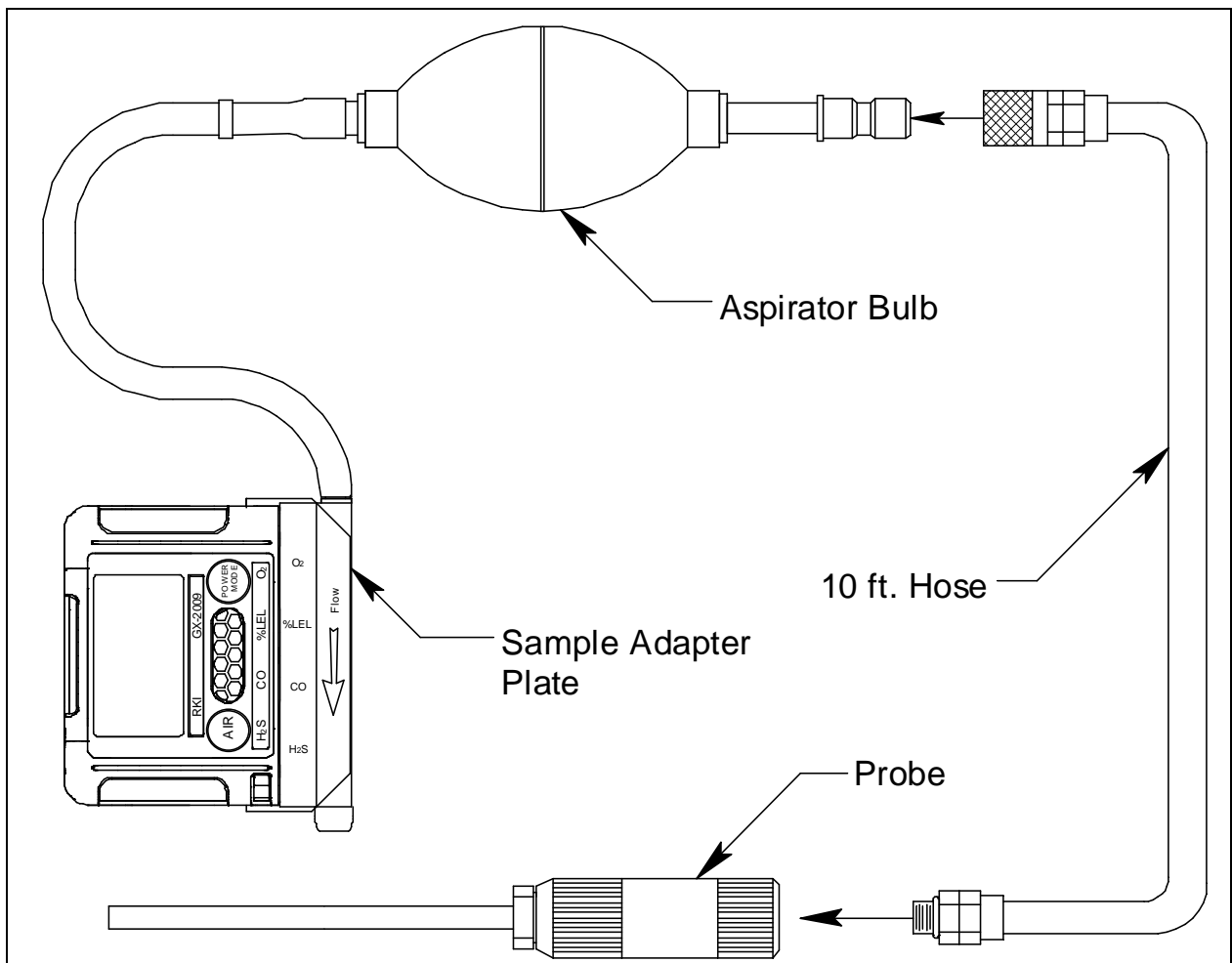
## Aspirator Adapter

The aspirator adapter accessory is used when it is necessary to draw sample from an area that cannot be entered or that must be checked for safety before entry, such as a tank or confined space.

---

**NOTE:** The CSA combustible performance certification for the GX-2009 does not include the aspirator adapter.

---



**Figure 8: GX-2009 Aspirator Adapter**

1. Turn on the GX-2009 as directed in “Start Up” on page 18.
2. Attach the sample adapter plate to the sensor side of the instrument.
3. Screw the probe onto the threaded end of the 10 ft. hose.
4. Attached the 10 ft. hose and probe to the aspirator bulb.

5. Insert the end of the probe into the area to be sampled.
6. Squeeze and release the aspirator bulb 15 times.

Monitor the readings and note if any alarms occur. The readings will peak shortly after the last squeeze and may decrease before all the channels can be checked. To see the maximum readings for each channel, display the peak readings for each channel in Display Mode (see “Display Mode” on page 23).

---

**NOTE:** The peak readings for each channel are saved until a higher peak is recorded, the peak readings are reset, or the instrument is turned off. If a gas is present but the level does not exceed the previous peak level, the previous peak will be displayed on the Peak Reading Screen.

---

---

## Data Logging

The GX-2009 features the ability to log data to its internal memory and download it to a computer via the infrared communications port on the top left side. It logs gas readings during normal operation, alarm data, calibration data, and bump test data.

To utilize the GX-2009’s downloading capability, you will need the GX-2009 Data Logger Management Program and a computer with an infrared port or a USB port that runs one of the following operating systems: Windows 7, Windows 8, or Windows 10. If your computer has an infrared port, then no additional accessories are needed to download data from the GX-2009. If your computer does not have an infrared port but does have a USB port, a USB/IrDA adapter cable can be used to download data from the GX-2009 using the USB port. The GX-2009 Data Logger Management Program is available at [www.rkiinstruments.com/gx2009](http://www.rkiinstruments.com/gx2009). The USB/IrDA adapter cable is also available from RKI.

See the GX-2009 Data Logging Management Program Operator’s Manual for a complete description of the GX-2009 Data Logging Management Program and procedures for downloading data to a computer.

---

## GX-2009 User Setup Program

There are some instrument operating parameters that are not accessible in either Calibration Mode or User Setup Mode such as the calibration frequency, auto zero function, and the alarm logic (latching or self resetting). Many of these parameters either do not typically need to be accessed once the GX-2009 is shipped from the factory or may only need to be accessed once because of operator preferences. These parameters can be accessed and updated if necessary using the GX-2009 User Setup Program, a computer with the same requirements described above in “Data Logging”, and a USB/IrDA cable if necessary. The GX-2009 User Setup Program is available at [www.rkiinstruments.com/gx2009](http://www.rkiinstruments.com/gx2009). The USB/IrDA adapter cable is also available from RKI.

See the GX-2009 User Setup Program Operator’s Manual for a complete description of the GX-2009 User Setup Program and procedures for accessing and updating instrument operating parameters.

---

## Calibration Mode

This section describes the GX-2009 in Calibration Mode. In Calibration Mode, you can move through a menu of screens to do the following:

- Set the date and time
- Perform a fresh air adjustment (part of a calibration)
- Perform a span adjustment on all channels simultaneously (part of a calibration)
- Perform a span adjustment on one channel at a time (part of a calibration)
- Perform a bump test (if **Bump Test Function** is set to *On* using the GX-2009 User Setup Program)
- Discharge the batteries with the REFRESH function

---

**NOTE:** You can set the GX-2009 to alert you during the startup sequence when calibration or bump testing is due with the GX-2009 User Setup Program. See the GX-2009 User Setup Program Operator's Manual for information on setting the **Cal. Limit Display** and **Bump Limit Display** parameters.

---

---

**CAUTION:** *BEFORE EACH DAY'S USAGE SENSITIVITY IN THE % LEL RANGE MUST BE TESTED ON A KNOWN CONCENTRATION OF THE COMBUSTIBLE TARGET GAS, TYPICALLY METHANE, EQUIVALENT TO 25 - 50% OF FULL SCALE CONCENTRATION (The %LEL full scale is 100% LEL). ACCURACY MUST BE WITHIN -0 to + 20% OF ACTUAL. ACCURACY MAY BE CORRECTED BY FOLLOWING THE CALIBRATION INSTRUCTIONS FOR THE COMBUSTIBLE CHANNEL BELOW.*

---

If the combustible channel passes the above response test and does not require calibration, the unit should still be calibrated periodically. The optimum frequency of calibration depends heavily on how the GX-2009 is used. For example, instruments used daily may need to be calibrated weekly or monthly, while instruments that are used only a few times a year may need to be calibrated before each use. Typical calibration frequencies range from monthly to quarterly. Make sure to perform the combustible channel response test as described above and make sure to develop a calibration schedule tailored to your application that takes this test and required calibration resulting from this test into account.



## Using Calibration Mode

---

**WARNING:** *The GX-2009 is not in operation as a gas detector while in Calibration Mode. Although it will respond to gas in parts of AIR CAL, AUTO CAL, ONE CAL, and BUMP TEST, there are no gas alarm indications.*

---

1. Take the GX-2009 to a non-hazardous area and turn it off if it is on.
2. Press and hold the AIR button, then press and hold the POWER MODE button. When you hear a beep release the buttons. The first menu item in Calibration Mode displays, the DATE Screen.



3. Use the AIR button to move forward through Calibration Mode. When you get to the last menu item, the START menu item, continuing will take you back to the beginning of the menu.
4. When you arrive at the item you wish to enter, press and release the POWER MODE button to enter that item.
5. When you need to adjust the numerical value of a parameter, increase it or decrease it, use the AIR button to change the value. When adjusting a numerical parameter value, it is possible to reverse the direction of adjustment. To switch from increasing to decreasing a value or decreasing to increasing a value, do the following:
  - with the parameter flashing on the screen, press and hold the AIR button
  - immediately press the POWER MODE button and then release both buttons
  - the direction of adjustment when you press the AIR button is now reversed
6. When you are done using the menu items in Calibration Mode, use the AIR button to scroll through the menu items to the START item.



7. At the START screen, press and release the POWER MODE button. The GX-2009 will begin its start-up sequence.

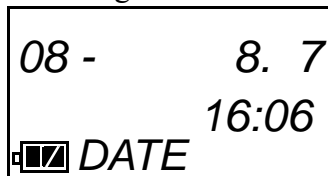
The Calibration Mode menu items are described below in the order in which they appear while moving through Calibration Mode.

## Setting the Date and Time

Entering the DATE menu item allows you to set the date and time.



1. When the DATE Screen is displayed, press and release the POWER MODE button. A screen appears with the year flashing in the upper left, the month and day in the upper right, and the time in the lower right.



2. Use the AIR button to display the desired year.
3. Press and release the POWER MODE button to save the setting. The month setting flashes.
4. Repeat steps 2 and 3 to enter the month, day, hour and minute setting. When you save the minute setting, you return to the DATE Screen.

## Performing a Fresh Air Adjustment

Entering the AIR CAL menu item allows you to perform a fresh air adjustment.



Perform a fresh air adjustment in Calibration Mode when you are performing a calibration before proceeding either to the AUTO CAL or ONE CAL menu item to perform a span adjustment. A fresh air adjustment performed in Calibration Mode is the same as a fresh air adjustment in Normal Mode. The AIR CAL menu item is available in Calibration Mode for convenience when performing a complete calibration.

---

**WARNING:** *Calibrate the GX-2009 in a non-hazardous environment.*

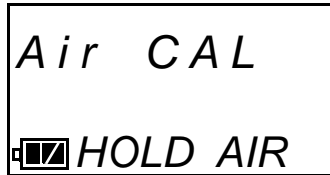
---

1. Find a fresh air environment, an environment of normal oxygen content (20.9%) that is free of toxic and combustible gasses.

- When the AIR CAL screen is displayed, press and release the POWER MODE button. A screen appears that displays the current gas readings and prompts you to press the AIR button by displaying the “PUSH AIR” message at the bottom of the screen.



- Press and hold the AIR button. The LCD prompts you to continue to hold the AIR button.



- Release the AIR button when the following screen appears.



- The unit will take a few seconds to adjust the fresh air readings, then indicate “END” to the right of the battery icon and return to the AIR CAL Screen.

## Performing a Span Adjustment in AUTO CAL

Entering the AUTO CAL menu item allows you to perform a span adjustment on all channels simultaneously.



Perform a span adjustment as part of a calibration after performing a fresh air adjustment. Performing a span adjustment requires the use of a calibration kit. The procedure below describes a span adjustment of all four channels using a calibration kit that includes a 4-gas calibration cylinder, a 0.5 LPM (liters per minute) regulator, a calibration adapter plate, and non-absorbent sample tubing. The standard 4-gas cylinder consists of 50% LEL methane, 12% oxygen, 25 ppm H<sub>2</sub>S, 50 ppm CO, and a balance of nitrogen. If the H<sub>2</sub>S channel on your GX-2009 is active, then use a 4-gas cylinder. If the H<sub>2</sub>S channel on your GX-2009 is not active, you may use a 3-gas cylinder to adjust the span. The standard 3-gas cylinder consists of 50% LEL methane, 12% oxygen, 50 ppm CO, and a balance of nitrogen. See “Parts List” on page 67 for available calibration kits and calibration kit spare parts.

---

**NOTE:** If the combustible gas channel is calibrated to a gas other than methane, such as isobutane, use an appropriate multigas cylinder or use single calibration to calibrate the combustible channel.

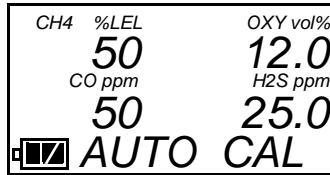
---

---

**WARNING: Calibrate the GX-2009 in a non-hazardous environment.**

---

1. Before performing a span adjustment, perform a fresh air adjustment as described in “Performing a Fresh Air Adjustment” on page 34.
2. At the AUTO CAL screen, press and release the POWER MODE button. A screen appears that displays the calibration gas concentrations that the GX-2009 expects you to use.



If the displayed concentrations match the calibration cylinder concentrations, continue with Step 3.

If any of the displayed concentrations do not match the calibration cylinder concentrations or if you want to turn off the AUTO CAL function for a channel or channels, do the following:

- Press and hold the AIR button, then press and momentarily hold the POWER MODE button.
- Release both buttons as soon as you hear the buzzer sound a beep. The following screen will display.



- You can scroll through all the channels by pressing and releasing the AIR button.
- When the desired channel is displayed, press and release the POWER MODE button to select the channel for a calibration gas value update. In the example below, the combustible channel has been selected and the current calibration gas value is 50 %LEL.



- Use the AIR button to adjust the calibration gas value to the desired value.

- If you want to turn the AUTO CAL function for the selected channel off so that a span adjustment will not be performed on this channel, set the calibration gas value to OFF by adjusting the reading down from the lowest value or up from the highest value.



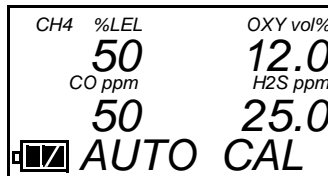
- Press and release the POWER MODE button to accept the displayed value. The previous screen will return.



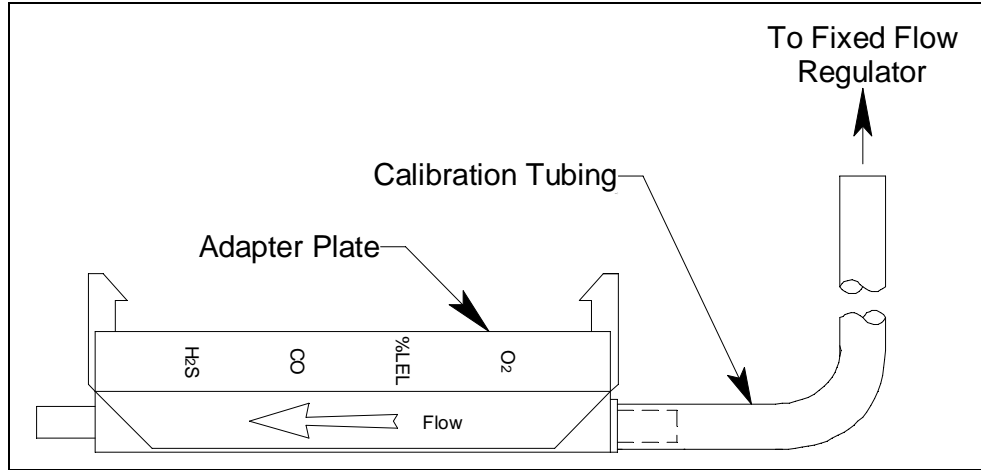
- Repeat the steps above for any other channels that require calibration gas value updates.
- When you are done updating calibration gas values, use the AIR button to scroll to the following screen.



- Press and release the POWER MODE button to return to the screen that displays the calibration gas values.

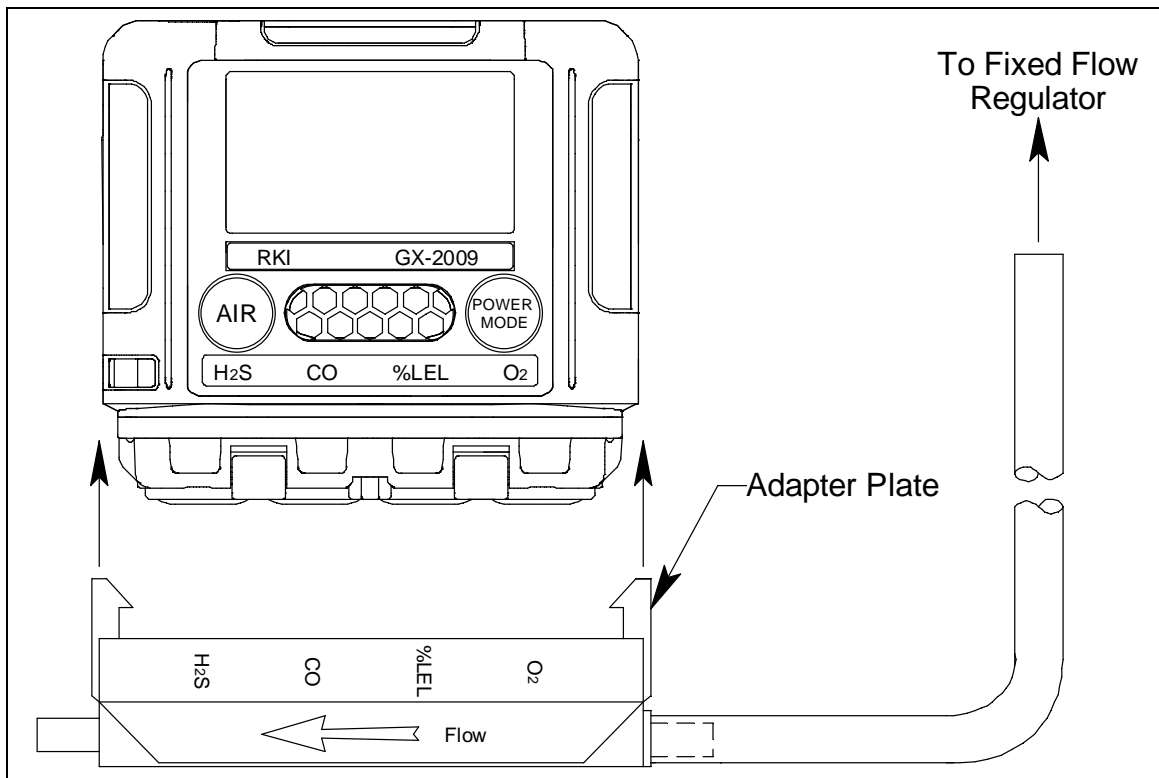


3. Use the sample tubing to connect the calibration adapter plate to the regulator. Attach the tubing to the adapter plate on the inlet side as shown below in Figure 9.



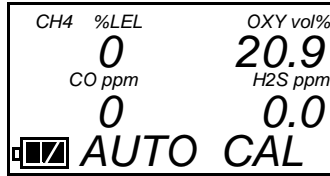
**Figure 9: Calibration Kit Assembly**

4. Push the adapter plate onto the GX-2009's sensor face. Make sure the adapter plate is oriented as shown in Figure 10 below with the sensor names on the adapter plate matching up with the sensor names on the instrument.

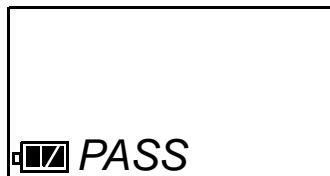


**Figure 10: Installing the Adapter Plate, Auto Cal**

5. Press and release the POWER MODE button. The LCD will display the current gas readings and “AUTO CAL” will flash.



6. For toxic gas cylinders (like cylinders containing H<sub>2</sub>S), it is important to vent the regulator while installing it onto the cylinder. Venting the regulator during installation helps prevent air from getting into the cylinder and degrading the gas. Open the regulator by turning the knob counterclockwise and install it onto the cylinder.
7. Allow the gas to flow for two minutes.
8. Press and release the POWER button.
9. The GX-2009 will attempt to make a span adjustment on all channels.
10. If the span adjustment is successful, the LCD will show the following screen before returning to the AUTO CAL screen.



11. If the span adjustment fails, the LCD will show the following screen indicating which channel or channels failed, the alarm LEDs will flash, and the buzzer will sound a double pulsing tone.



In this example, the CH4 channel failed the span adjustment. Press and release the POWER MODE button to clear the failure indication and return to the AUTO CAL screen.



See “Troubleshooting” on page 56 to investigate the cause of the failure and replace the failed sensor or sensors if necessary.

12. Turn the regulator on/off knob clockwise to close it.
13. Remove the calibration adapter plate from the instrument.
14. Remove the regulator from the calibration gas cylinder.

15. Leave the regulator connected to the calibration adapter plate for convenience.

16. Store the components of the calibration kit in a safe and convenient place.

## Performing a Span Adjustment in ONE CAL

Entering the ONE CAL menu item allows you to perform a span adjustment on one channel at a time. This feature is useful for situations when you do not need to calibrate all channels, such as when you are replacing a sensor.



Perform a span adjustment as part of a calibration after performing a fresh air adjustment. Performing a span adjustment requires the use of a calibration kit. The procedure below describes a span adjustment of one channel using a calibration kit that includes a 4-gas calibration cylinder, a 0.5 LPM (liters per minute) regulator, a calibration adapter plate, and non-absorbent sample tubing. The standard 4-gas cylinder consists of 50% LEL methane, 12% oxygen, 25 ppm H<sub>2</sub>S, 50 ppm CO, and a balance of nitrogen. If the H<sub>2</sub>S channel on your GX-2009 is active, then use a 4-gas cylinder so that you can calibrate all channels when necessary. If the H<sub>2</sub>S channel on your GX-2009 is not active, you may use a 3-gas cylinder. The standard 3-gas cylinder consists of 50% LEL methane, 12% oxygen, 50 ppm CO, and a balance of nitrogen. In the example below, the CH<sub>4</sub> channel's span is adjusted. See "Parts List" on page 67 for available calibration kits and calibration kit spare parts.

Calibration cylinders that contain only one target gas may also be used for single calibration. For channels other than oxygen, RKI Instruments, Inc. recommends that you use a cylinder that contains a concentration of 10-50% of the full scale value of the target gas. For example, if you are calibrating the combustible gas channel, your calibration cylinder should have a combustible gas concentration between 10% LEL and 50% LEL. For the oxygen channel, RKI Instruments, Inc. recommends using 100% nitrogen to perform the adjustment but any concentration between 0% oxygen (100% nitrogen) and 17% oxygen can be used to make the adjustment.

---

**NOTE:** If your combustible gas channel is calibrated to a gas other than methane, such as isobutane, use an appropriate gas cylinder to perform the calibration.

---

---

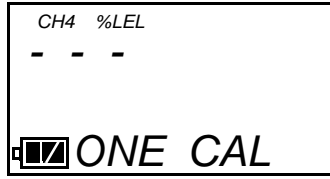
**WARNING:** *Calibrate the GX-2009 in a non-hazardous environment.*

---

1. Before performing a span adjustment, perform a fresh air adjustment as described in "Performing a Fresh Air Adjustment" on page 34.



2. At the ONE CAL screen, press and release the POWER MODE button. A channel selection screen appears that displays the CH<sub>4</sub> channel.



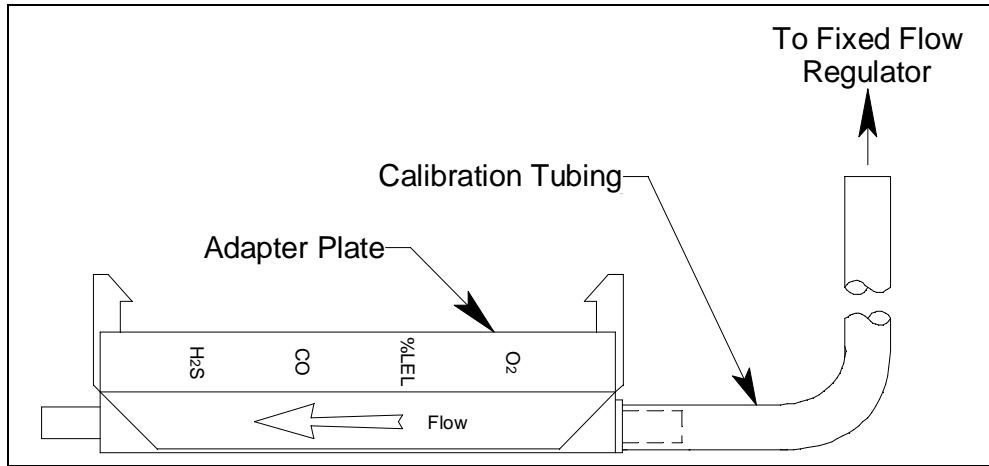
If the CH<sub>4</sub> channel is the one you want to span adjust, skip to Step 4.

If you want to span adjust a different channel, continue with Step 3.

3. Scroll through the channels using the AIR button until the channel you want to span adjust is displayed. The gas channels are displayed in the following order along with an escape option: CH<sub>4</sub>, oxygen, H<sub>2</sub>S, CO, ESCAPE.

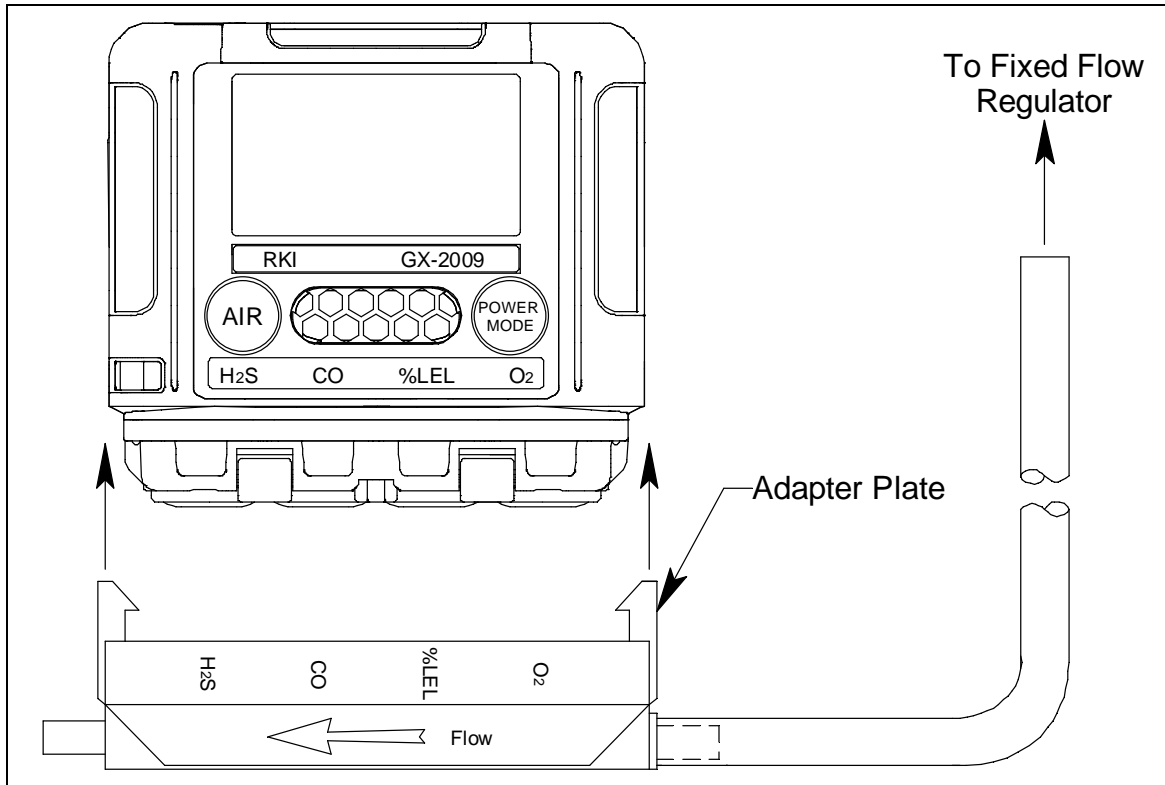
If you want to abort the span adjustment, scroll through the channels until you arrive at the screen that indicates "ESCAPE" to the right of the battery icon, then press and release the POWER MODE button to return to the ONE CAL screen.

4. Use the sample tubing to connect the calibration adapter plate to the regulator. Attach the tubing to the adapter plate on the inlet side as shown below in Figure 11.



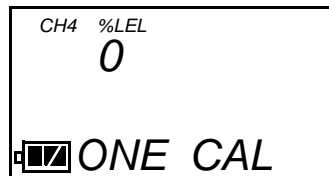
**Figure 11: Calibration Kit Assembly**

5. Push the adapter plate onto the GX-2009's sensor face. Make sure the adapter plate is oriented as shown in Figure 12 below with the sensor names on the adapter plate matching up with the sensor names on the instrument.



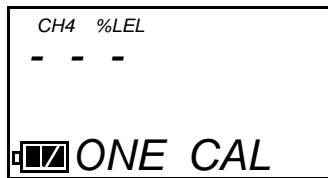
**Figure 12: Installing the Adapter Plate, One Cal**

6. Press and release the POWER MODE button, the current gas reading for the selected channel is displayed.



7. For toxic gas cylinders (like cylinders containing H<sub>2</sub>S), it is important to vent the regulator while installing it onto the cylinder. Venting the regulator during installation helps prevent air from getting into the cylinder and degrading the gas. Open the regulator by turning the knob counterclockwise and install it onto the cylinder.
8. Allow the gas to flow for two minutes.
9. Adjust the display gas reading using the AIR button to match the calibration cylinder's target gas concentration. See Step 5 on page 33 for instructions to adjust a parameter using the AIR button.
10. Press and release the POWER MODE button.

11. The GX-2009 will make the span adjustment and will return to the channel selection screen.



The channel that was just span adjusted will be displayed.

12. If you want to span adjust additional channels, repeat Step 3 through Step 11 for each channel while gas is still flowing. Make the reading adjustment right away since gas has been flowing for more than two minutes. If you need to calibrate more than two channels, use the AUTO CAL menu item to calibrate the GX-2009.
13. Turn the regulator on/off knob clockwise to close it.
14. When you are finished with span adjustments, scroll to the screen that indicates "ESCAPE."



15. Press and release the POWER MODE button to return to the ONE CAL Screen.



16. Remove the calibration adapter plate from the instrument.
17. Remove the regulator from the calibration gas cylinder.
18. Leave the regulator connected to the calibration adapter plate for convenience.
19. Store the components of the calibration kit in a safe and convenient place.

## Performing a Bump Test in BUMP

---

**NOTE:** **Bump Test Function** must be set to *On* using the GX-2009 User Setup Program in order for BUMP to appear in Calibration Mode. If **Bump Test Function** is set to *Off*, BUMP will not appear. See the GX-2009 User Setup Program Operator's Manual for instructions. The factory setting for **Bump Test Function** is *Off*.

---

Entering the BUMP menu item allows you to perform a bump test on all channels simultaneously to determine if the instrument is responding properly to gas.



Performing a bump test requires the use of a calibration kit. The procedure below describes a bump test of all four channels using a calibration kit that includes a 4-gas calibration cylinder, a 0.5 LPM (liters per minute) regulator, a calibration adapter plate, and non-absorbent sample tubing. The standard 4-gas cylinder consists of 50% LEL methane, 12% oxygen, 25 ppm H<sub>2</sub>S, 50 ppm CO, and a balance of nitrogen. If the H<sub>2</sub>S channel on your GX-2009 is active, then use a 4-gas cylinder. If the H<sub>2</sub>S channel on your GX-2009 is not active, you may use a 3-gas cylinder to perform the bump test. The standard 3-gas cylinder consists of 50% LEL methane, 12% oxygen, 50 ppm CO, and a balance of nitrogen. See "Parts List" on page 67 for available calibration kits and calibration kit spare parts.

---

**NOTE:** If your combustible gas channel is calibrated to a gas other than methane, such as isobutane, use an appropriate gas cylinder to perform the calibration.

---

---

**WARNING:** *Bump test the GX-2009 in a non-hazardous environment.*

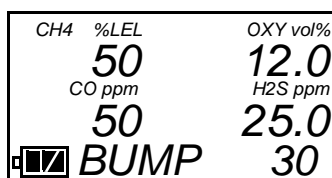
---

1. Before performing a bump test, perform a fresh air adjustment as described in "Performing a Fresh Air Adjustment" on page 34.
2. At the BUMP screen, press and release the POWER MODE button. A screen appears that displays the gas concentrations that the GX-2009 expects you to use.


---

**NOTE:** The bump test gas concentrations are the same as the AUTO CAL gas concentrations.

---

A screenshot of the instrument's display showing the BUMP screen. It displays a table of expected gas concentrations. The table has two columns and two rows of data. The first row shows CH4 %LEL as 50 and OXY vol% as 12.0. The second row shows CO ppm as 50 and H2S ppm as 25.0. Below the table, there is a small icon of a gas cylinder with a checkmark and the word "BUMP" followed by the number "30".

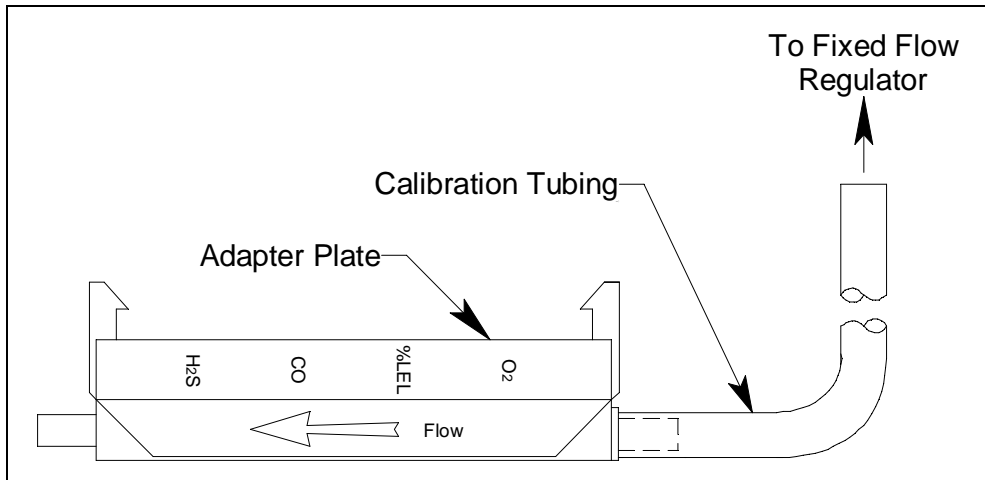
CH4 %LEL	50	OXY vol%	12.0
CO ppm	50	H2S ppm	25.0

 **BUMP** 30

If the values are not correct, you can change them by changing the AUTO CAL gas values in Calibration Mode or User Setup Mode or by using the Data Logger Management

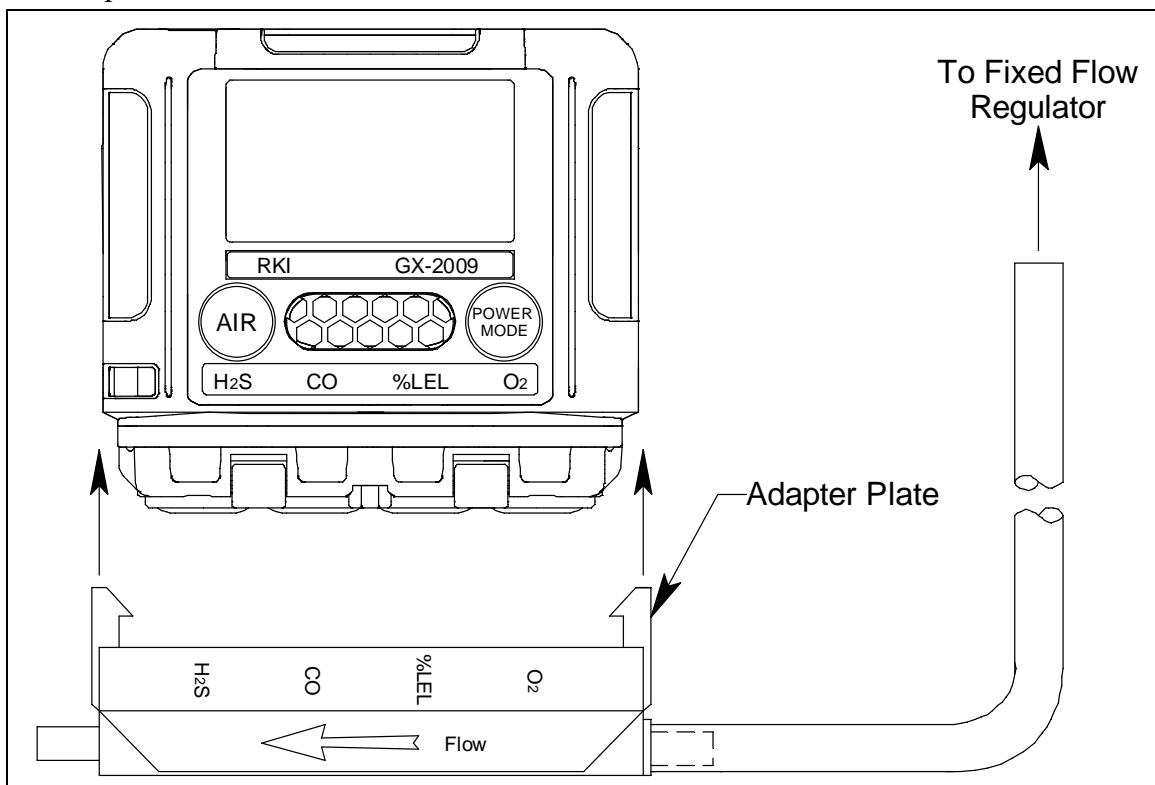
Program or the User Setup Program. To exit this screen and return to the main menu, press and release the AIR button.

3. Use the sample tubing to connect the calibration adapter plate to the regulator. Attach the tubing to the adapter plate on the inlet side as shown below in Figure 13.



**Figure 13: Calibration Kit Assembly**

4. Push the adapter plate onto the GX-2009's sensor face. Make sure the adapter plate is oriented as shown in Figure 14 below with the sensor names on the adapter plate matching up with the sensor names on the instrument.



**Figure 14: Installing the Adapter Plate**

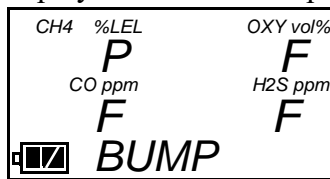
- Press and release the POWER MODE button. The LCD will display the current gas readings and the instrument will count down from 30.



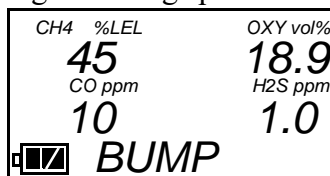
- For toxic gas cylinders (like cylinders containing H<sub>2</sub>S), it is important to vent the regulator while installing it onto the cylinder. Venting the regulator during installation helps prevent air from getting into the cylinder and degrading the gas. Open the regulator by turning the knob counterclockwise and install it onto the cylinder.

If you wish to cancel the bump test or a calibration initiated because of a failed bump test, press and hold the AIR button until you return to the BUMP screen.

- When the bump test countdown reaches 0, the unit will determine the bump test results and proceed as described in either Step 8 or Step 9 depending on the setting of **Calibration After Bump Test Failed**. See the User Setup Program Operator's Manual for a complete description of this parameter.
- When **Calibration After Bump Test Failed** is set to OFF:
  - The instrument will display which channels passed or failed the bump test.



- To view the bump test gas readings press the AIR button.



- To return to the BUMP screen in Calibration Mode, press POWER MODE. You may also press POWER MODE to return to the BUMP screen without first viewing the bump test gas readings.



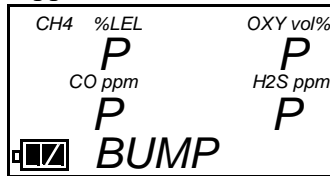
See "Troubleshooting" on page 56 to investigate the cause of the failure and replace the failed sensor or sensors if necessary.

- Turn the regulator on/off knob clockwise to close it.

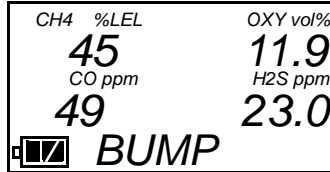
9. When **Calibration After Bump Test Failed** is set to ON:

If all channels pass the bump test,

- The following screen appears:



- To view the bump test gas readings press the AIR button.



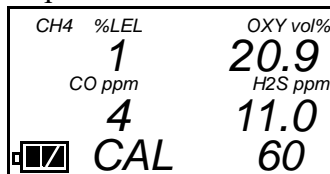
- To return to the BUMP screen in Calibration Mode, press POWER MODE. You may also press POWER MODE to return to the BUMP screen without first viewing the bump test gas readings.



- Turn the regulator on/off knob clockwise to close it.

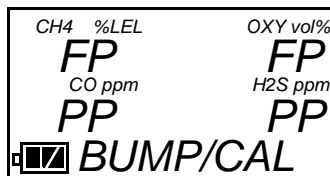
If any channel fails the bump test,

- The instrument will beep and a calibration is immediately and automatically started.

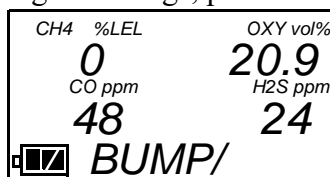


Continue to apply the calibration gas.

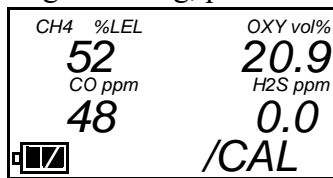
- At the end of the calibration, the instrument displays the results from both the bump test and the calibration.



- To view the bump test gas readings, press the AIR button.



- To view the calibration gas reading, press the AIR button again.



- To return to the BUMP screen in Calibration Mode, press POWER MODE at any time.



- Turn the regulator on/off knob clockwise to close it.

10. Remove the calibration adapter plate from the instrument.
11. Remove the regulator from the calibration gas cylinder.
12. Leave the regulator connected to the calibration adapter plate for convenience.
13. Store the components of the calibration kit in a safe and convenient place.

## Discharging the Batteries with the REFRESH Function

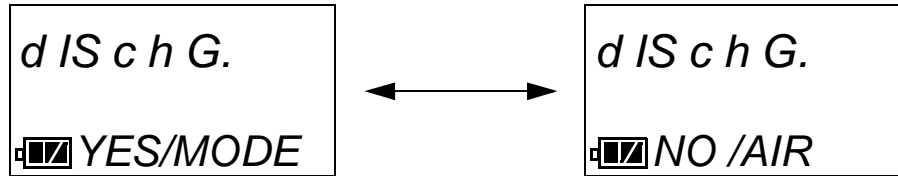
Entering the REFRESH menu item allows you to discharge the batteries.



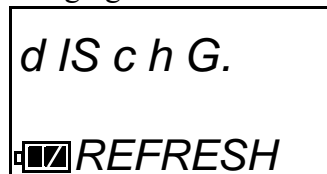
If the GX-2009's batteries are repeatedly only partially discharged before being charged or only partially charged before being discharged, the instrument's runtime may be reduced. The NiMH batteries used in the GX-2009 are resistant to this effect, but if you notice that the runtime is decreasing, run the REFRESH function two or three times and see if the runtime recovers. If the batteries are fully charged, the REFRESH function will take about three hours to discharge the batteries. If the instrument's runtime does not recover, the batteries may need to be replaced.



1. When the REFRESH screen is displayed, press and release the POWER MODE button. Two screens begin alternating prompting you to answer whether or not you want to run the REFRESH function.



2. To run the REFRESH function, press and release the POWER MODE button. The following screen will be displayed and the fill inside the battery icon will begin to flash. The GX-2009 is now discharging the batteries.



If you do not want to run the REFRESH function, press and release the AIR button. The unit will return to the REFRESH screen.

3. If you want to abort the battery discharge at any time, press and release the AIR button and the unit will return to the REFRESH screen.
4. When the unit is done discharging the batteries, the buzzer will sound a double pulsing tone, the battery icon will flash, and the following screen will appear.



5. Press and hold the POWER MODE button until the unit turns off, then release it. Recharge the GX-2009's batteries. See "Recharging the GX-2009's NiMH Batteries" on page 57.

---

## User Setup Mode

This section describes the GX-2009 in User Setup Mode. User setup mode has the same menu items as Calibration Mode with the addition of the ALARM--P menu item which allows you to set the alarm points and the PASSWORD menu item which allows you to turn the password feature on or off and set the password. The common menu items are included in User Setup Mode as a convenience to avoid turning off the unit and entering Calibration Mode if you are updating alarm points and also want to use one of the other menu items. In User Setup Mode, you can move through a menu of screens to do the following:

- Set the date and time (same as in Calibration Mode)
- Perform a fresh air adjustment (same as in Calibration Mode)
- Perform a span adjustment on all channels simultaneously (same as in Calibration Mode)
- Perform a span adjustment on one channel at a time (same as in Calibration Mode)
- Set the alarm points
- Discharge the batteries with the REFRESH function (same as in Calibration Mode)
- Turn the password feature on or off and define the password

---

**NOTE:** You can set the GX-2009 to alert you during the startup sequence when calibration or bump testing is due with the GX-2009 Setup Program. See the GX-2009 Setup Program Operator's Manual for information on setting the **Cal. Limit Display** and **Bump Limit Display** parameter.

---

The description of the menu items that are common to Calibration Mode and User Setup Mode will refer you to the appropriate pages in the Calibration Mode section.

### Using User Setup Mode

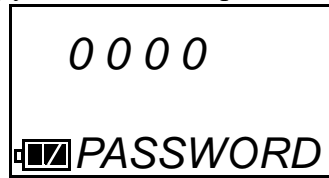
---

**WARNING:** *The GX-2009 is not in operation as a gas detector while in User Setup Mode. Although it will respond to gas in parts of AIR CAL, AUTO CAL, ONE CAL, and BUMP TEST, there are no gas alarm indications.*

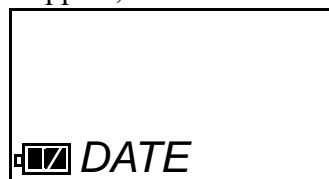
---

1. Take the GX-2009 to a non-hazardous area and turn it off if it is on.
2. Press and hold the AIR button, then press and hold the POWER MODE button. You will hear a beep after one second. Continue to hold both the AIR and the POWER MODE button.
3. After three seconds you will hear a second beep. Release both buttons when you hear the second beep.

4. If the PASSWORD menu item is set to *on*, the following screen will appear with the first digit flashing prompting you to enter the password.



- Use the AIR button to scroll through the numbers 0-9 until you arrive at the desired value, then press and release the POWER MODE button to accept the value.
- Repeat the above procedure for each digit.
- When you have set and accepted the last digit of the password, the first menu item in User Setup Mode will appear, the DATE Screen.



- If you entered the incorrect password, an error screen will appear. You must use the POWER MODE button to turn the unit off and try again if you wish to enter User Setup Mode or turn on the unit and proceed to Measuring Mode.
5. If the PASSWORD menu item is set to *off*, the first menu item in User Setup Mode displays, the DATE Screen.



6. Use the AIR button to move forward through User Setup Mode. When you get to the last menu item, the START menu item, continuing will take you to the beginning of the menu.
7. When you arrive at the item you wish to enter, press and release the POWER MODE button to enter that item.
8. When you need to adjust the numerical value of a parameter, increase it or decrease it, use the AIR button to change the value. When adjusting a numerical parameter value, it is possible to reverse the direction of adjustment. To switch from increasing to decreasing a value or decreasing to increasing a value, do the following:
- with the parameter flashing on the screen, press and hold the AIR button
  - immediately press the POWER MODE button and then release both buttons
  - the direction of adjustment when you press the AIR button is now reversed

9. When you are done using the menu items in Calibration Mode, use the AIR button to scroll through the menu items to the START item.



10. At the START screen, press and release the POWER MODE button. The GX-2009 will begin its start-up sequence.

The User Setup Mode menu items are described below in the order in which they appear while moving through User Setup Mode.

### **Setting the Date and Time**

See “Setting the Date and Time” on page 34 in the Calibration Mode section for instructions to set the date and time.

### **Performing a Fresh Air Adjustment**

See “Performing a Fresh Air Adjustment” on page 34 in the Calibration Mode section for instructions to perform a fresh air adjustment.

### **Performing a Span Adjustment in AUTO CAL**

See “Performing a Span Adjustment in AUTO CAL” on page 35 in the Calibration Mode section for instructions to perform a span adjustment in AUTO CAL.

### **Performing a Span Adjustment in ONE CAL**

See “Performing a Span Adjustment in ONE CAL” on page 40 in the Calibration Mode section for instructions to perform a span adjustment in ONE CAL.

## Setting the Alarm Points

Entering the ALARM--P menu item allows you to set the alarm points for each channel.



Table 5 below lists the factory set alarm points for each channel.

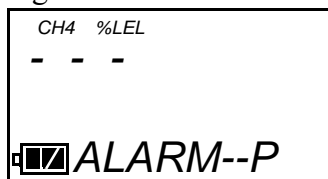
**Table 5: Factory Set Alarm Points**

Channel	Warning	Alarm	STEL	TWA
O <sub>2</sub>	19.5% Decreasing	23.5%	n/a	n/a
Combustibles	10% LEL	50% LEL	n/a	n/a
CO	25 ppm	50 ppm	200 ppm	25 ppm
H <sub>2</sub> S	5 ppm	30 ppm	5 ppm	1 ppm

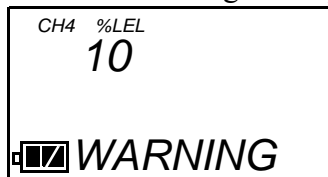
All of the alarms are increasing alarms, the alarm condition actuates when the gas level increases above the alarm point, except for the O<sub>2</sub> Warning alarm. The O<sub>2</sub> Warning alarm is a decreasing alarm. The O<sub>2</sub> Warning condition actuates when the oxygen level decreases below the alarm point.

For the combustibles channel, it is not possible to adjust either the Warning or Alarm settings to be higher than 60 %LEL. In addition, the Warning setting cannot be adjusted higher than the Alarm setting for all channels.

1. At the ALARM--P screen, press and release the POWER MODE button. The following screen will display showing the combustible channel.

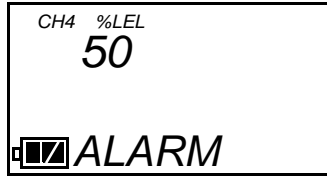


2. You can scroll through all the channels by pressing and releasing the AIR button.
3. When the desired channel is displayed, press and release the POWER MODE button to select the channel for an alarm point adjustment. In the example below, the combustibles channel has been selected and the Warning alarm point is displayed flashing.

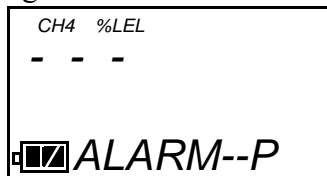


4. Use the AIR button to adjust the Warning setpoint to the desired value.

5. Press and release the POWER MODE button to save the new Warning setpoint. A screen with the Alarm setpoint flashing is displayed.



6. Use the AIR button to adjust the Alarm setpoint to the desired value.
7. Press and release the POWER MODE button to save the new Alarm setpoint. The display will return to the following screen.



---

**NOTE:** If you are setting the H<sub>2</sub>S or CO channel's alarm points, you will also see screens for setting the TWA and STEL alarms.

---

8. Repeat Step 2 through Step 7 for any other channels whose alarm points you want to change.
9. When you are done, scroll to the following screen.



10. Press and release the POWER MODE button to return to the ALARM--P screen.



## Setting the Password

You can password protect entry into the User Setup Mode with the password feature. Entering the PASSWORD menu item allows you to turn this feature on or off and enter a password if you turn it on.



The factory setting for the password feature is oFF.

1. At the PASSWORD screen, press and release the POWER MODE button. A screen will appear that shows the current password feature setting.

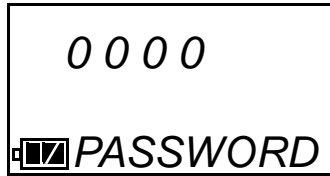


2. Press and release the air button to change the displayed setting. When the desired setting is displayed, press and release the POWER MODE button to save the setting.
3. If the password feature was set to *OFF*, the unit will exit the PASSWORD menu item and return to the PASSWORD screen.



With the password feature set to *OFF*, you will be able to enter User Setup Mode without entering a password.

4. If the password feature was set to *ON*, the following screen will appear with the first digit flashing prompting you to enter the password you want to use.



5. Use the AIR button to scroll through the numbers 0 - 9.
6. When the desired number is displayed for the first digit, press and release the POWER MODE button to save the number.
7. The next digit will begin flashing.
8. Repeat Step 5 through Step 7 until you have set all four of the digits.
9. When you save the last digit, the unit will return to the PASSWORD screen.



## Maintenance

This section describes troubleshooting procedures for the GX-2009. It also describes how to recharge the GX-2009's batteries, check the combustible sensor's condition, replace the unit's filters, sensor cover, and gas sensors.

---

**WARNING:** *RKI Instruments, Inc. recommends that service, calibration, and repair of RKI equipment be performed by personnel properly trained for this work. Replacing sensors and other parts with original equipment does not affect the intrinsic safety of the instrument.*

---

## Troubleshooting

The troubleshooting table describes error messages, symptoms, probable causes, and recommended action for problems you may encounter with the GX-2009.

**Table 6: Troubleshooting the GX-2009**

Symptoms	Probable Causes	Recommended Action
<ul style="list-style-type: none"> <li>The LCD is blank.</li> </ul>	<ul style="list-style-type: none"> <li>The unit may have been turned off.</li> <li>The batteries may need recharging.</li> </ul>	<ol style="list-style-type: none"> <li>To turn on the unit, press and hold the POWER MODE button until you hear a beep.</li> <li>If the unit does not turn on, the batteries may need to be recharged. Recharge the batteries with the charging station.</li> <li>If the difficulties continue, contact RKI Instruments, Inc. for further instruction.</li> </ol>
<ul style="list-style-type: none"> <li>The unit shows abnormally high or low readings but other gas detection instruments do not.</li> </ul>	<ul style="list-style-type: none"> <li>The GX-2009 may need to be calibrated.</li> <li>The sensor for the affected channel(s) may need replacement.</li> </ul>	<ol style="list-style-type: none"> <li>Calibrate the unit.</li> <li>Replace the sensor for the affected channel(s).</li> <li>If the difficulties continue, contact RKI Instruments for further instruction.</li> </ol>
<ul style="list-style-type: none"> <li>“FAIL” displays during span adjustment in AUTO CAL or unable to set the response readings during span adjustment in ONE CAL.</li> </ul>	<ul style="list-style-type: none"> <li>The AUTO CAL calibration gas values may not match the cylinder gas concentrations. (AUTO CAL only)</li> <li>The H<sub>2</sub>S removal filter disk over the combustible sensor or the charcoal filter disk over the CO sensor are saturated.</li> <li>The sample gas is not reaching the sensor because of a bad connection</li> <li>The calibration cylinder may be out of gas or is outdated.</li> <li>The sensor for the affected channel(s) may need replacement.</li> </ul>	<ol style="list-style-type: none"> <li>Confirm that the AUTO CAL calibration gas values match the calibration gas cylinder.</li> <li>Change H<sub>2</sub>S removal filter disk and/or the charcoal filter disk.</li> <li>Check all calibration tubing for leaks or for any bad connections.</li> <li>Verify that the calibration cylinder contains an adequate supply of fresh test sample.</li> <li>If the fail condition continues, replace the sensor(s).</li> <li>If the difficulties continue, contact RKI Instruments, Inc. for further instruction.</li> </ol>



## Recharging the GX-2009's NiMH Batteries

---

**WARNING:** *To prevent ignition of a hazardous atmosphere, batteries must only be changed or charged in an area known to be nonhazardous.*

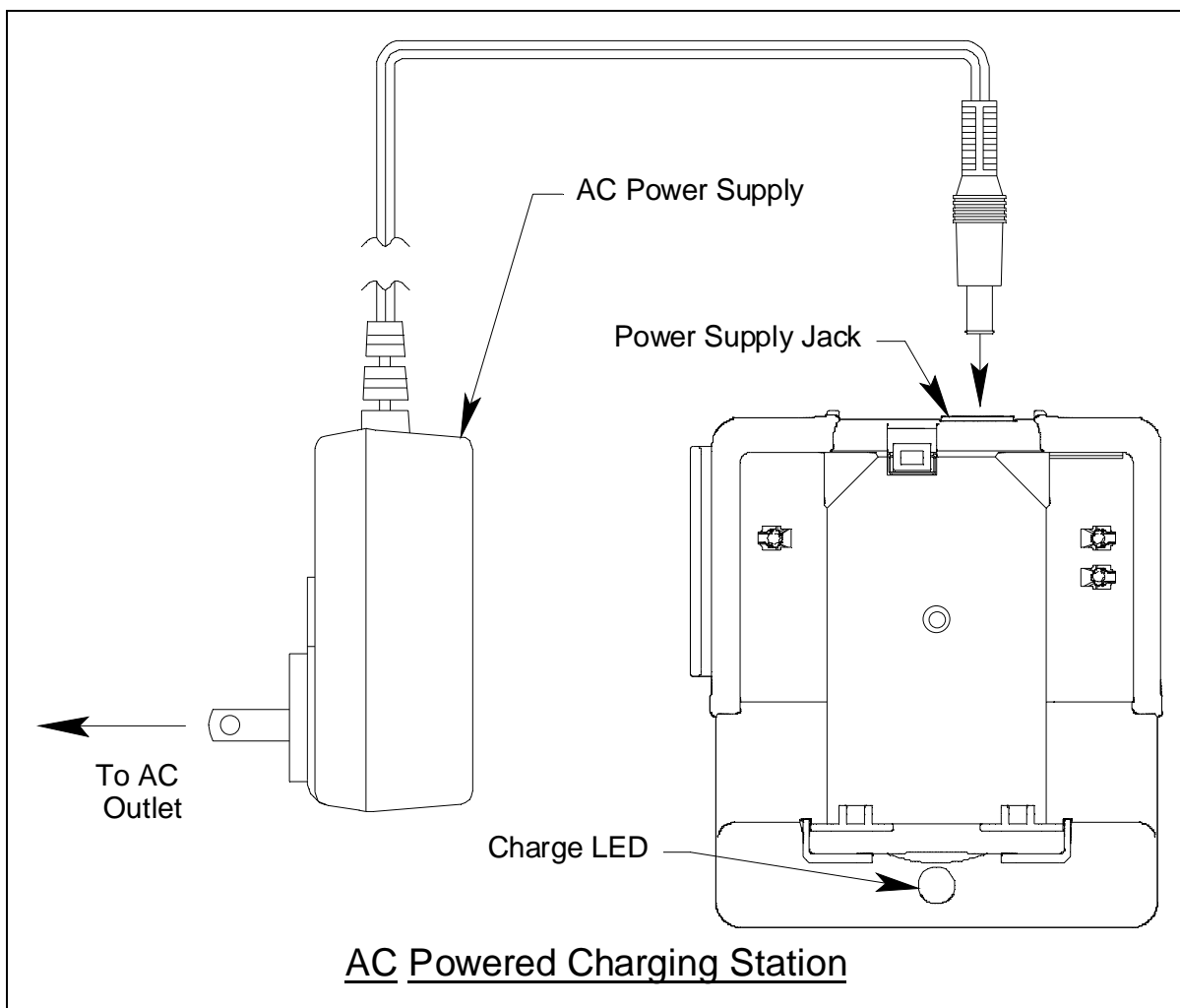
---

---

**CAUTION:** *Use with RKI NiMH battery set 49-1609RK. Charge only with RKI AC charger p/n 49-2170RK-0X (where X = 1, 2, 3, 4, or 5) or RKI DC charger 49-2171RK. Use of other rechargeable batteries or chargers or charging of other rechargeable batteries in the GX-2009 will void the warranty.*

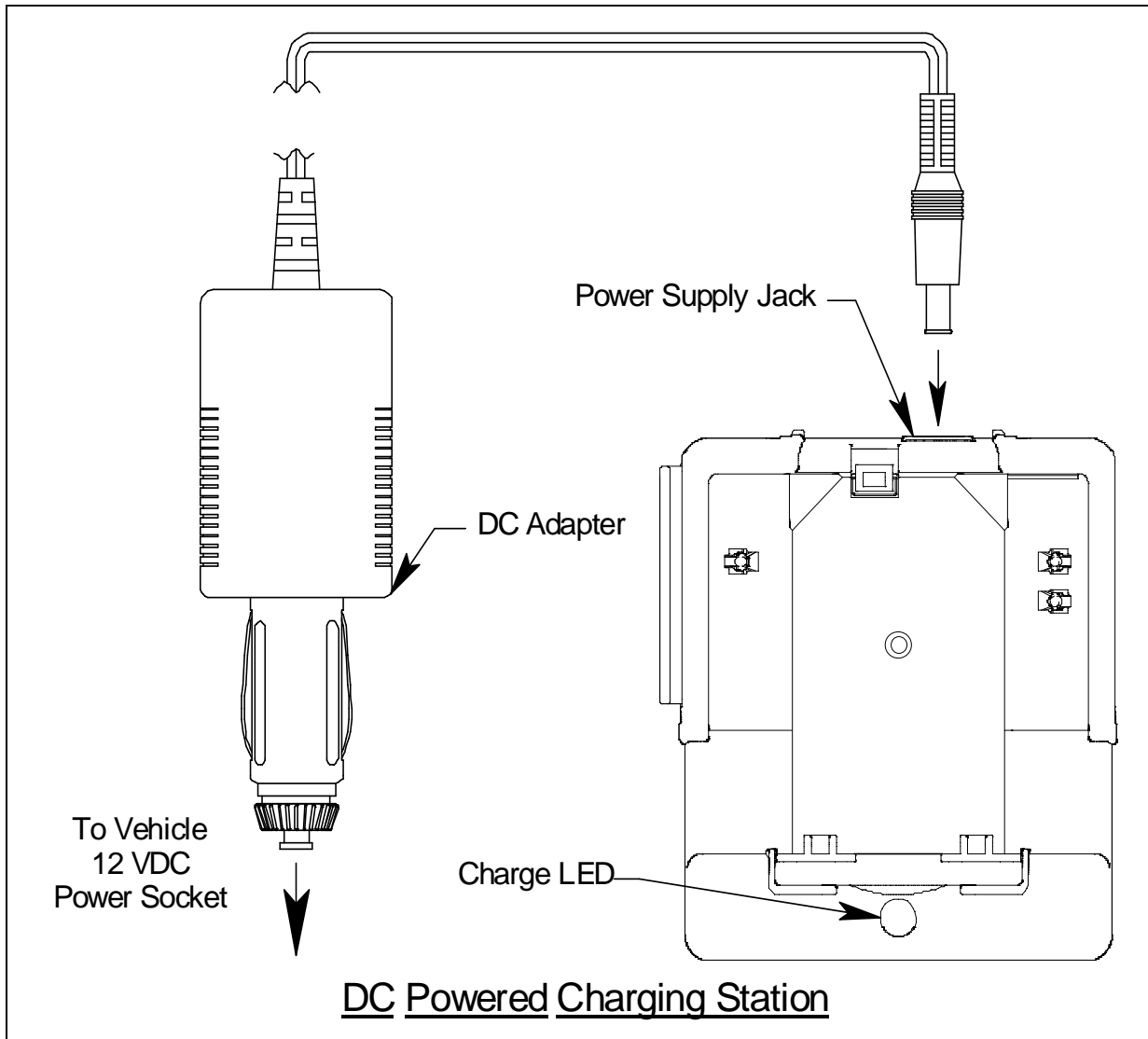
---

1. Verify that the GX-2009 is off.
2. Confirm that the adapter's DC output cord is plugged into the charger. If a multi-instrument charging station is being used, the same AC adapter is used as for the single instrument charging station.
3. If using an AC powered charging station, plug the AC adapter into an electrical outlet.



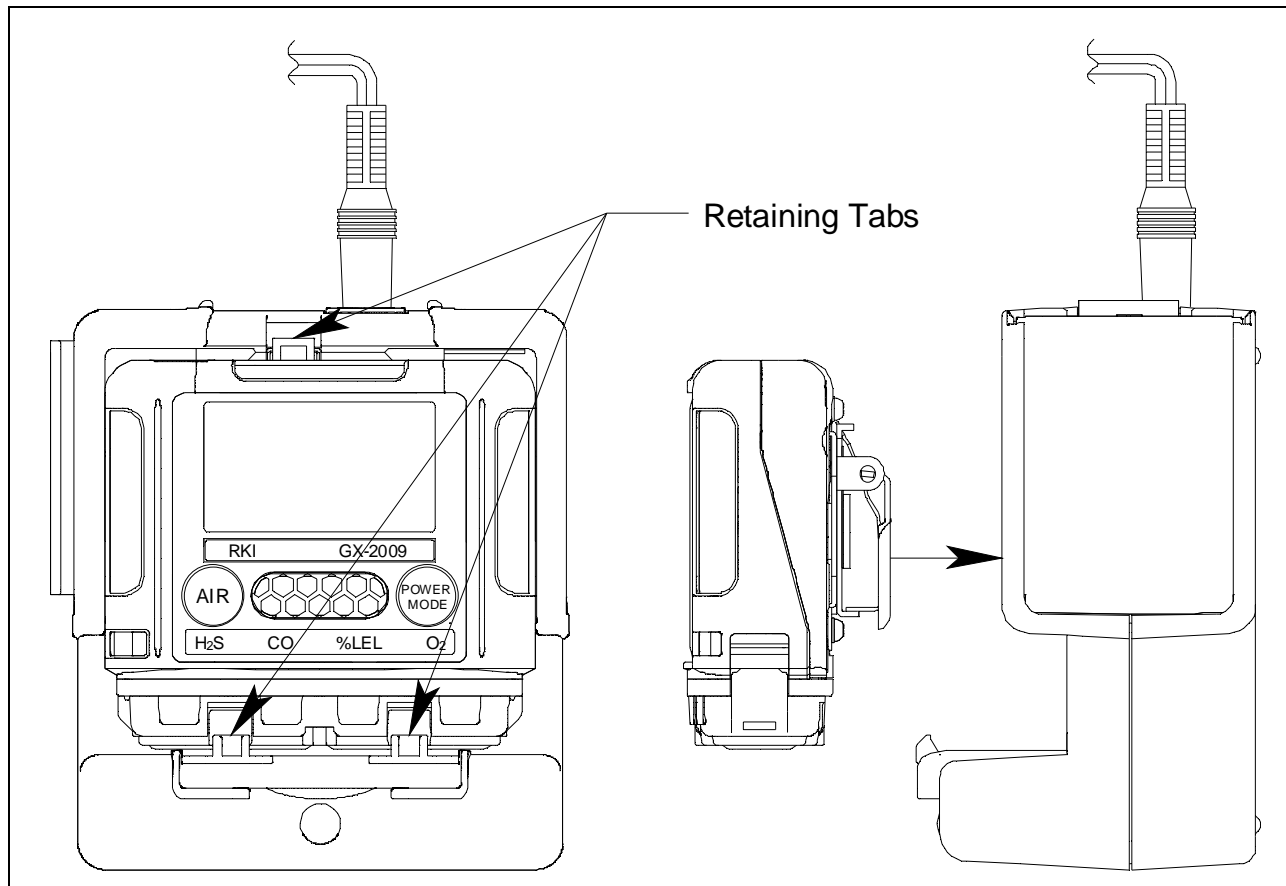
**Figure 15: Connecting the Charging Station's AC Adapter**

If using a DC powered charging station, plug the 12 VDC vehicle plug adapter into a vehicle's 12 VDC power socket.




**Figure 16: Connecting the Charging Station's DC Adapter**

- Put the GX-2009 in the charging base. Tabs at the top and bottom of the charging base retain the instrument.



**Figure 17: Putting the GX-2009 in the Charging Base**

- While the unit is being charged, the red charging LED on the top face of the charger is on.
- When the charging LED turns off, the GX-2009's batteries are fully charged. It takes approximately 3 hours to recharge a fully discharged battery set.
- To verify whether the batteries are fully recharged, remove the unit from the charging base, then press the POWER MODE button to start up the unit. If the battery icon on the LCD is fully colored in, then the unit has been completely recharged. 

---

**NOTE:** A battery set will have a typical service life of 500 charging cycles.

---

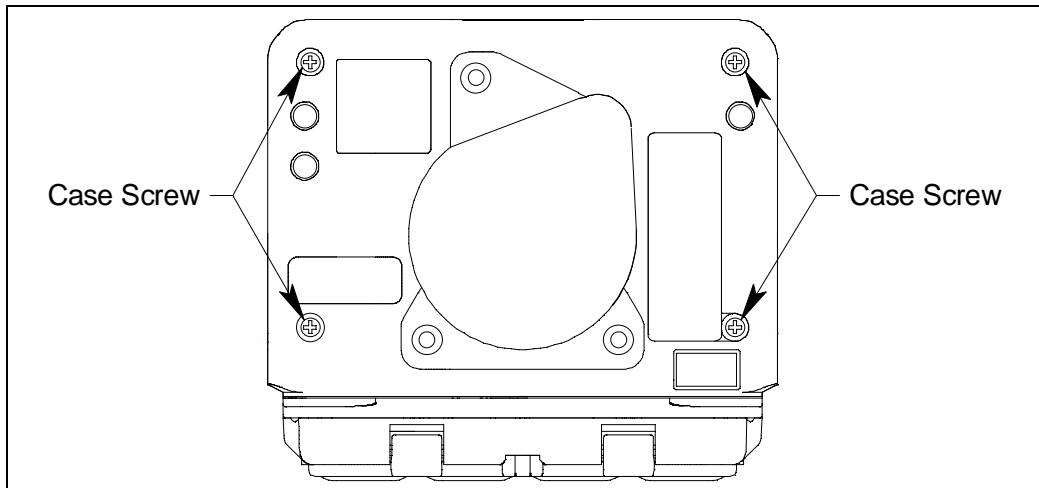
When using the GX-2009, draining the batteries as much as possible before recharging them will help maintain the maximum operating time. If the batteries are regularly only partially drained before charging or partially charged before using the instrument, the battery may experience a “memory effect” and the run time of the instrument may be decreased. If you notice this effect with your instrument, use the REFRESH function described in “Discharging the Batteries with the REFRESH Function” on page 48 to discharge your batteries before recharging them.

## Replacing the GX-2009's NiMH Batteries

**WARNING:** *Replace the batteries in a non-hazardous environment.*

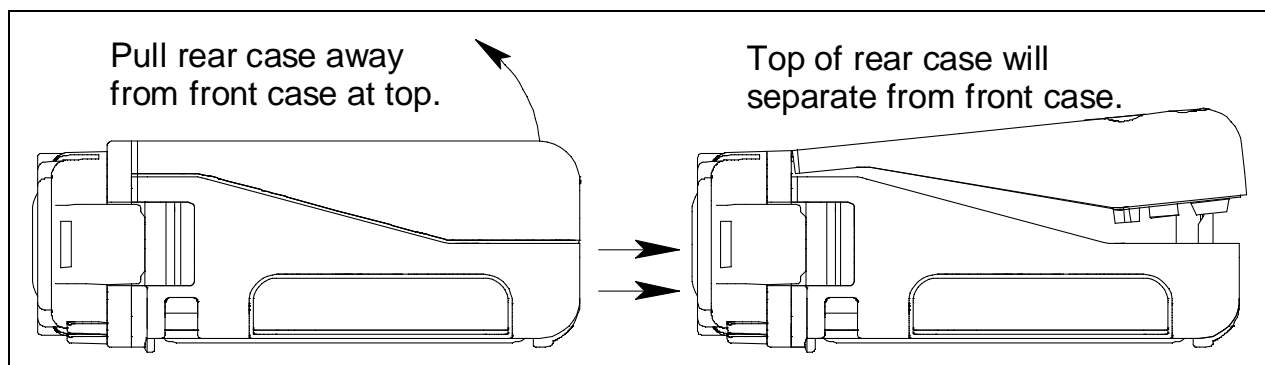
Replace the battery set when it no longer holds a charge.

1. Verify that the GX-2009 is off.
2. Use a small phillips head screwdriver to remove the four screws that hold the two halves of the case together. They are accessible from the back of the instrument.



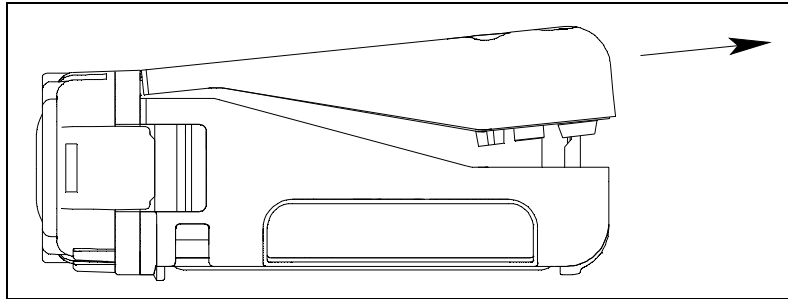
**Figure 18: Removing the Case Screws**

3. Grasp the instrument by the front case with your left hand.
4. Grasp the rear case near the top where it is deepest with your right hand and gently pull the top of the rear case slightly away from the top of the front case, rotating it about the bottom of the rear case.



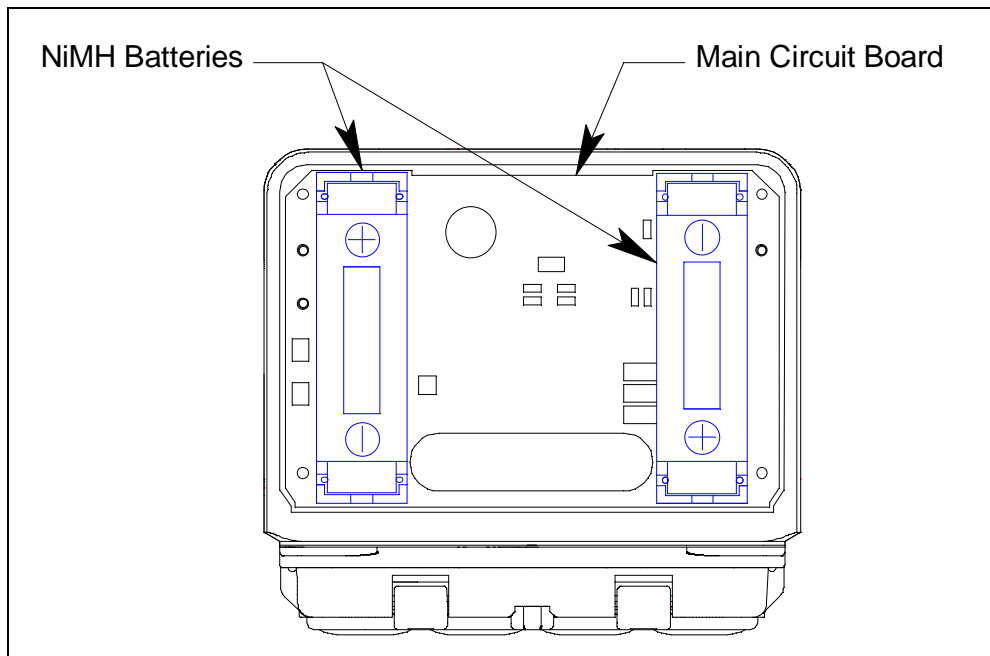
**Figure 19: Opening the Case**

5. As you pull the top of the rear case away from the front case, you will feel a slight click as the bottom of the rear case separates from the bottom of the front case. Pull the rear case away from the front case. Keep the instrument flat and steady so that the batteries do not drop out of the case.



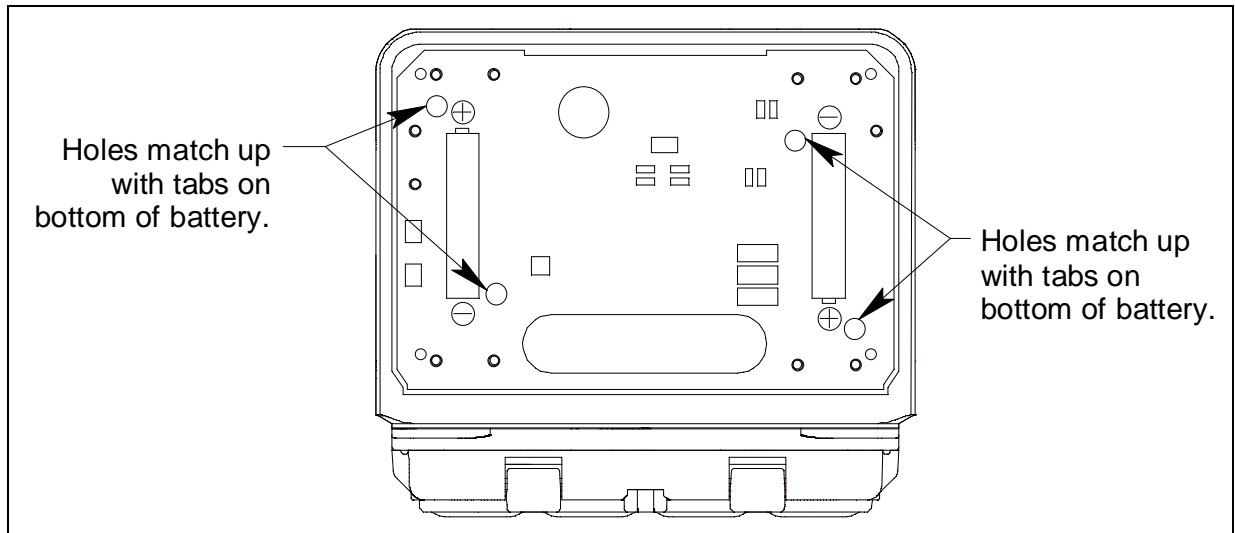
**Figure 20: Removing the Rear Case**

6. The batteries will be visible in the front case on the main circuit board. Once the front case is removed, they are no longer held in place and can be easily removed.



**Figure 21: NiMH Batteries**

7. Remove each battery by gently pulling it away from the circuit board. Each battery has an integral holder that provides electrical connection to the circuit board.



**Figure 22: Front Case With Batteries Removed**

8. Replace each battery with a new one. Note the polarity markings on the circuit board and batteries when installing each battery. Tabs on the bottom of each battery match up with holes in the circuit board.
9. Reinstall the rear case to the front case with the four case screws.

### **Checking the Combustible Gas Sensor's Condition**

If you suspect that the combustible sensor has been contaminated or may be reaching the end of its operational life, do the following to confirm it is still operating properly:

1. Perform a fresh air adjustment as described in "Performing a Fresh Air Adjustment" on page 34.
2. Apply calibration gas as described in "Performing a Span Adjustment in ONE CAL" on page 40.
3. Instead of setting the gas reading to match the calibration gas concentration, adjust the gas reading as high as possible.
4. A new sensor can typically be adjust to more than twice the calibration gas concentration. If you are not able to adjust the combustible gas reading to be at least 10% higher than the calibration gas concentration, then the sensor should be replaced as soon as possible.

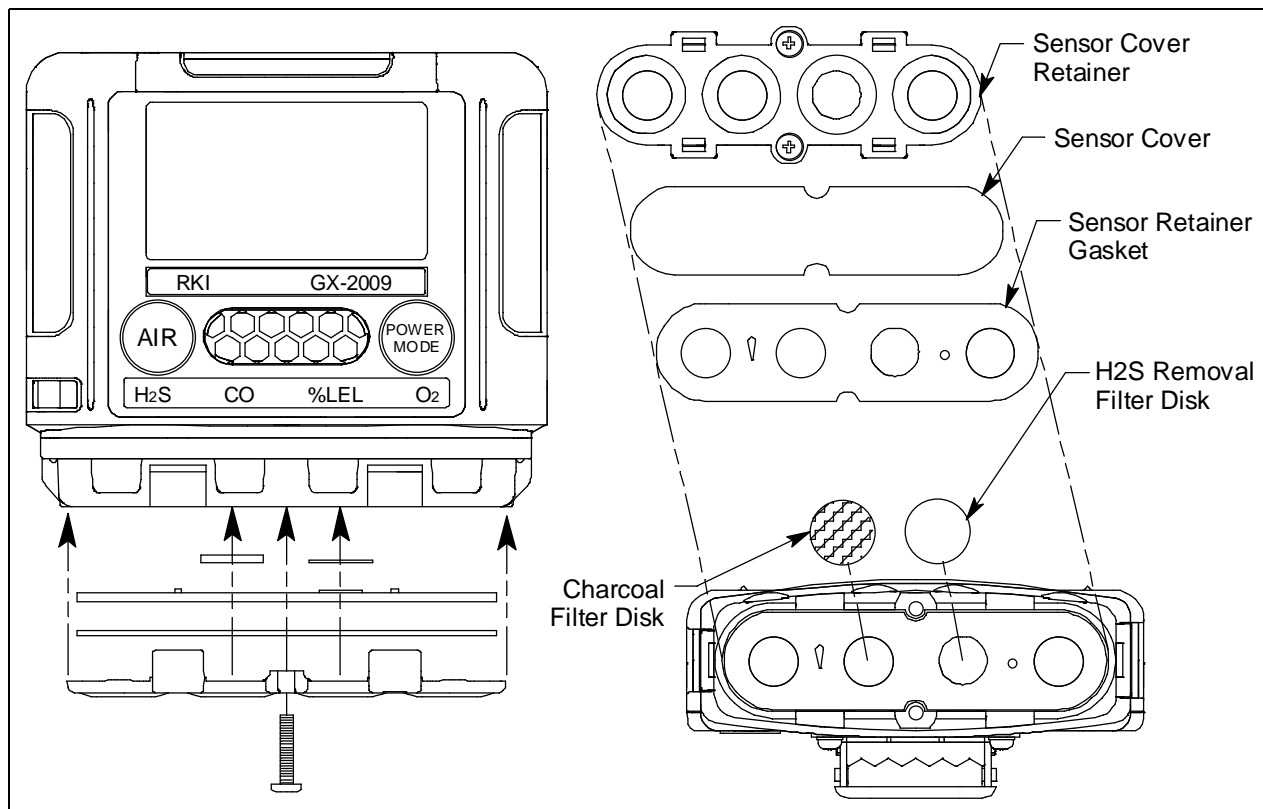
## Replacing the Scrubber Filters

The H<sub>2</sub>S filter disk is dark red in color and although it may darken over time, its color is not indicative of remaining filter life. The H<sub>2</sub>S filter disk can absorb H<sub>2</sub>S for 33 ppm hours and should be replaced after that much exposure. With this many ppm hours of absorption, the H<sub>2</sub>S filter disk should be replaced after 80 minutes of exposure to 25 ppm H<sub>2</sub>S. This equates to replacing the H<sub>2</sub>S filter disk after 40 2-minute calibrations with a cylinder containing 25 ppm H<sub>2</sub>S. If H<sub>2</sub>S exists in the monitoring environment, the H<sub>2</sub>S filter disk will have to be replaced more frequently.

---

**WARNING:** *Replace the scrubber filters in a non-hazardous environment.*

---



**Figure 23: Removing the Sensor Retainer and Replacing the Scrubber Filters**

1. Verify that the GX-2009 is off.
2. Unscrew the two screws that secure the sensor retainer and sensor cover retainer to the GX-2009 and remove them.
3. Using a small flat blade screwdriver, gently pry each side of the sensor cover retainer away from the sensor retainer.
4. Remove the sensor cover and sensor retainer gasket to gain access to the scrubbers.
5. The charcoal filter disk is located in the CO sensor diffusion port. One filter disk is used. One H<sub>2</sub>S removal filter disk is located in the combustible gas diffusion port.

6. When the appropriate scrubber filters have been replaced, reinstall the sensor retainer gasket and sensor cover.
7. Reattach the sensor cover retainer in its original position. It should snap into place onto the sensor retainer.
8. Replace the two screws that you removed in Step 2 above to secure the sensor retainer and sensor cover retainer to the GX-2009.

## Replacing the Sensor Cover

---

***WARNING: Replace the sensor cover in a non-hazardous environment.***

---

1. Verify that the GX-2009 is off.
2. Unscrew the two screws that secure the sensor retainer and sensor cover retainer to the GX-2009 and remove them.
3. Using a small flat blade screwdriver, gently pry each side of the sensor cover retainer away from the sensor retainer.
4. Remove the sensor cover then insert the replacement cover.
5. Reattach the sensor cover retainer in its original position. It should snap into place onto the sensor retainer.
6. Replace the two screws that you removed in Step 2 above to secure the sensor retainer and sensor cover retainer to the GX-2009.

## Replacing a Sensor

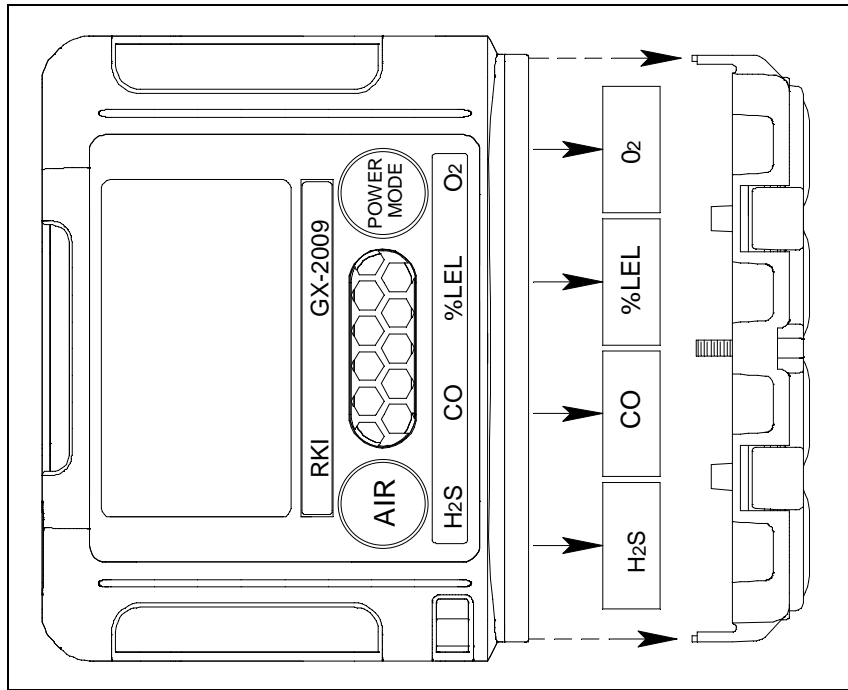
---

***WARNING: Replace the sensors in a non-hazardous environment.***

---

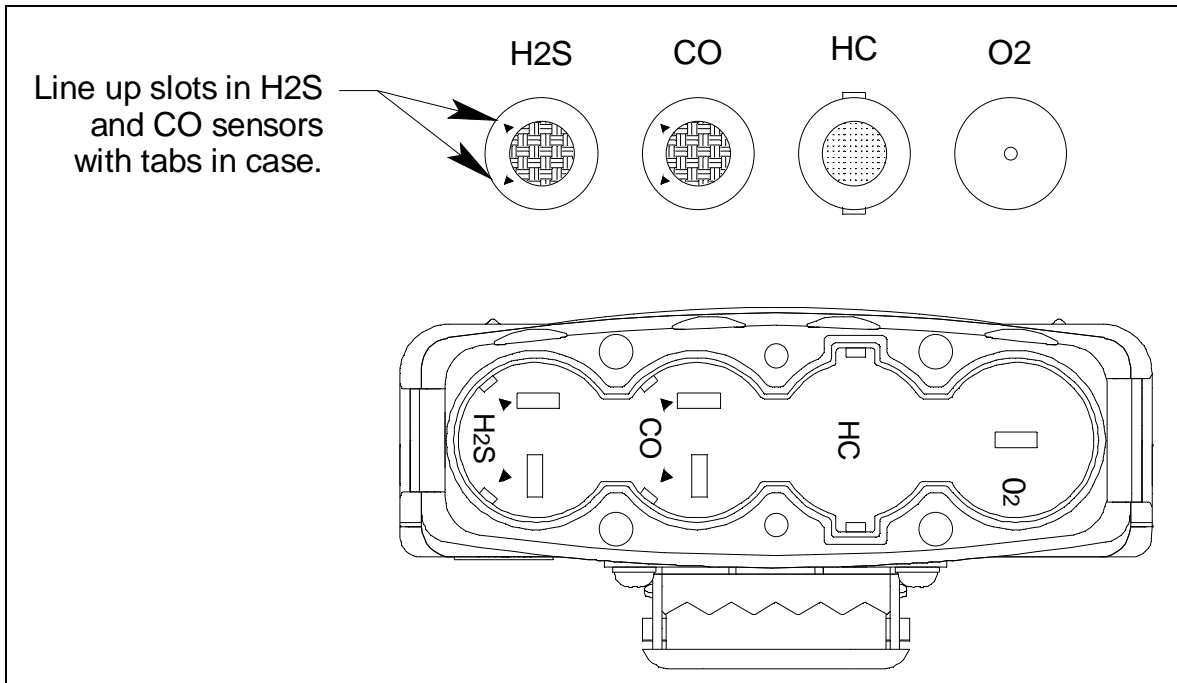
1. Verify that the GX-2009 is off.
2. Unscrew the two screws that secure the sensor retainer and the sensor cover retainer to the GX-2009 and remove them.
3. Use a small flat blade screwdriver to pry each end the sensor retainer from the case with the sensor cover retainer still attached.





**Figure 24: Removing the Sensor Retainer to Replace a Sensor**

4. Remove the sensor from its socket.
5. Carefully insert the replacement sensor in the socket.



**Figure 25: Replacing the Sensors and Their Locations in the GX-2009**

---

**CAUTION:** *When replacing a sensor, verify that the sensor is properly aligned with its socket before inserting it into the socket. The CO and H<sub>2</sub>S sensors have alignment slots which match up with alignment tabs in the sockets. The combustible gas sensor has two non-polarized contacts which must line up with the contacts in the socket. Forcing a sensor into its socket may damage the sensor or the socket.*

---

6. Snap the sensor retainer back onto the case, then secure it to the GX-2009 with the two screws. The sensor retainer's tabs that snap onto the case are keyed so you can only snap it to the case one way.
7. Calibrate the new sensor as described in "Performing a Span Adjustment in AUTO CAL" on page 35 or "Performing a Span Adjustment in ONE CAL" on page 40.

## Parts List

Table 7 lists replacement parts and accessories for the GX-2009.

**Table 7: Parts List**

Part Number	Description
06-1248RK-03	Calibration kit tubing, 3 foot length
07-6021RK	Sensor retainer gasket
10-1098RK	Screw with washers, for alligator or belt clip installation
10-1104RK	Screw, M2 x 10 mm, for case or sensor retainer
13-0112RK	Wrist strap
13-0117RK	Belt clip
13-0119	Alligator clip
21-1882RK	Sensor retainer
21-1884RK	Sensor cover retainer
33-0172RK	Sensor cover, water proof
33-7102RK	Charcoal filter disk, 5 pack, for CO diffusion port
33-7114RK	Filter disk, H <sub>2</sub> S scrubber, 5 pack, for combustible diffusion port
45-2430RK	Plug adapter for AC adapter, US to Euro, non grounded
47-5084RK	USB/IrDA adapter module, Legasic, for use with all premier portables (without USB cable)
47-5084RK-01	USB/IrDA adapter assembly, Legasic, for use with all premier portables (with module and USB cable)
47-5085RK	Cable, USB A to USB mini, 6 feet, for USB/IrDA adapter module
47-5093	USB/IrDA adapter with cable and CD (not for use with Eagle 2)
49-1609RK	Set of 2 Ni-MH batteries
49-0115RK	AC adapter for charging station
49-2020RK	DC adapter for charging station
49-2170RK-01	Charging station with AC adapter for single instrument, 115 VAC
49-2170RK-02	Charging station with AC adapter for two instruments, 115 VAC
49-2170RK-03	Charging station with AC adapter for three instruments, 115 VAC
49-2170RK-04	Charging station with AC adapter for four instruments, 115 VAC
49-2170RK-05	Charging station with AC adapter for five instruments, 115 VAC
49-2171RK	Charging station with 12 VDC vehicle plug adapter

**Table 7: Parts List**

<b>Part Number</b>	<b>Description</b>
71-0158RK	GX-2009 Portable Gas Monitor Operator's Manual
71-0162RK	GX-2009 User Setup Program Operator's Manual
71-8002RK	GX-2009 Product CD, includes Data Management Program, User Setup Program, and all operator's manuals
81-GX01HSCO	58 liter four-gas cylinder, regulator, calibration plate, case & tubing
81-GX01HSCO-LV	34 liter aluminum four-gas cylinder, regulator, calibration plate, case & tubing
81-GX01CO	103 liter three-gas cylinder, regulator, calibration plate, case & tubing
81-GX01CO-LV	34 liter steel three-gas cylinder, regulator, calibration plate, case & tubing
81-0090RK-01	Three-gas calibration cylinder, 50% LEL CH <sub>4</sub> /12% O <sub>2</sub> /50 ppm CO, 34 liter steel
81-0090RK-03	Three-gas calibration cylinder, 50% LEL CH <sub>4</sub> /12% O <sub>2</sub> /50 ppm CO, 103 liter
81-0154RK-02	Four-gas calibration cylinder, 50% LEL CH <sub>4</sub> /12% O <sub>2</sub> /50 ppm CO/25 ppm H <sub>2</sub> S, 58 liter
81-0154RK-04	Four-gas calibration cylinder, 50% LEL CH <sub>4</sub> /12% O <sub>2</sub> /50 ppm CO/25 ppm H <sub>2</sub> S, 34 liter aluminum
81-1050RK	Regulator, fixed flow, 0.5 LPM, with gauge and knob, for 17 liter and 34 liter steel cylinders (cylinders with external threads)
81-1051RK	Regulator, fixed flow, 0.5 LPM, with gauge and knob, for 34 liter aluminum, 58 liter, and 103 liter cylinders (cylinders with internal threads)
81-1107RK	Calibration/sample cap, rubber
81-1160RK	Hand aspirated sampler, w/10' hose, probe
ES-1821	Carbon monoxide sensor
ES-1827i	Hydrogen sulfide sensor
NC-6264A	Combustibles sensor
OS-BM2	Oxygen sensor